

Monocarrier™ Toughcarrier™

NSK single-axis actuator can be used in wide range of applications, from lightweight transport to high-load. Significantly saves designing load of machinery through an integration of linear motion components in one unit, the compact size by integrated structure



Monocarrier™
Toughcarrier™

1 Monocarrier™

1-1. Features	5
1-2. Classification and Series	7
1-3. Accessories	9
1-4. Selection of Monocarrier	10
1-4.1. Procedures for Selecting Monocarrier ...	10
1-4.2. Rigidity	10
1-4.3. Maximum Speed	11
1-4.4. Accuracy Grade	13
1-4.5. Stroke and Ball Screw Lead ...	13
1-4.6. Basic Load Rating	15
1-4.7. Estimation of Life Expectancy ...	17
1-4.8. Example of Life Estimation ...	19
1-5. MCM Series	23
1-5.1. MCM Series Reference Number Coding ...	25
1-5.2. MCM Series Dimension Table of Standard Products	26
1-5.3. MCM Series Accessories ...	47
1-6. MCH Series	71
1-6.1 MCH Series Reference Number Coding ...	73
1-6.2 MCH Series Dimension Table of Standard Products	74
1-6.3 MCH Series Accessories ..	81

2 Toughcarrier™

2-1. Features	93
2-2. Classification and Series	93
2-3. Accessories	95
2-4. Selection of Toughcarrier	96
2-4.1 Selection Procedures	96
2-4.2 Stroke and Lead	97
2-4.3 Reference Number Coding and Accuracy Grade	98
2-4.4 Maximum Speed	99
2-4.5 Rigidity	101
2-4.6 Basic Load Rating	102
2-4.7 Estimation of Life Expectancy ...	103
2-4.8 Example of Life Estimation ...	105
2-5. TCH Series Dimension Table of Standard Products	109
2-5.1 TCH06 Series	109
2-5.2 TCH09 Series	111
2-5.3 TCH10 Series	113
2-6. Accessories	115
2-6.1 Sensor Unit	115
2-6.2 Cover Unit	116
2-6.3 Motor Bracket	119
2-7. Motor Bracket Compatibility Table ...	128
2-8. Sensor Rail and Top Cover Unit Combination Table	129
2-9. Toughcarrier High-Thrust Series ...	132

3 Technical Materials

3-1. Sensor Specification	135
3-1.1 Proximity Switch	135
3-1.2 Photo Sensor	136
3-2. Characteristics and Evaluation Method	137
3-2.1 Positioning Accuracy	137
3-2.2 Repeatability	137
3-2.3 Running Parallelism	137
3-3. Special Specifications	138
3-4. Maintenance	139
3-4.1 Maintenance Method	139
3-4.2 NSK K1™ Lubricant Unit ...	139
3-5. NSK Clean Grease LG2 Specification ...	140

Monocarrier™, Toughcarrier™

All-in-one structure (ball screw, linear guide and base integrated) results in a light and compact actuator without extra work for design or adjustment when installing. Design and assembly loads can be reduced by unit type. Also, the many variations make it possible to deal with many different uses.

Monocarrier™ and Toughcarrier™ Classifications

● Monocarrier™

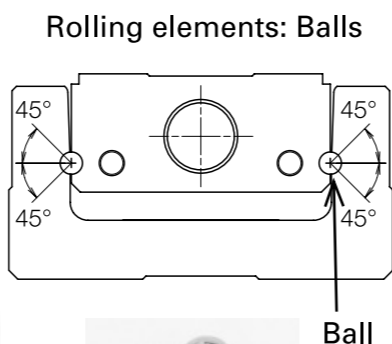
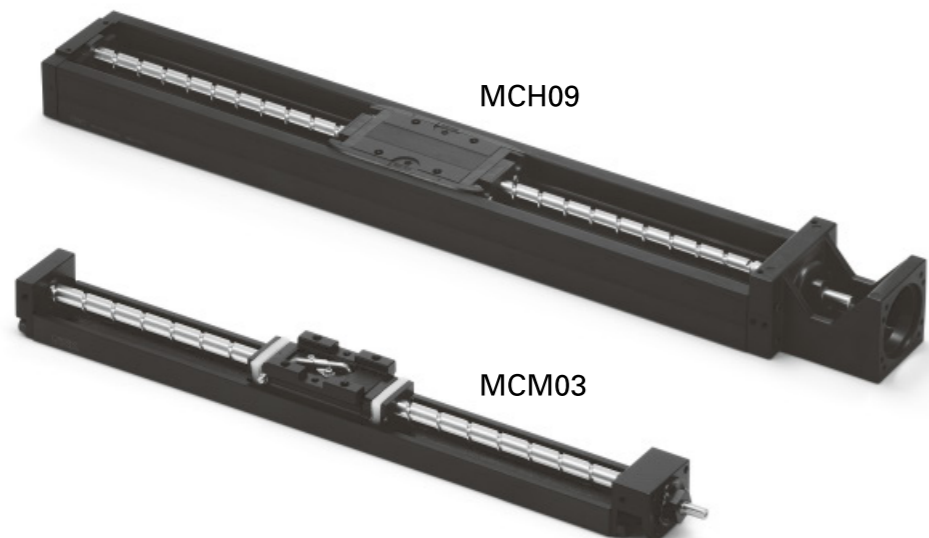

● Toughcarrier™: High load capacity

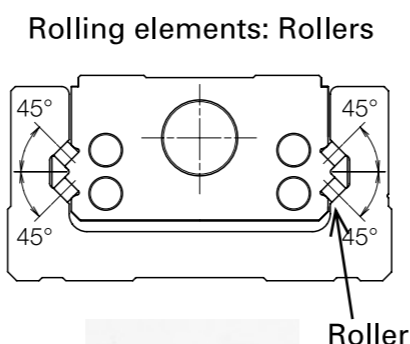
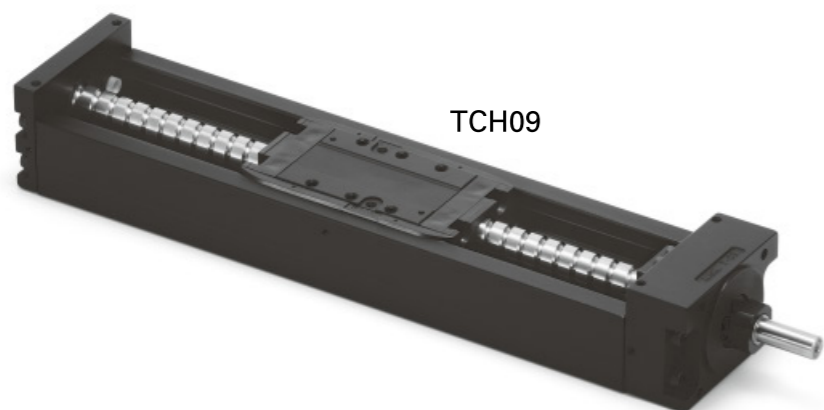

Procedure for Selecting Monocarrier™ and Toughcarrier™ models

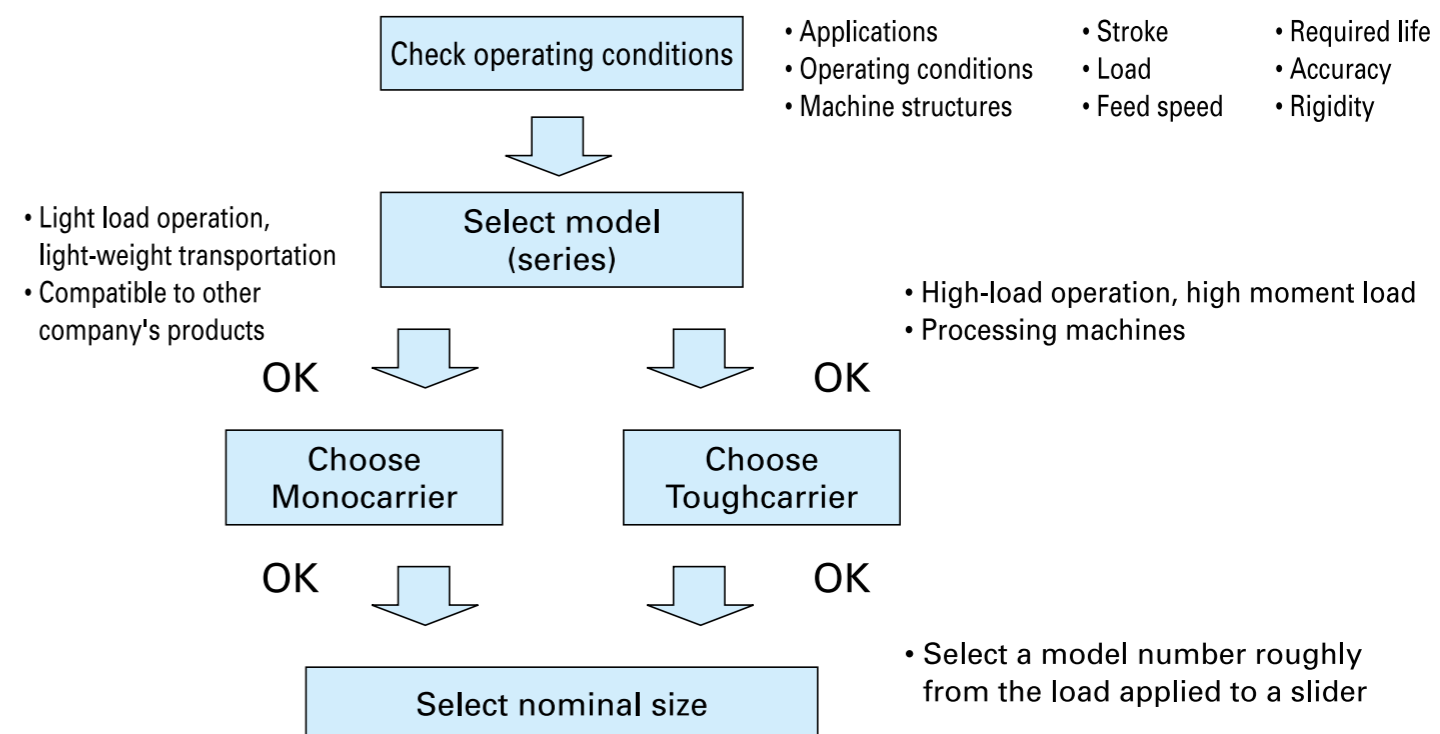

Monocarrier™ and Toughcarrier™ Composition

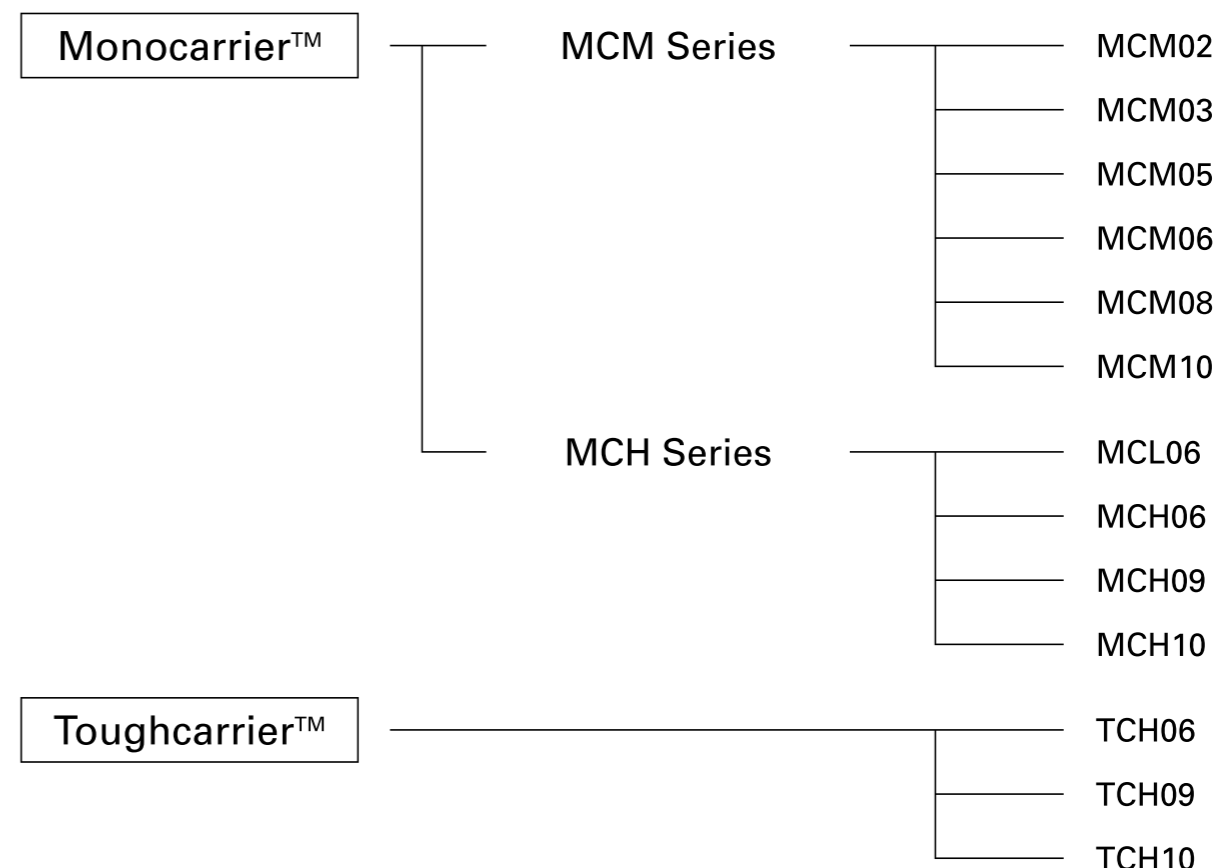

1 Monocarrier™

1-1 Features	5
1-2 Classification and Series	7
1-3 Accessories	9
1-4 Selection of Monocarrier	10
1-4.1 Procedures for Selecting Monocarrier	10
1-4.2 Rigidity	10
1-4.3 Maximum Speed	11
1-4.4 Accuracy Grade	13
1-4.5 Stroke and Ball Screw Lead	13
1-4.6 Basic Load Rating	15
1-4.7 Estimation of Life Expectancy	17
1-4.8 Example of Life Estimation	19
1-5 MCM Series	23
1-5.1 MCM Series Reference Number Coding	25
1-5.2 MCM Series Dimension Table of Standard Products	26
1-5.3 MCM Series Accessories	47
1-6 MCH Series	71
1-6.1 MCH Series Reference Number Coding	73
1-6.2 MCH Series Dimension Table of Standard Products	74
1-6.3 MCH Series Accessories	81

1 Monocarrier™

1-1 Features

NSK's Monocarrier is the culmination of technology and innovation in linear motion. This lightweight, compact single axis linear actuator integrates quality NSK ball screw, linear guide and support bearings into one unit.

1 Light weight, compact design

- Available in two different shapes of cross-section, depending on application.
Light weight type: MCM Series
Rigid type: MCH Series

2 All -in-one structure

- The all-in-one structure integrates a ball screw, a linear guide and support bearings into a single unit to significantly reduce design and installation time.
- Multiple datum planes, the bottom and a lateral side of the rail, facilitate highly accurate installation.
- Immediate operation after installation and run-in is possible.
- A wide selection of fine to high helix leads are available.

4 Long term maintenance free

- Use of NSK K1 Lubrication Units and grease maintains a smooth lubricating performance for long periods in mechanical environments where lubrication is difficult to apply, where use of oil is not permitted because of hygienic issues, or where the mechanical equipment is subjected to frequent wash downs.
- NSK K1 lubrication unit is available for food processing machines and medical equipment.
- Grease for clean environments and for general machinery is available.

3 Superb antirust capability

- Low temperature chrome plating is a standard feature for the bodies and sliders to control rusting in normal operating and storing environments. Fluoride low temperature chrome plating is optionally available for much higher rust prevention.

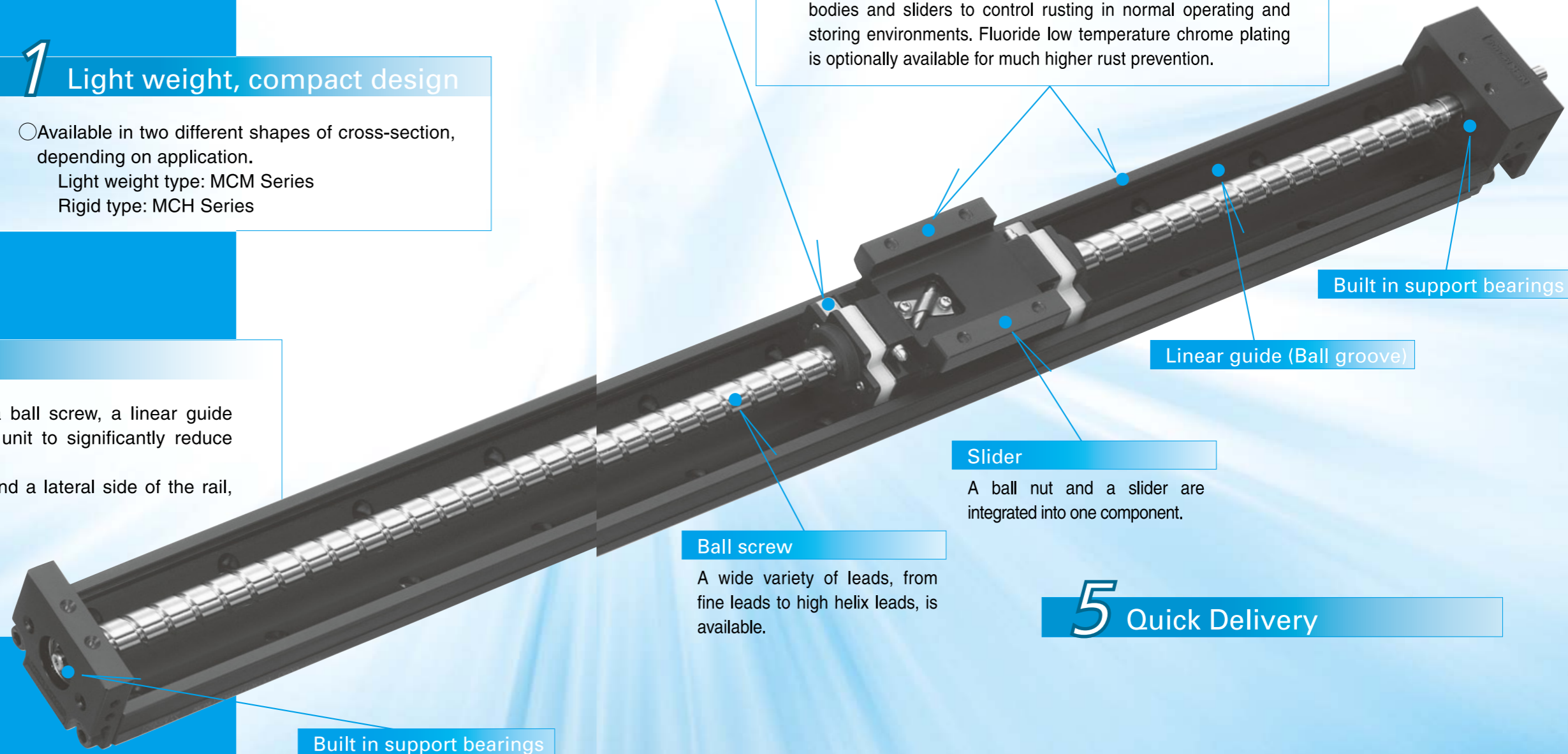

Slider

A ball nut and a slider are integrated into one component.

Ball screw

A wide variety of leads, from fine leads to high helix leads, is available.

Linear guide (Ball groove)

Built in support bearings

Built in support bearings

5 Quick Delivery

M O N O C A R R I E R™

1-2 Classification and Series

Table 2.1

	Light Weight	Beam Rigidity	Moment Rigidity
MCM Series	◎	○	○
MCH Series	○	◎	○

◎: Excellent ○: Suitable in use

[MCM Series Cross-sections]

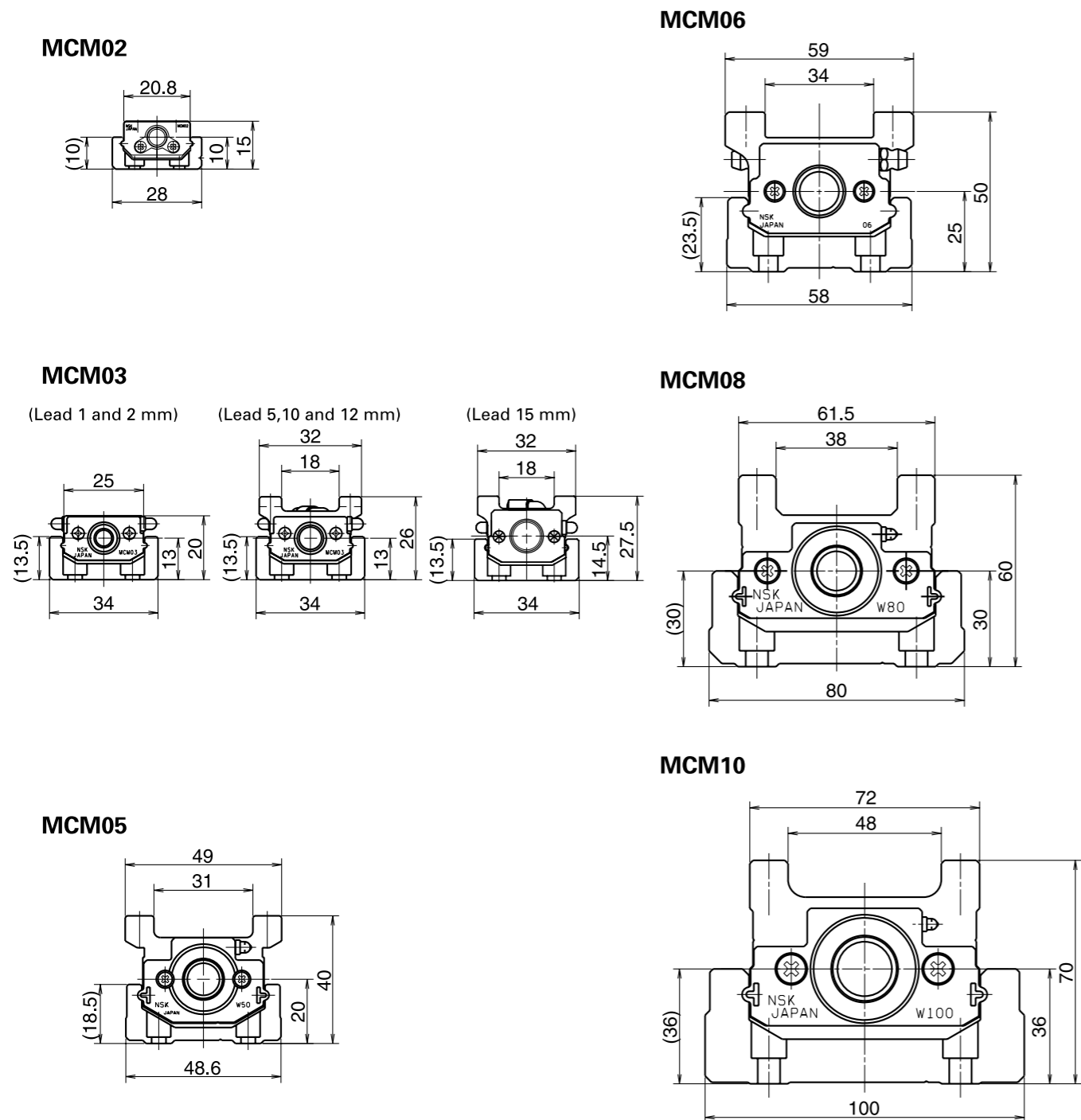

Fig. 2.1

Accuracy	Long Stroke	Size Variation
◎	○	◎
◎	◎	○

[MCH Series Cross-sections]

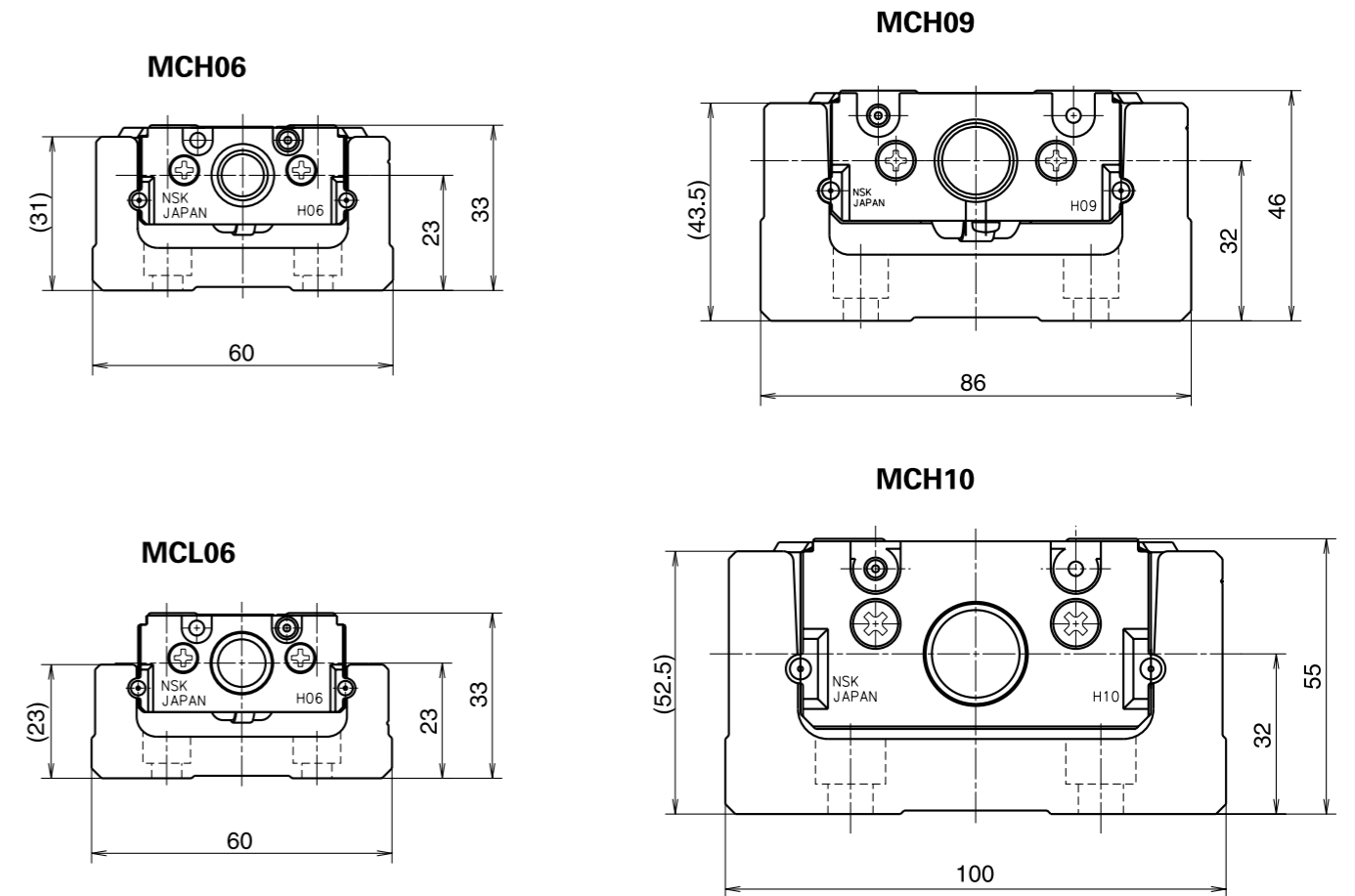

Fig. 2.2

1-3 Accessories

MCM Series

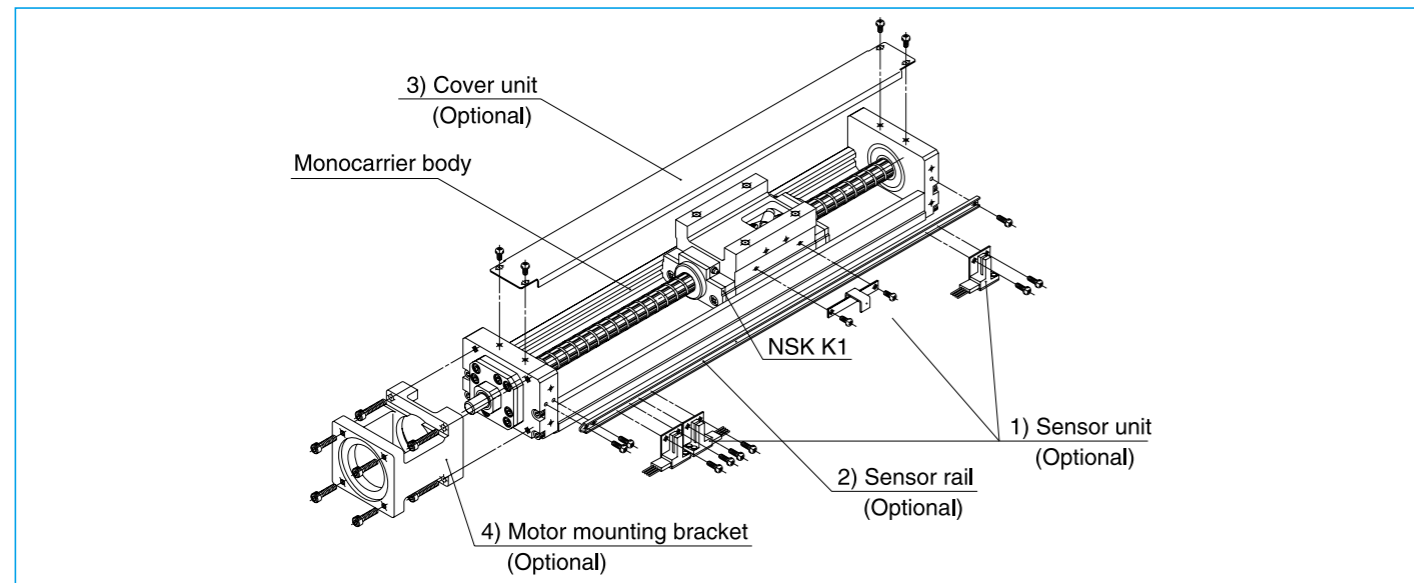

Fig. 3.1 Assembly: Accessories for MCM10 (example)

- 1) Sensor unit: Sensors, sensor mounting parts and a sensor dog are available in a set.
* When a sensor unit is used, the full cover unit cannot be used.
 - 2) Sensor rail: Rail for sensor mounting is available.
 - 3) Cover unit: Top cover or full cover (included top cover and side cover) is available.
 - 4) Motor bracket for motor mounting: Available for a variety of models.
- Note: We assemble accessories upon request.

MCH Series

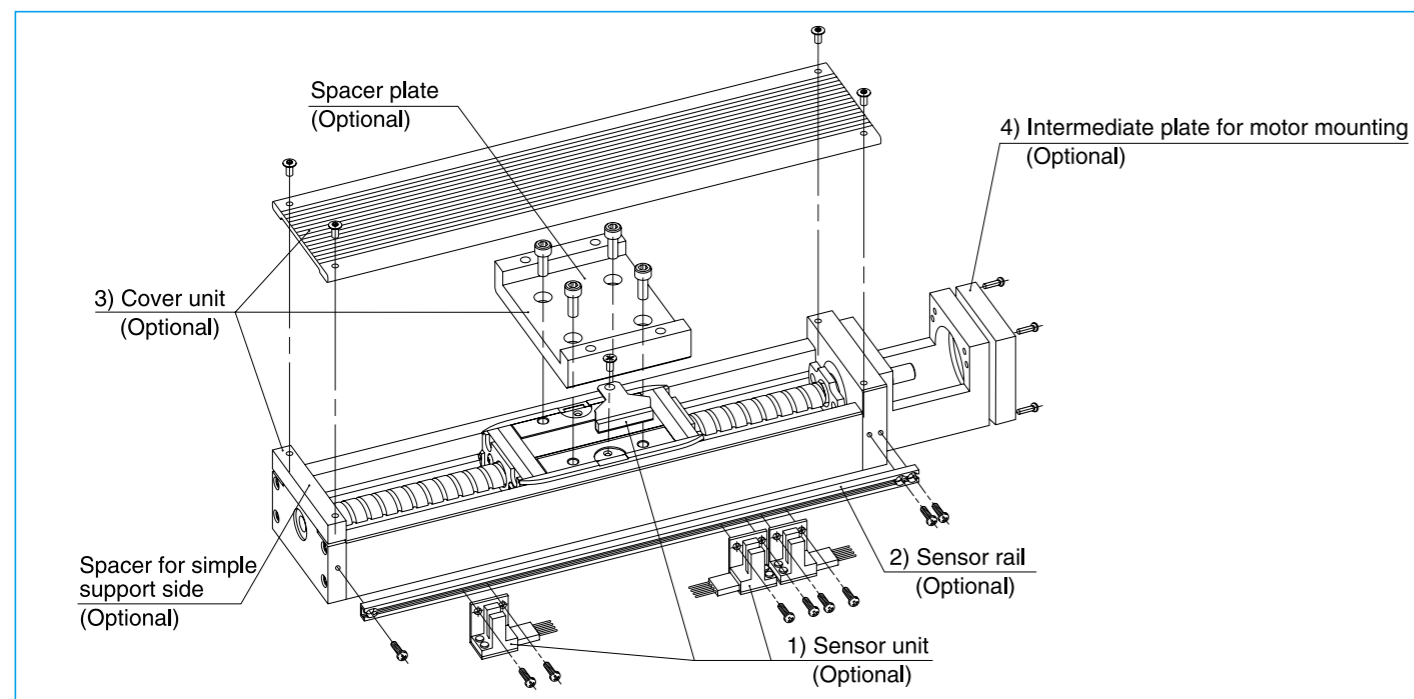

Fig. 3.2 Assembly: Accessories for MCH10 (example)

- 1) Sensor unit: Sensors, sensor mounting parts and a sensor dog are available in a set.
 - 2) Sensor rail: Rail for sensor mounting is available.
 - 3) Cover unit: Top cover (included spacer plate and spacer for simple support side) is available.
 - 4) Intermediate plate for motor mounting: Available for a variety of models.
- Note: We assemble accessories upon request.

1-4 Selection of Monocarrier

1-4. 1 Procedures for Selecting Monocarrier

Select a model number of Monocarrier based on stroke and rigidity (refer to Figs. 4.2, and 4.3).



Select a ball screw lead referring to "1-4.3 Maximum Speed" so that the rotational speed does not exceed the limit.



Study the loads to be applied to the linear guide and obtain the equivalent load (F_e) substituting them for equation 1) or 2) on page 17. Obtain the mean effective load (F_m) substituting them for equation 3) on page 18, then calculate the life.



Study the loads to be applied to the ball screw and support unit. Obtain the mean effective load (F_m) substituting them for equation 3) on page 18, then calculate the life.

1-4. 2 Rigidity

Rigidity of rail

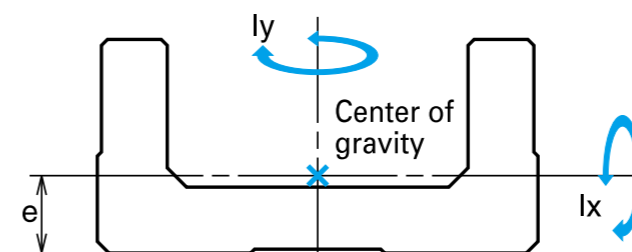

Fig. 4.1

Table 4.1 Rigidity of rail

Model No.	Geometrical moment of inertia $\times 10^4$ (mm ⁴)		Center of gravity (mm)	Mass (kg/100 mm)
	I_x	I_y	e	w
MCM02	0.097	1.32	3.3	0.11
MCM03	0.30	3.3	4.5	0.18
MCM05	0.78	11.4	6.0	0.31
MCM06	2.14	26.1	7.0	0.57
MCM08	5.90	81.0	9.2	0.88
MCM10	15.6	219	12.2	1.52
MCH06	6.5	38.2	10.8	0.67
MCL06	2.58	29.6	7.8	0.56
MCH09	28.7	172	15.5	1.48
MCH10	54.0	307	18	1.93

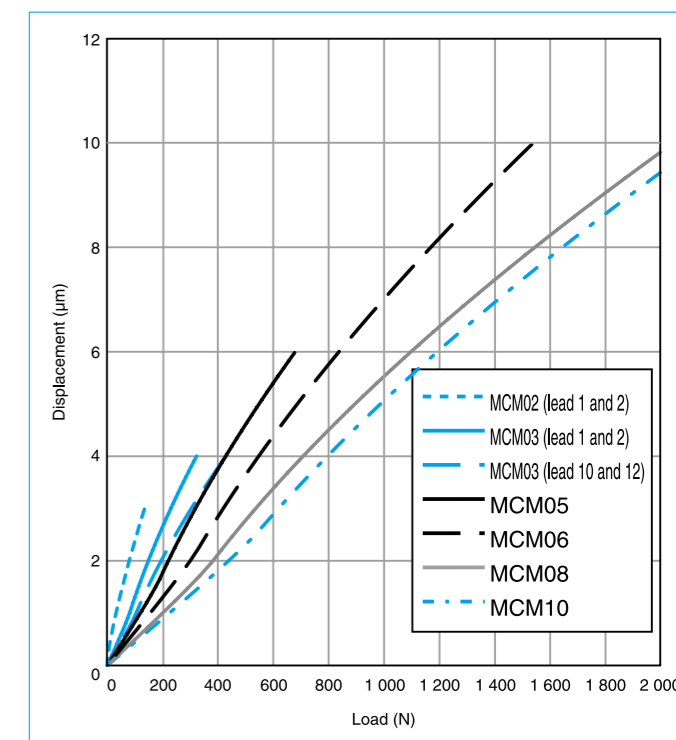

Fig. 4.2 MCM Series rigidity in radial direction

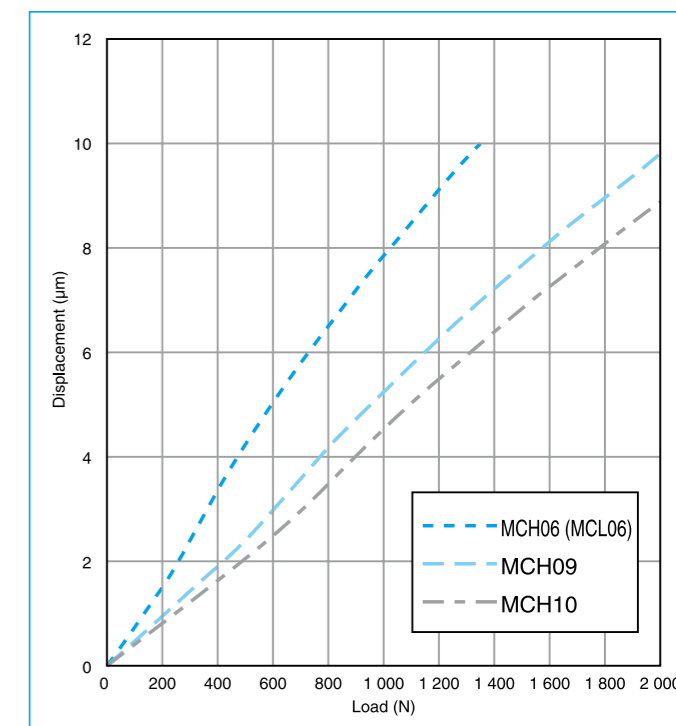

Fig. 4.3 MCH Series rigidity in radial direction

1-4. 3 Maximum Speed

(1) Maximum Speed of MCM Series

Maximum speed of Monocarrier is determined by critical speed of ball screw shaft and $d \cdot n$ value.

Do not exceed maximum speeds on the table below.

Table 4.2

	Ball screw lead	Stroke (mm)	Rail length L ₂ (mm)	Maximum speed (mm/s)	
MCM02 Single slider	1	50	100	50	
		100	150		
		150	200		
	2	50	100	100	
		100	150		
		150	200		
MCM03 Single slider	1	50	115	50	
		100	190		
		150	240		
	2	50	115	100	
		100	190		
		150	240		
	5	50	140	250	
		250	340		
		50	140		
		250	340		
		10	140		500
		250	340		
12	50	140	600		
	250	340			
	50	140			
	250	340			
	15	140		750	
	250	340			
MCM05 Single slider	5	50	180	250	
		600	730		
		50	180		
	10	50	180	500	
		600	730		
		50	180		
	20	50	180	1 000	
		600	730		
		300	430		
		400	530		
		500	630		2 160
		600	730		
30	50	180	2 500		
	600	730			
	1 000	1 180			
	340				
	1 000	1 180		690	
	1 000	1 180			
MCM05 Double slider	10	60	280	500	
		510	730		
		210	430		
	20	510	730	1 000	
		50	190		
		700	840		
MCM06 Single slider	5	700	840	250	
		800	940		
		50	190		
	10	700	840	500	
		800	940		
		300	440		
	20	600	740	1 000	
		700	840		
		990			
		700	840		990
		800	940		
		780			
MCM06 Double slider	5	110	340	250	
		410	640		
		110	340		
	10	710	940	500	
		210	440		
		710	940		
20	210	440	1 000		
	710	940			

Note: When operating Monocarriers near critical speed or exceeding maximum speed in the table, please consult NSK.

	Ball screw lead	Stroke (mm)	Rail length L ₂ (mm)	Maximum speed (mm/s)	
MCM08 Single slider	5	50	220	250	
		700	870		
		800	970		
	10	50	220	500	
		600	770		
		700	870		
		800	970		
		380			
		800	970		
	20	50	220	1 000	
		600	770		
		700	870		
800		970			
770					
800		970			
30	400	570	2 500		
	500	670			
	600	770			
	1 830				
	700	870		1 400	
	800	970			
MCM08 Double slider	10	80	370	500	
		680	970		
		180	470		
	20	680	970	1 000	
		100	280		
		800	980		
MCM10 Single slider	10	900	1 080	420	
		1 000	1 180		
		340			
	20	100	280	1 000	
		800	980		
		900	1 080		
		840			
		840	940		830
		800	940		
	30	500	680	2 500	
		600	780		
		2 430			
700		880	1 870		
800		980			
1 480					
MCM10 Double slider	10	70	380	500	
		670	980		
		870	1 180		
	20	170	480	1 000	
		670	980		
		870	1 180		
910					

Note: When operating Monocarriers near critical speed or exceeding maximum speed in the table, please consult NSK.

(2) Maximum Speed of MCH Series

Maximum speed of Monocarrier is determined by critical speed of ball screw shaft and $d \cdot n$ value.

Do not exceed maximum speeds on the table below.

Table 4.3

	Ball screw lead	Stroke (mm)	Rail length L ₂ (mm)	Maximum speed (mm/s)
MCH06 MCL06 Single slider	5	50	150	250
		500	600	
		50	150	
	10	500	600	500
		50	150	
		50	150	
MCH06 Double slider	5	100	300	250
		300	400	
		100	300	
	10	400	600	500
		400	600	
		1 000		
MCH09 Single slider	5	100	240	250
		700	840	
		800	940	
	10	100	240	500
		700	840	
		800	940	
	20	100	240	1 000
		700	840	
		800	940	
		830		
		800	940	
		830		
MCH09 Double slider	5	150	440	250
		350	640	
		150	440	
	10	650	940	500
		450	440	
		650	940	
20	450	440	1 000	
	650	940		

Note: When operating Monocarriers near critical speed or exceeding maximum speed in the table, please consult NSK.

	Ball screw lead	Stroke (mm)	Rail length L ₂ (mm)	Maximum speed (mm/s)
MCH10 Single slider	10	100	280	500
		800	980	
		900	1 080	
		1 000	1 180	
		1 100	1 280	
		1 200	1 380	
	20	100	280	1 000
		800	980	
		900	1 080	
		1 000	1 180	
		1 100	1 280	
		1 200	1 380	
MCH10 Double slider	10	250	580	500
		650	980	
		750	1 080	
		850	1 180	
		950	1 280	
		1 050	1 380	
	20	250	580	1 000
		750	1 080	
		850	1 180	
		910		
		950	1 280	
		760		
630				

Note: When operating Monocarriers near critical speed or exceeding maximum speed in the table, please consult NSK.

1-4. 4 Accuracy Grade

The accuracy grade of Monocarrier standard series is high grade (H), except for lead 1 and 2 mm of MCM02, and MCM03.

When you require strokes longer than 1 200 mm, please consult NSK about the accuracy grade.

Table 4.4 Unit : μm

Accuracy	High grade (H)			Precision (P)			
	Repeatability	Running Parallelism (vertical)	Backlash	Repeatability	Positioning accuracy	Running Parallelism (vertical)	Backlash
Stroke (mm)							
- 200	±10	14	20 or less	±3	20	8	3 or less
- 400		16			25	10	
- 600		20			30	12	
- 700		23			30	15	
- 1 000		23			35	15	
- 1 200		30			40	20	

1-4. 5 Stroke and Ball Screw Lead

(1) MCM Series Standard Combinations of Stroke and Ball Screw Lead

Table 4.5 Single slider Unit : mm

Model No.	MCM02		MCM03					MCM05				MCM06			MCM08			MCM10						
	Lead	Stroke	1	2	1	2	5	10	12	15	5	10	20	30	5	10	20	5	10	20	30	10	20	30
50	✓	✓	✓	✓	✓	✓	✓	✓	✓	✓	✓	✓	✓	✓	✓	✓	✓	✓	✓	✓	✓	✓	✓	✓
100	✓	✓	✓	✓	✓	✓	✓	✓	✓	✓	✓	✓	✓	✓	✓	✓	✓	✓	✓	✓	✓	✓	✓	✓
150	✓	✓	✓	✓	✓	✓	✓	✓	✓	✓	✓	✓	✓	✓	✓	✓	✓	✓	✓	✓	✓	✓	✓	✓
200					✓	✓	✓	✓	✓	✓	✓	✓	✓	✓	✓	✓	✓	✓	✓	✓	✓	✓	✓	✓
250					✓	✓	✓	✓	✓	✓	✓	✓	✓	✓	✓	✓	✓	✓	✓	✓	✓	✓	✓	✓
300										✓	✓	✓	✓	✓	✓	✓	✓	✓	✓	✓	✓	✓	✓	✓
400										✓	✓	✓	✓	✓	✓	✓	✓	✓	✓	✓	✓	✓	✓	✓
500										✓	✓	✓	✓	✓	✓	✓	✓	✓	✓	✓	✓	✓	✓	✓
600										✓	✓	✓	✓	✓	✓	✓	✓	✓	✓	✓	✓	✓	✓	✓
700															✓	✓	✓	✓	✓	✓	✓	✓	✓	✓
800															✓	✓	✓	✓	✓	✓	✓	✓	✓	✓
900																						✓	✓	✓
1 000																						✓	✓	✓

Table 4.6 Double slider Unit : mm

Model No.	MCM05		MCM06			MCM08			MCM10		
	Lead	Stroke	10	20	5	10	20	10	20	10	20
60	✓										
70										✓	
80									✓		
110	✓		✓	✓							
160	✓										
170										✓	✓
180								✓	✓		
210	✓	✓	✓	✓	✓						
270										✓	✓
280									✓	✓	
310	✓	✓	✓	✓	✓						
370										✓	✓
380									✓	✓	
410	✓	✓	✓	✓	✓						✓
470											✓
480									✓	✓	
510	✓	✓		✓	✓						
570											✓
580									✓	✓	
610					✓	✓					
670										✓	✓
680									✓	✓	
710					✓	✓					
870											✓

Note: Please consult NSK about double slider of MCM02 and MCM03.

(2) MCH Series Standard Combinations of Stroke and Ball Screw Lead

Table 4.7 Single slider Unit : mm

Model No.	MCH06		MCH09			MCH10		
	Lead	Stroke	5	10	20	5	10	20
50	✓	✓	✓					
100	✓	✓	✓	✓	✓	✓	✓	✓
200	✓	✓	✓	✓	✓	✓	✓	✓
300	✓	✓	✓	✓	✓	✓	✓	✓
400	✓	✓	✓	✓	✓	✓	✓	✓
500	✓	✓	✓	✓	✓	✓	✓	✓
600				✓	✓	✓	✓	✓
700				✓	✓	✓	✓	✓
800				✓	✓	✓	✓	✓
900							✓	✓
1 000							✓	✓
1 100							✓	✓
1 200							✓	✓

Table 4.8 Double slider Unit : mm

Model No.	MCH06			MCH09			MCH10	
	Lead	Stroke	5	10	20	5	10	20
100	✓	✓						
150						✓	✓	
200	✓	✓						
250						✓	✓	✓
300	✓	✓						
350						✓	✓	✓
400		✓	✓					
450						✓	✓	✓
550								✓
650						✓	✓	✓
750								✓
850								✓
950								✓
1 050								✓

Table 4.9 Limitations

	Model No.	Lead (mm)	Slider	Stroke (mm)
MCM series	MCM02	1,2	Single	150
	MCM03	1,2	Single	150
		5,10,12,15	Single	350
	MCM05	5,10,20,30*	Single	900
			Double	810
	MCM06	5,10,20	Single	1 000
Double			910	
MCM08	5,10,20,30*	Single	1 000	
		Double	880	
MCM10	10,20,30*	Single	1 750	
		Double	1 600	
MCH series	MCH06	5,10,20	Single	600
			Double	500
	MCH09	5,10,20	Single	1 000
			Double	850
	MCH10	10,20	Single	1 750
			Double	1 600
MCL06	5,10,20	Single	500	

*) Applicable only to single slider

1-4. 6 Basic Load Rating

(1) MCM Series Basic Load Rating

Table 4.10 Basic Load Rating

Model No.	Lead ℓ (mm)	Shaft dia d (mm)	Basic dynamic load rating (N)				Basic static load rating (N)		Support unit Limit load (N)
			Ball screw C_a	Linear guide C	Support unit C_a	Rated running distance L_a (km)	Ball screw C_{0a}	Linear guide C_0	
MCM02	1	$\phi 6$	340(High grade) 405(Precision)	4 910	615	1	555(High grade) 615(Precision)	2 120	490
	2		340(High grade) 405(Precision)	3 900		2	555(High grade) 615(Precision)		
MCM03	1	$\phi 6$	735	10 900	2 670	1	1 230	4 900	1 040
	2		735	8 650		2	2 880		
	5	1 810	7 850	5		2 880			
	10	1 230	6 250	10		1 690	6 620		
	12	1 230	5 880	12		2 680			
15	$\phi 10$	1 760	5 440	15	2 680				
MCM05	5	$\phi 12$	3 760	15 600	4 400	5	6 310	10 900	1 450
	10		2 420	12 400		10	3 790		
	20		2 420	9 850		20	3 790		
	30		3 260	8 600		30	5 400	2 730	
MCM06	5	$\phi 15$	7 070	25 200	6 550	5	12 800	17 000	2 730
	10		7 070	20 000		10	12 800		
	20		4 560	15 900		20	7 730		
MCM08	5	$\phi 15$	7 070	30 800	7 100	5	12 800	22 800	3 040
	10		7 070	24 400		10	12 800		
	20		4 560	19 400		20	7 730		
	30		5 070	16 930		30	8 730		
MCM10	10	$\phi 20$	11 000	33 500	7 600	10	21 100	29 400	3 380
	20		7 060	26 600		20	12 700		
	30		11 700	23 200		30	22 700		

Notes: ●Basic dynamic and static load ratings indicate values for one slider. ●Basic dynamic load rating of linear guide is load of perpendicular direction to the axis that allows 90% of a group of the same Monocarriers to operate "Rated running distance" in table, that is equivalent to 1 million revolutions of ball screw and support unit under the same conditions without causing flaking by rolling contact fatigue. ●Basic dynamic load rating of ball screw is load in the axial direction that allows 90% of ball screws of a group of the same Monocarriers to rotate 1 million revolutions under the same conditions without causing flaking by rolling contact fatigue. ●Basic dynamic load rating of support unit is constant load in the axial direction that allows 90% of support units of the same group of Monocarriers to rotate 1 million revolutions under the same conditions without causing flaking by rolling contact fatigue. ●Basic static load rating is load that results in combined permanent deformations at contact points of balls and ball grooves of respective parts at a diameter of 0.01%.

Table 4.11 Basic static moment load of linear guide

Model No.	Lead (mm)	Slider	Basic static moment (N · m)		
			Rolling M_{RO}	Pitching M_{PO}	Yawing M_{YO}
MCM02	1, 2	Single	24	8	8
MCM03	1, 2		68	28	28
MCM03	5, 10, 12, 15	Single	92	51	51
			MCM05	5, 10, 20, 30*	Single
MCM05	5, 10, 20, 30*	Double	455	765	765
		MCM06	5, 10, 20	Single	415
MCM06	5, 10, 20	Double	825	1 220	1 220
		MCM08	5, 10, 20, 30*	Single	770
MCM08	5, 10, 20, 30*	Double	1 540	2 050	2 050
		MCM10	10, 20, 30*	Single	1 170
Double	2 340			2 940	2 940

Notes: ● Basic static moment of double slider is value when two sliders equipped with NSK K1 are butted against each other.

● Basic static moment is value when rolling contact pressure of balls exceeds 4 000 N/mm².
● If extremely heavy load is required, please consult NSK for estimation of fatigue life.

*) Applicable only to single slider

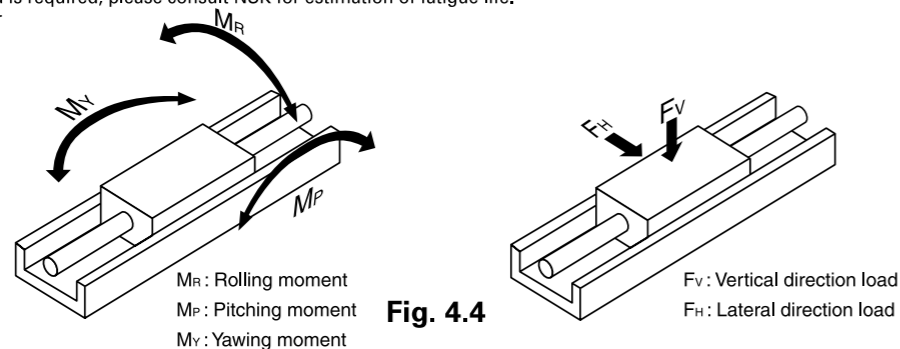

Fig. 4.4

(2) MCH Series Basic Load Rating

Table 4.12 Basic Load Rating

Model No.	Lead ℓ (mm)	Shaft dia d (mm)	Basic dynamic load rating (N)				Basic static load rating (N)		Support unit Limit load (N)
			Ball screw C_a	Linear guide C	Support unit C_a	Rated running distance L_a (km)	Ball screw C_{0a}	Linear guide C_0	
MCH06 (MCL06)	5	$\phi 12$	3 760	22 800	4 400	5	6 310	16 300	1 450
	10		2 420	18 100		10	3 790		
	20		2 420	14 400		20	3 790		
MCH09	5	$\phi 15$	7 070	40 600	7 100	5	12 800	30 500	3 040
	10		7 070	32 200		10	12 800		
	20		4 560	25 500		20	7 730		
MCH10	10	$\phi 20$	11 000	44 600	7 600	10	21 100	42 000	3 380
	20		7 060	35 400		20	12 700		

Notes: ●Basic dynamic and static load ratings indicate values for one slider. ●Basic dynamic load rating of linear guide is load of perpendicular direction to the axis that allows 90% of a group of the same Monocarriers to operate "Rated running distance" in table, that is equivalent to 1 million revolutions of ball screw and support unit under the same conditions without causing flaking by rolling contact fatigue. ●Basic dynamic load rating of ball screw is load in the axial direction that allows 90% of ball screws of a group of the same Monocarriers to rotate 1 million revolutions under the same conditions without causing flaking by rolling contact fatigue. ●Basic dynamic load rating of support unit is constant load in the axial direction that allows 90% of support units of the same group of Monocarriers to rotate 1 million revolutions under the same conditions without causing flaking by rolling contact fatigue. ●Basic static load rating is load that results in combined permanent deformations at contact points of balls and ball grooves of respective parts at a diameter of 0.01%.

Table 4.13 Basic static moment load of linear guide

Model No.	Slider	Basic static moment (N · m)		
		Rolling M_{RO}	Pitching M_{PO}	Yawing M_{YO}
MCH06 (MCL06)	Single	335	133	133
	Double	770	730	730
MCH09	Single	890	385	385
	Double	1 780	2 070	2 070
MCH10	Single	1 460	610	610
	Double	2 920	3 430	3 430

Notes: ● Basic static moment of double slider is value when two sliders equipped with NSK K1 are butted against each other.

● Basic static moment is value when rolling contact pressure of balls exceeds 4 000 N/mm².

● If extremely heavy load is required, please consult NSK for estimation of fatigue life.

*) Applicable only to single slider

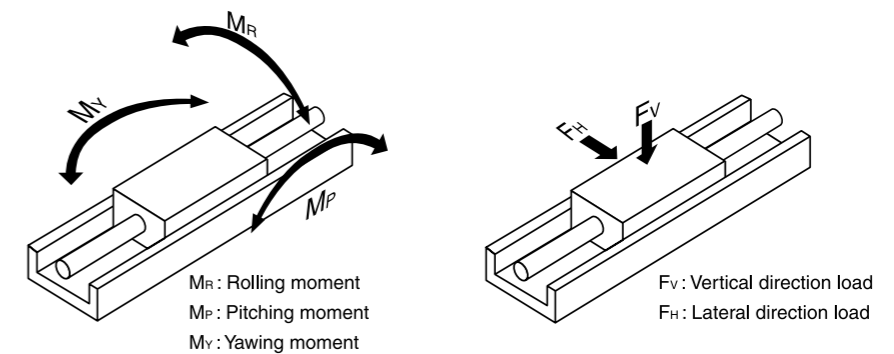

Fig. 4.5

1-4. 7 Estimation of Life Expectancy

(1) Life of Linear Guide

Study the load to be applied to the linear guide of Monocarrier (Fig. 4.6). The equivalent load (F_e) is determined by substituting the load for equation 1) (Eq. 2): in case of the tightly coupled double slider type).

● In case of the single slider

$$F_e = Y_H \cdot F_H + Y_V \cdot F_V + Y_R \cdot \epsilon_R \cdot M_R + Y_P \cdot \epsilon_P \cdot M_P + Y_Y \cdot \epsilon_Y \cdot M_Y \dots\dots\dots 1)$$

● In case of the double slider

$$F_e = \frac{Y_H \cdot F_H}{2} + \frac{Y_V \cdot F_V}{2} + Y_R \cdot \epsilon_{Rd} \cdot M_R + Y_P \cdot \epsilon_{Pd} \cdot M_P + Y_Y \cdot \epsilon_{Yd} \cdot M_Y \dots\dots\dots 2)$$

- F_H : Lateral direction load acting on the slider (N)
- F_V : Vertical direction load acting on the slider (N)
- M_R : Rolling moment acting on the slider (N · m)
- M_P : Pitching moment acting on the slider (N · m)
- M_Y : Yawing moment acting on the slider (N · m)

- $\epsilon_R, \epsilon_{Rd}$: Dynamic equivalent coefficient to rolling moment
- $\epsilon_P, \epsilon_{Pd}$: Dynamic equivalent coefficient to pitching moment
- $\epsilon_Y, \epsilon_{Yd}$: Dynamic equivalent coefficient to yawing moment

Refer to **Table 4.14** about Dynamic equivalent coefficient.

- Y_H, Y_V, Y_R, Y_P, Y_Y : 1.0 or 0.5

At equations 1) and 2) for obtaining equivalent load F_e , among $F_H, F_V, \epsilon_P M_P, \epsilon_R M_R, \epsilon_Y M_Y$, the maximum load is assumed to be 1.0, and others are to be 0.5.

Table 4.14 Dynamic equivalent coefficient

Model No.	MCM02	MCM03		MCM05	MCM06	MCM08	MCM10	MCH06 MCL06	MCH09	MCH10
		Lead 1, 2	Lead 5, 10, 12, 15							
ϵ_R	95.2	79.4	79.4	52.6	45.5	32.5	27.8	48.3	34.5	28.6
ϵ_P	174	113.9	84.2	81.3	65.1	48.8	45.2	75.1	47.9	41.0
ϵ_Y	174	113.9	84.2	81.3	65.1	48.8	45.2	75.1	47.9	41.0
ϵ_{Rd}	—	—	—	26.3	22.7	16.3	13.9	24.2	17.2	14.3
ϵ_{Pd}	—	—	—	10.4 (12.2)	9.7 (11.5)	7.6 (8.6)	7.1 (8.0)	11.4 (13.2)	8.11 (9.10)	6.98 (7.82)
ϵ_{Yd}	—	—	—	10.4 (12.2)	9.7 (11.5)	7.6 (8.6)	7.1 (8.0)	11.4 (13.2)	8.11 (9.10)	6.98 (7.82)

Note: Parenthesized figures are dynamic equivalent coefficient in case of the Monocarrier without NSK K1.

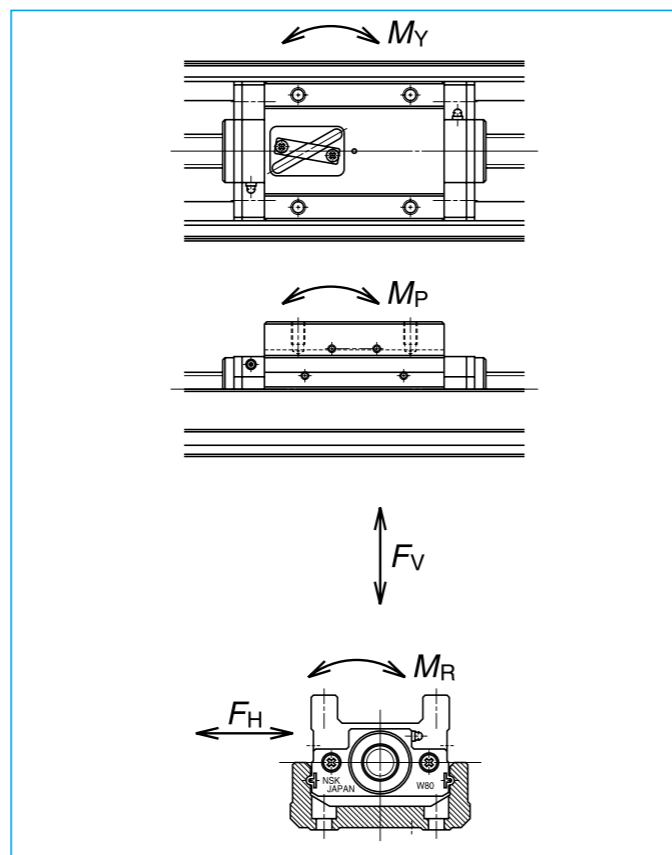

Fig. 4.6 Direction of load

In case when the load acting on the slider may fluctuate (In general, M_P, M_Y may fluctuate with the acceleration/deceleration of slider), the mean effective load is determined by Eq. 3).

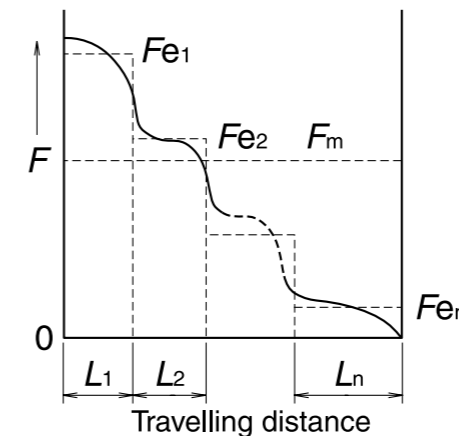

Fig. 4.7 Stepwise Fluctuating Load

- Travelling distance under the equivalent load F_{e1} : L_1
- Travelling distance under the equivalent load F_{e2} : L_2
-
- Travelling distance under the equivalent load F_{en} : L_n

$$F_m = \sqrt[3]{\frac{1}{L} (F_{e1}^3 L_1 + F_{e2}^3 L_2 + \dots + F_{en}^3 L_n) \dots 3)}$$

- F_m : Mean effective load of fluctuating loads
- L : Total travelling distance

The life of linear guide is calculated by Eq. 4).

$$L = L_a \times \left(\frac{C}{f_w \cdot F_m} \right)^3 \dots\dots\dots 4)$$

- L : Life of linear guide (km)
- F_m : Mean effective load acting on the linear guide (N)
- C : Basic dynamic load rating of the linear guide (N)
- L_a : Travelling distance (km)
- f_w : Load factor (refer to **Table 4.15**)

When the estimated life does not clear the required life, the life of the linear guide is to be calculated again after the following measures are taken:

1. Change from the single slider type to double slider type.
2. Use a larger size Monocarrier.

(2) Life of Ball Screw (Support unit)

The mean effective load is determined from the axial loads.

For calculation of the mean effective load, use Eq. 3.

The life of ball screw is calculated by Eq. 5).

$$L = \ell \times \left(\frac{C_a}{f_w \cdot F_m} \right)^3 \times 10^6 \dots\dots\dots 5)$$

- ℓ : Lead of ball screw (mm)
- L : Life of ball screw (km)
- C_a : Basic dynamic load rating of the ball screw (N)
- F_m : Mean effective load acting on the ball screw (N)
- f_w : Load factor (refer to **Table 4.15**)

The life of a support unit is calculated by Eq. 5). If the life of ball screw/support unit does not clear the required life, use a larger size Monocarrier. After applying the calculations mentioned above, selection of the Monocarrier is completed.

Table 4.15 Values of load factor f_w

Operating conditions	Load factor f_w
At smooth operation with no mechanical shock	1.0 – 1.2
At normal operation	1.2 – 1.5
At operation with mechanical shock and vibrations	1.5 – 3.0

1-4. 8 Example of Life Estimation

This section offers an example how to estimate the life of Monocarrier based on the life of each component.

<<Example of calculation-1>>

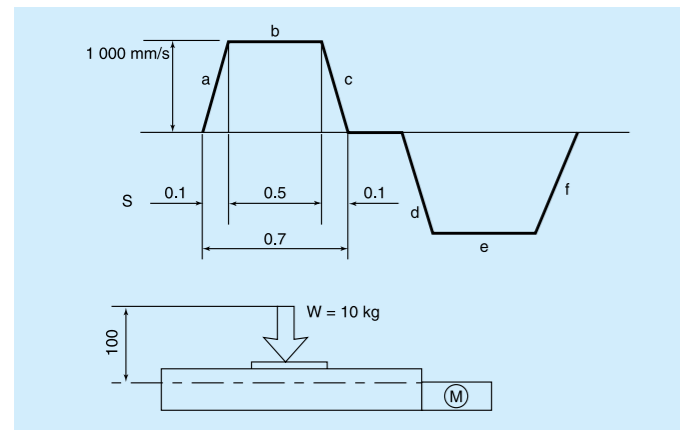

Fig. 4.8

1. Use condition

- Stroke : 600 mm
- Maximum speed : 1000 mm/s
- Load mass : W = 10 kg
- Acceleration : g = 9.8 m/s²
- Setting position : Horizontal
- Operating profile : See above figure

2. Selection of Model number (Interim Selection)
 Firstly, select a greater ball screw lead as the maximum speed is 1000 mm/s. The interim selection is MCM06060H20K00, a single slider specification MCM06 that has 600 mm stroke, as the stroke is 600 mm.

3. Calculation

3-1. Linear guide

3-1-1. Fatigue life:

Multiply the result of the Eq. 1) by the dynamic equivalent coefficient (Table 4.14 single slider) to convert the load volume. From above operation profile,

i) Constant speed

$$Fe_1 = Y_V \cdot F_V = Y_V \cdot W \cdot g$$

$$= 1 \cdot 10 \cdot 9.8 = 98 \text{ N}$$

ii) Accelerating

$$Fe_2 = Y_V \cdot F_V + Y_P \cdot \epsilon_P \cdot M_P$$

$$= 0.5 \cdot 10 \cdot 9.8 + 1 \cdot 65.1 \cdot 0.1 \cdot 100 = 700 \text{ N}$$

iii) Decelerating

$$Fe_3 = Y_V \cdot F_V + Y_P \cdot \epsilon_P \cdot M_P$$

$$= 0.5 \cdot 10 \cdot 9.8 + 1 \cdot 65.1 \cdot 0.1 \cdot 100 = 700 \text{ N}$$

Mean effective load *Fm*

$$Fm = \sqrt[3]{\frac{1}{L} (Fe_1^3 \cdot L_1 + Fe_2^3 \cdot L_2 + Fe_3^3 \cdot L_3)}$$

$$= \sqrt[3]{\frac{1}{600} (98^3 \cdot 500 + 700^3 \cdot 50 + 700^3 \cdot 50)}$$

$$= 387 \text{ N}$$

$$L = \left(\frac{C_a}{f_w \cdot F_m} \right)^3 \times L_a$$

$$= \left(\frac{15\,900}{1.2 \cdot 387} \right)^3 \times 20$$

$$= 8.02 \times 10^5 \text{ km}$$

3-1-2. Static safety factor: Divide the basic static load rating by the maximum load.

$$F_s = \frac{C_0}{F_e} = \frac{C_0}{F_{e2}} = \frac{17\,000}{700} = 24.2$$

3-2. Ball screw

3-2-1. Fatigue life: Obtain the axial load of each stage of operation referring to the operation profile, then calculate the mean load.

By the process above,

i) Constant speed

$$Fe_1 = \mu \cdot W \cdot g = 0.01 \cdot 10 \cdot 9.8 = 0.98$$

ii) Accelerating

$$Fe_2 = Fe_1 + W \cdot \alpha = 101 \text{ N}$$

iii) Decelerating

$$Fe_3 = Fe_1 - W \cdot \alpha = 99 \text{ N}$$

Axial mean effective load *Fm*

$$Fm = \sqrt[3]{\frac{1}{L} (Fe_1^3 \cdot L_1 + Fe_2^3 \cdot L_2 + Fe_3^3 \cdot L_3)}$$

$$= \sqrt[3]{\frac{1}{600} (0.98^3 \cdot 500 + 101^3 \cdot 50 + 99^3 \cdot 50)}$$

$$= 55 \text{ N}$$

$$L = \left(\frac{C_a}{f_w \cdot F_m} \right)^3 \times \ell \times 10^6$$

$$= \left(\frac{4\,560}{1.2 \cdot 55} \right)^3 \times 20 \times 10^6 \text{ (mm)}$$

$$= 6.5 \times 10^6 \text{ km}$$

3-2-2. Static safety factor: Divide the basic static load rating by the maximum axial load.

$$F_s = \frac{C_{0a}}{F_e} = \frac{C_{0a}}{F_{e2}} = \frac{7\,730}{101} = 76.5$$

3-2-3. Maximum rotational speed: According to the table of maximum speed on page 9, MCM06 with 20 mm lead and 600 mm stroke, is possible to operate under the maximum speed of 1 000 mm/s.

3-3. Support unit

3-3-1. Fatigue life: Use the axial load *Fm* = 55 N, that is the result of above calculation 3-2-1.

$$L = \left(\frac{C_a}{f_w \cdot F_m} \right)^3 \times \ell \times 10^6 = \left(\frac{6\,550}{1.2 \cdot 55} \right)^3 \times 20 \times 10^6 \text{ (mm)}$$

$$= 1.95 \times 10^7 \text{ km}$$

3-3-2. Static safety factor: Divide the limit load by the maximum axial load.

$$F_s = \frac{C_{0a}}{F_e} = \frac{C_{0a}}{F_{e2}} = \frac{2\,730}{101} = 27.0$$

3-4. Result

MCM06060H20K00	Linear guide	Ball screw	Support unit
	8.02 × 10 ⁵ km	6.5 × 10 ⁶ km	1.95 × 10 ⁷ km
Fatigue life	10 ⁵ km	10 ⁶ km	10 ⁷ km
Static safety factor	24.2	76.5	27.0

In this case, the linear guide has the shortest fatigue life of the components. Therefore, the linear guide fatigue life is used as the life of the Monocarrier. The interim selection of MCM06060H20K00, that is chosen based on the use conditions, satisfies the required life.

<<Example of calculation-2>>

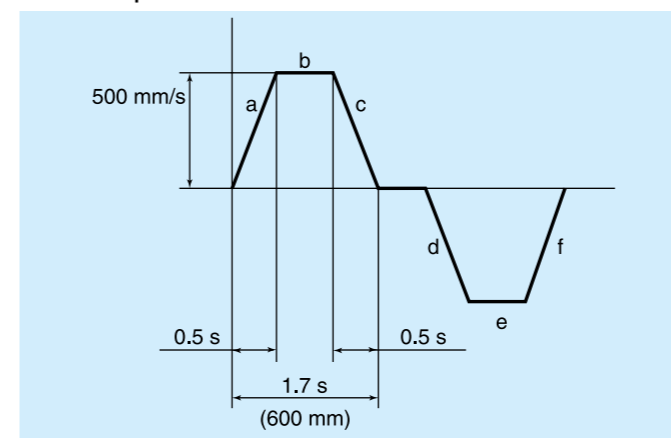

Fig. 4.9

1. Use condition

- Stroke : 600 mm
- Maximum speed : 500 mm/s
- Load mass : W = 20 kg
- Acceleration : 9.8 m/s²
- Setting position : Horizontal
- Operating profile : See above figure

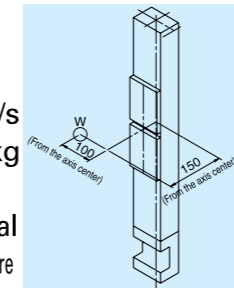

Fig. 4.10

2. Selection of Model number (Interim Selection)
 Select a 10 mm lead ball screw as the maximum speed is 500 mm/s.

The interim selection is MCM08068H10D00 as a double slider specification of MCM08 has 680 mm stroke, and the setting position is vertical.

3. Calculation

3-1. Linear guide

3-1-1. Fatigue life: Multiply the result of the Eq. 2) by the dynamic equivalent coefficient (Table 4.14, double slider) to convert the load volume. From operation profile (Fig. 4.9), the acceleration is 1 m/s².

i) Constant speed $Fe_1 = Y_P \cdot \epsilon_{Pd} \cdot M_P + Y_V \cdot \epsilon_{Vd} \cdot M_V$

$$= 1 \cdot 7.6 \cdot 20 \cdot 9.8 \cdot 0.15 + 0.5 \cdot 7.6 \cdot 20 \cdot 9.8 \cdot 0.1 = 298 \text{ N}$$

ii) Accelerating $Fe_2 = Y_P \cdot \epsilon_{Pd} \cdot M_P + Y_V \cdot \epsilon_{Vd} \cdot M_V$

$$= 1 \cdot 7.6 \cdot 20 \cdot (9.8 + 1.0) \cdot 0.15 + 0.5 \cdot 7.6 \cdot 20 \cdot (9.8 + 1.0) \cdot 0.1 = 329 \text{ N}$$

iii) Decelerating $Fe_3 = Y_P \cdot \epsilon_{Pd} \cdot M_P + Y_V \cdot \epsilon_{Vd} \cdot M_V$

$$= 1 \cdot 7.6 \cdot 20 \cdot (9.8 - 1.0) \cdot 0.15 + 0.5 \cdot 7.6 \cdot 20 \cdot (9.8 - 1.0) \cdot 0.1 = 268 \text{ N}$$

Mean effective load *Fm*

$$Fm = \sqrt[3]{\frac{1}{L} (Fe_1^3 \cdot L_1 + Fe_2^3 \cdot L_2 + Fe_3^3 \cdot L_3)}$$

$$= \sqrt[3]{\frac{1}{600} (298^3 \cdot 350 + 329^3 \cdot 125 + 268^3 \cdot 125)}$$

$$= 300 \text{ N}$$

$$L = L_a \times \left(\frac{C_a}{f_w \cdot F_m} \right)^3$$

$$= 10 \times \left(\frac{24\,400}{1.2 \cdot 300} \right)^3$$

$$= 3.11 \times 10^6 \text{ km}$$

3-1-2. Static safety factor: Divide the basic static load rating by the maximum load.

$$F_s = \frac{C_0}{F_e} = \frac{C_0}{F_{e2}} = \frac{22\,800}{329} = 69.3$$

3-2. Ball screw

3-2-1. Fatigue life: Obtain the axial load of each stage of operation referring to the operation profile, then calculate the mean load.

i) Constant speed

$$Fe_1 = W \cdot g = 20 \cdot 9.8 = 196 \text{ N}$$

ii) Accelerating

$$Fe_2 = Fe_1 + W \cdot \alpha = 196 + 20 \cdot 1 = 216 \text{ N}$$

iii) Decelerating

$$Fe_3 = Fe_1 - W \cdot \alpha = 196 - 20 \cdot 1 = 176 \text{ N}$$

Axial mean effective load F_m

$$F_m = \sqrt[3]{\frac{1}{L} (Fe_1^3 \cdot L_1 + Fe_2^3 \cdot L_2 + Fe_3^3 \cdot L_3)}$$

$$= \sqrt[3]{\frac{1}{600} (196^3 \cdot 350 + 216^3 \cdot 125 + 176^3 \cdot 125)}$$

$$= 197 \text{ N}$$

$$L = \ell \times \left(\frac{C_a}{f_w \cdot F_m} \right)^3 \times 10^6$$

$$= 10 \times \left(\frac{7\,070}{1.2 \cdot 197} \right)^3 \times 10^6 \text{ (mm)}$$

$$= 2.67 \times 10^5 \text{ km}$$

3-2-2. Static safety factor: Divide the basic static load rating by the maximum axial load.

$$F_s = \frac{C_{0a}}{F_e} = \frac{C_{0a}}{F_{e_2}} = \frac{12\,800}{216} = 59.2$$

3-3. Support unit

3-3-1. Fatigue life: Use the axial load $F_m = 197 \text{ N}$, that is the result of above calculation 3-2-1.

$$L = \ell \times \left(\frac{C_a}{f_w \cdot F_m} \right)^3 \times 10^6 = 10 \times \left(\frac{7\,100}{1.2 \times 197} \right)^3 \times 10^6 \text{ (mm)}$$

$$= 2.70 \times 10^5 \text{ km}$$

3-3-2. Static safety factor: Divide the limit load by the maximum axial load.

$$F_s = \frac{C_{0a}}{F_e} = \frac{C_{0a}}{F_{e_2}} = \frac{3\,040}{216} = 14.0$$

3-4. Result

MCM08068H10D00	Linear guide	Ball screw	Support unit
Fatigue life	3.11 × 10 ⁶ km	2.67 × 10 ⁵ km	2.70 × 10 ⁵ km
Static safety factor	69.3	59.2	14.0



1-5 MCM Series

1-5.1 MCM Series Reference Number 25
Coding

1-5.2 MCM Series Dimension Table of
Standard Products

MCM02 26

MCM03 27

MCM05 31

MCM06 35

MCM08 39

MCM10 43

1-5.3 MCM Series Accessories

1-5.3. 1 Sensor Unit 47

1-5.3. 2 Cover Unit 51

1-5.3. 3 Motor Bracket 53

MCM Series

1-5 MCM Series

1-5.1 MCM Series Reference Number Coding

[Body]

Example: **MC M 08 040 H 10 K 0 0** *1

Monocarrier

M type: MCM Series

Nominal size (rail width, Unit: 10 mm)

Stroke (Unit: 10 mm)

Accuracy grade (H, high grade; P, precision grade)

NSK management number (0 or 2)

Standard grease specification: O (AS2)
Clean grease specification: B (LG2)

Slider specification K: Single slider
D: Double slider (See page 13.)

Ball screw lead (mm)

Note: *1. 14th digit is control No. of NSK. Customers cannot specify a number. See the pages of each nominal number for details.

[With Accessories]

Example: **MC E 08 040 H 10 K 0 0 K 0 0 0**

E: With MCM Accessories

NSK management number

Sensor unit

Cover unit

Motor bracket

Note: Accessories are available separately.

Table 1 Sensor unit (See page 47.)

Reference No. code	Specification	Reference No.
0	N/A	—
1	Proximity switch (normally close contact 3 pieces)	MC - SRxx - 10
2	Proximity switch (normally open contact 3 pieces)	MC - SRxx - 11
3	Proximity switch (normally open contact 1 piece, normally close contact 2 pieces)	MC - SRxx - 12
4	Photo sensor 3 pieces	MC - SRxx - 13

Note 1) xx: Reference number
2) Sensor rail is not included in sensor unit. If you require the rail, please request separately. (See page 48 to 50.)

Table 2 Cover unit (See pages 51 to 52.)

Reference No. code	Specification	Reference No.
0	N/A	—
1	With top cover	MC - CVxxxx - 01 (02) *
2	Full cover	MC - CVxxxx - 00

Note 1) xxxx: Reference number and stroke number 2)*: "-02" is only used for Monocarrier MCM03.
3) When a sensor unit is used, full cover unit cannot be used.

Table 3 Motor bracket (See pages 53 to 69.)

Reference No. code	Reference No.				
	MCM03	MCM05	MCM06	MCM08	MCM10
0	N/A	N/A	N/A	N/A	N/A
1	MC-BK03-146-00	MC-BK05-145-00	MC-BK06-145-00	MC-BK08-145-00	MC-BK10-170-00
2	MC-BK03-148-01	MC-BK05-146-00	MC-BK06-146-00	MC-BK08-146-00	MC-BK10-170-01
3	MC-BK03-231-00	MC-BK05-148-00	MC-BK06-148-00	MC-BK08-160-00	MC-BK10-190-00
4	—	MC-BK05-160-00	MC-BK06-160-00	MC-BK08-170-00	MC-BK10-270-00
5	—	MC-BK05-250-00	MC-BK06-170-00	MC-BK08-170-01	—
6	—	—	MC-BK06-170-01	MC-BK08-190-00	—
7	—	—	MC-BK06-250-00	MC-BK08-250-00	—
8	—	—	—	MC-BK08-270-00	—

N/A: Not applicable

1-5.2 MCM Series Dimension Table of Standard Products

MCM02

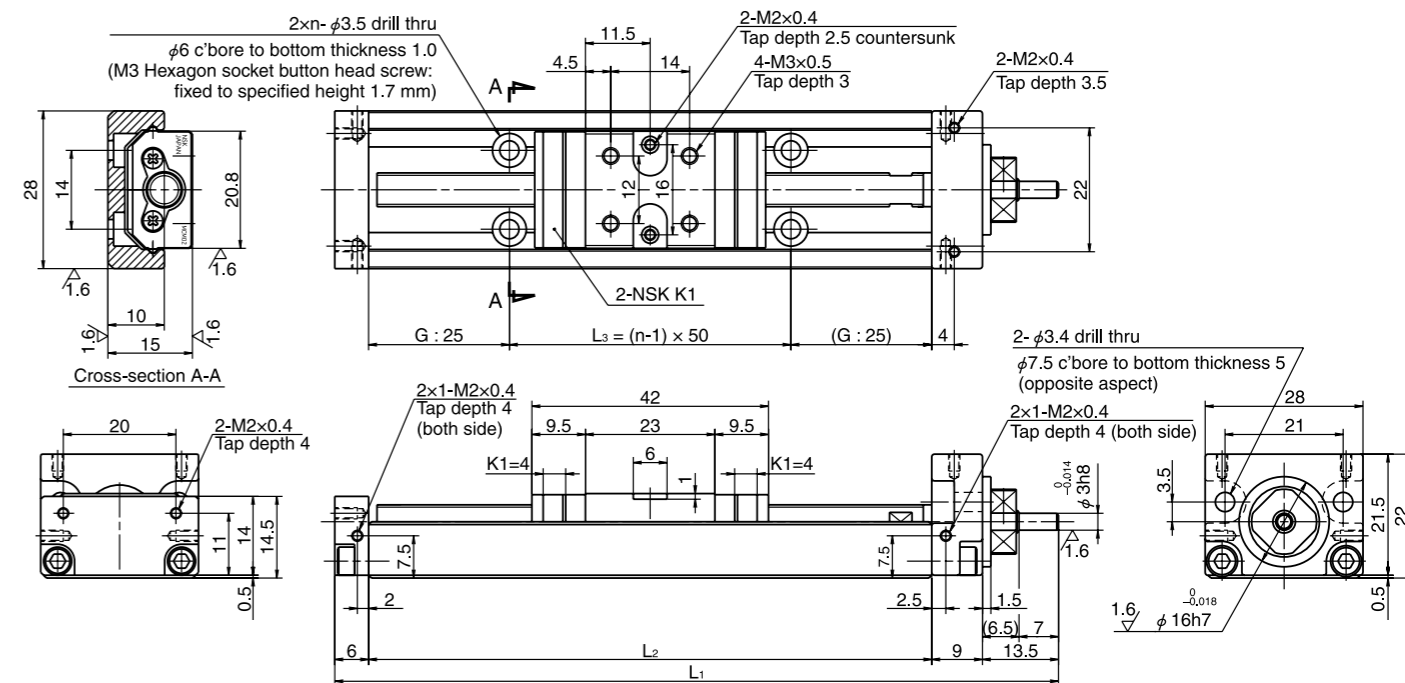

Dimension of MCM02 (Single slider)

Reference No.	Nominal stroke (mm)	Stroke limit (mm)	Ball screw lead (mm)	Body length (mm)			No. of mounting hole n	Inertia × 10 ⁻⁷ (kg · m ²)	Mass (kg)
				L ₁	L ₂	L ₃			
MCM02005H01K	50	58	1	128.5	100	50	2	0.93	0.26
MCM02005P01K									
MCM02005H02K									
MCM02005P02K	100	108	2	178.5	150	100	3	1.36	0.32
MCM02010H01K									
MCM02010P01K									
MCM02010H02K	150	158	1	228.5	200	150	4	1.81	0.39
MCM02010P02K									
MCM02015H01K									
MCM02015P01K	150	158	2	228.5	200	150	4	1.81	0.39
MCM02015H02K									
MCM02015P02K									

Monocarrier dynamic torque specification (N · cm)

Ball screw lead (mm)	High grade		Precision	
	1	2	0.1 - 1.3	0.2 - 1.6
1				
2				

Notes:
1. Frictional resistance of NSK K1 is included in dynamic torque in table.
2. Grease is packed into ball screw, linear guide parts and support unit.
3. Consult NSK for life estimates under large moment loads.

Basic load rating

Lead ℓ (mm)	Shaft dia d (mm)	Basic dynamic load rating (N)				Basic static load rating (N)		Support unit load limit (N)
		Ball screw C _a	Linear guides C	Support unit C _a	Rated running distance L _a (km)	Ball screw C _{0a}	Linear guides C ₀	
1	φ 6	340 (High grade) 405 (Precision)	4 910	615	1	555 (High grade) 615 (Precision)	2 120	490
2		340 (High grade) 405 (Precision)				3 900		

Basic static moment load of linear guide

Slider	Basic static moment load (N · m)		
	Rolling M _{RO}	Pitching M _{PO}	Yawing M _{YO}
Single	24	8	8

MCM03

Accuracy grade: Precision (P)

Ball screw lead 1 and 2

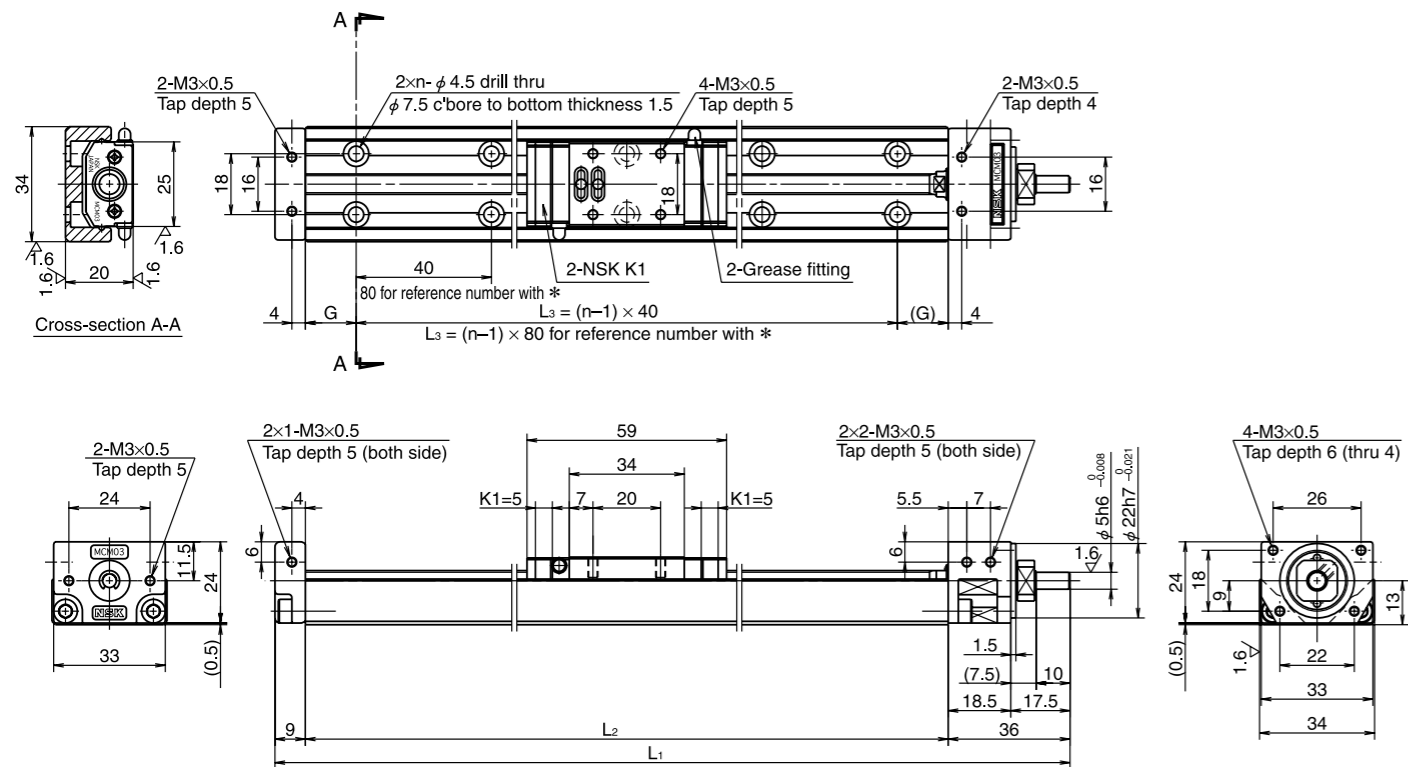

Dimension of MCM03 (Single slider)

Reference No.	Nominal stroke (mm)	Stroke limit (mm) (without K1)	Ball screw lead (mm)	Body length (mm)				No. of mounting hole <i>n</i>	Inertia $\times 10^{-5}$ (kg · m ²)	Mass (kg)
				L ₁	L ₂	G	L ₃			
*MCM03005P01K00	50	56	1	160	115	17.5	80	2	0.015	0.6
*MCM03005P02K00		(66)	2							
MCM03010P01K00	100	131	1	235	190	15	160	5	0.021	0.7
MCM03010P02K00		(141)	2							
MCM03015P01K00	150	181	1	285	240	20	200	6	0.025	0.8
MCM03015P02K00		(191)	2							

Note: Bolt hole pitch L₃ on items marked with * is 80 mm.

Monocarrier dynamic torque specification (N · cm)

Ball screw lead (mm)	1	0.2 – 1.7
	2	

Notes:

- Frictional resistance of NSK K1 is included in dynamic torque in table.
- Grease is packed into ball screw, linear guide parts and support unit.
- Consult NSK for life estimates under large moment loads.
- A spacer plate is required when using a cover unit or sensor unit for MCM03 with the lead of 1 or 2 mm. (See page 51.)

Basic load rating

Lead <i>l</i> (mm)	Shaft dia <i>d</i> (mm)	Basic dynamic load rating (N)				Basic static load rating (N)			Support unit load limit (N)
		Ball screw <i>C_a</i>	Linear guides <i>C</i>	Support unit <i>C_a</i>	Rated running distance <i>L_a</i> (km)	Ball screw <i>C_{0a}</i>	Linear guides <i>C₀</i>	Support unit	
1	φ6	735	10 900	2 670	1	1 230	4 900	1 040	
2		735	8 650						

Basic static moment load of linear guide

Slider	Basic static moment load (N · m)		
	Rolling M _{RO}	Pitching M _{PO}	Yawing M _{YO}
Single	68	28	28

MCM03

Accuracy grade: High grade (H)

Ball screw lead 5, 10 and 12

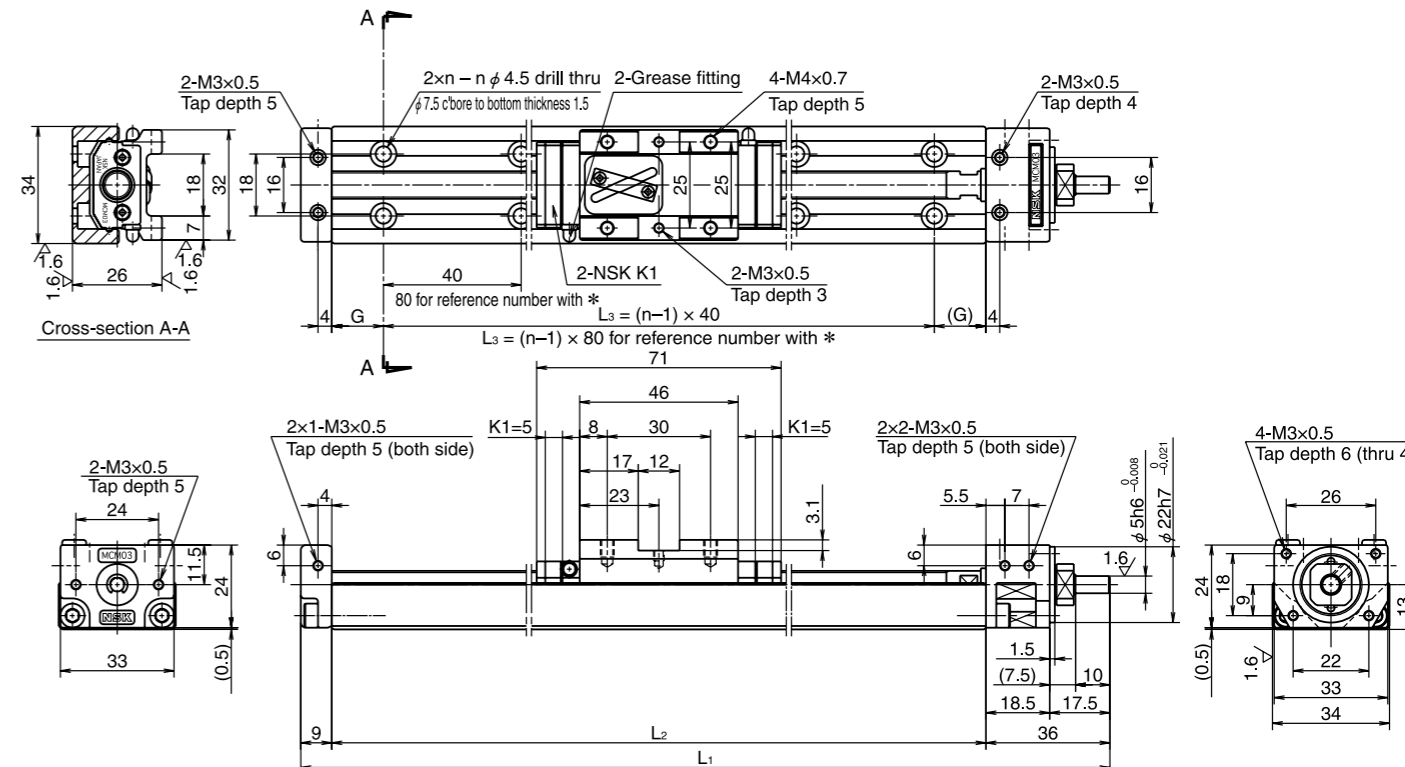

Dimension of MCM03 (Single slider)

Reference No.	Nominal stroke (mm)	Stroke limit (mm) (without K1)	Ball screw lead (mm)	Body length (mm)				No. of mounting hole <i>n</i>	Inertia $\times 10^{-5}$ (kg · m ²)	Mass (kg)	
				L ₁	L ₂	G	L ₃				
*MCM03005H05K00	50	69 (79)	5	185	140	30	80	2	0.057	0.6	
*MCM03005H10K00			10								0.080
*MCM03005H12K00			12								0.097
MCM03010H05K00	100	119 (129)	5	235	190	15	160	5	0.073	0.7	
MCM03010H10K00			10								0.092
MCM03010H12K00			12								0.109
MCM03015H05K00	150	169 (179)	5	285	240	20	200	6	0.089	0.8	
MCM03015H10K00			10								0.105
MCM03015H12K00			12								0.122
MCM03020H05K00	200	219 (229)	5	335	290	25	240	7	0.104	0.9	
MCM03020H10K00			10								0.118
MCM03020H12K00			12								0.135
MCM03025H05K00	250	269 (279)	5	385	340	30	280	8	0.120	1.0	
MCM03025H10K00			10								0.131
MCM03025H12K00			12								0.147

Note: Bolt hole pitch L₃ on items marked with * is 80 mm.

Monocarrier dynamic torque specification (N · cm)

Ball screw lead (mm)	5	0.2 – 2.5
	10	
	12	0.3 – 3.0

Notes:

- Frictional resistance of NSK K1 is included in dynamic torque in table.
- Grease is packed into ball screw, linear guide parts and support unit.
- Consult NSK for life estimates under large moment loads.

Basic load rating

Lead <i>l</i> (mm)	Shaft dia <i>d</i> (mm)	Basic dynamic load rating (N)				Basic static load rating (N)			Support unit load limit (N)
		Ball screw <i>C_a</i>	Linear guides <i>C</i>	Support unit <i>C_a</i>	Rated running distance <i>L_a</i> (km)	Ball screw <i>C_{0a}</i>	Linear guides <i>C₀</i>	Support unit	
5	φ8	1 810	7 850	2 670	5	2 880	6 620	1 040	
10		1 230	6 250						
12			5 880						

Basic static moment load of linear guide

Slider	Basic static moment load (N · m)		
	Rolling M _{RO}	Pitching M _{PO}	Yawing M _{YO}
Single	92	51	51

MCM03

Ball screw lead 15

Accuracy grade: High grade (H)

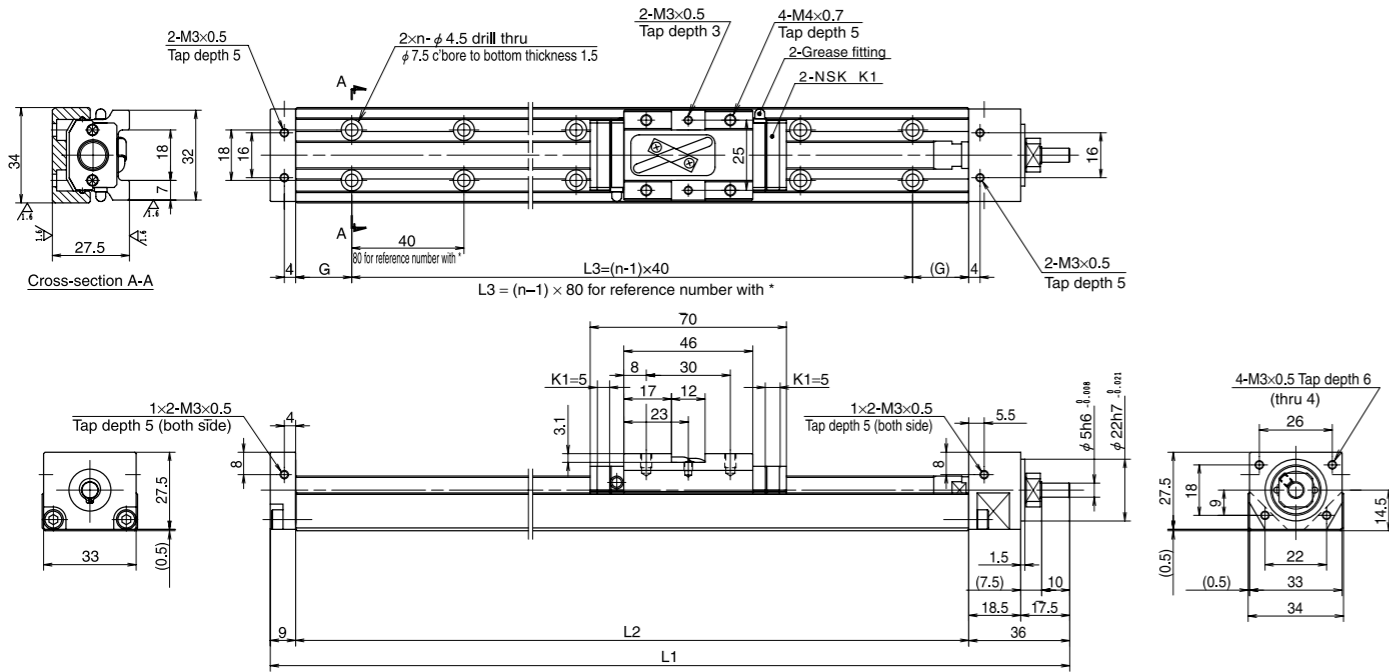

Dimension of MCM03 (Single slider)

Reference No.	Nominal stroke (mm)	Stroke limit (without K1)	Ball screw lead (mm)	Ball screw diameter (mm)	Body length (mm)				No. of mounting hole <i>n</i>	Inertia ×10 ⁻⁴ (kg·m ²)	Mass (kg)
					L ₁	L ₂	G	L ₃			
* MCM03005H15K00	50	70 (80)			185	140	30	80	2	0.183	0.67
MCM03010H15K00	100	120(130)			235	190	15	160	5	0.222	0.77
MCM03015H15K00	150	170(180)	15	φ 10	285	240	20	200	6	0.260	0.87
MCM03020H15K00	200	220(230)			335	290	25	240	7	0.298	0.97
MCM03025H15K00	250	270(280)			385	340	30	280	8	0.336	1.07

Note: Bolt hole pitch L₃ on items marked with * is 80 mm.

Monocarrier dynamic torque specification (N · cm)

Ball screw lead (mm)	15	0.3 – 5.6
----------------------	----	-----------

Notes:

1. Frictional resistance of NSK K1 is included in dynamic torque in table.
2. Grease is packed into ball screw, linear guide parts and support unit.
3. Consult NSK for life estimates under large moment loads.
4. When a cover unit is added, an optional spacer plate is required. (See page 51.)

Basic load rating

Lead <i>l</i> (mm)	Shaft dia <i>d</i> (mm)	Basic dynamic load rating (N)				Basic static load rating (N)		Support unit load limit (N)
		Ball screw <i>C_s</i>	Linear guides <i>C</i>	Support unit <i>C_a</i>	Rated running distance <i>L_s</i> (km)	Ball screw <i>C_{0s}</i>	Linear guide <i>C₀</i>	
15	φ 10	1 760	5 440	2 670	15	2 680	6 620	1 040

Basic static load of linear guide

Slider	Basic static moment load (N · m)		
	Rolling <i>M_{RO}</i>	Pitching <i>M_{PO}</i>	Yawing <i>M_{YO}</i>
Single	92	51	51

MCM05

Accuracy grade: High grade (H)

Ball screw lead 5, 10 and 20

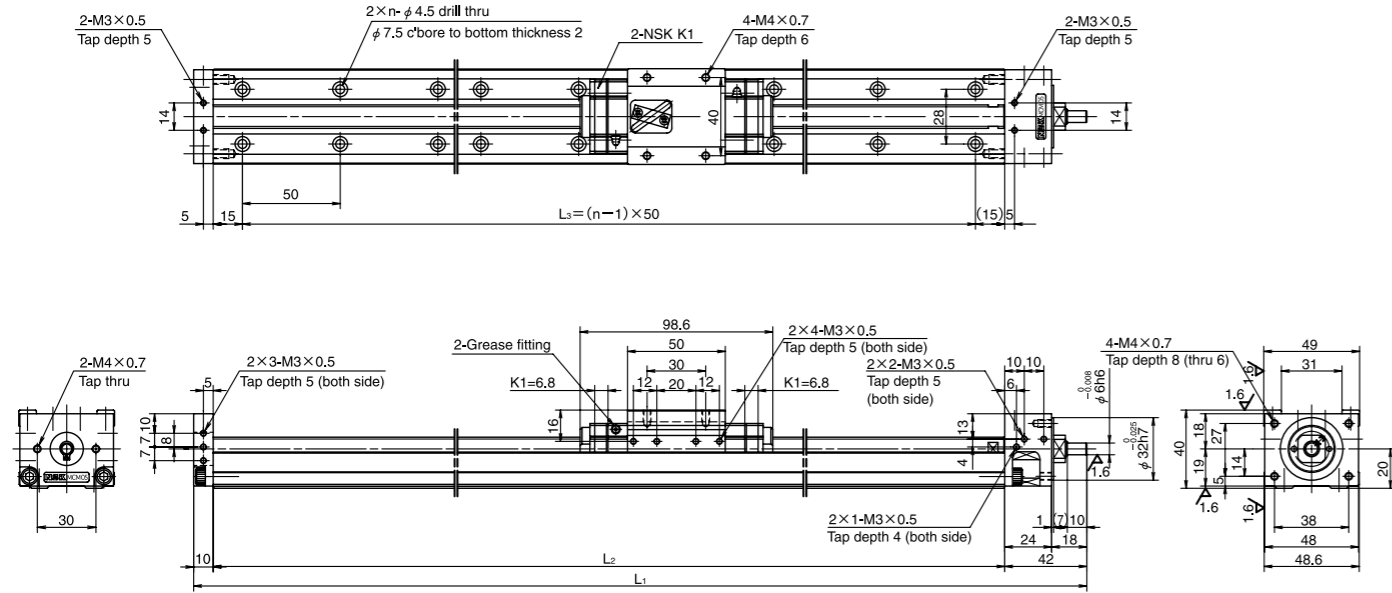

Dimension of MCM05 (Single slider)

Reference No.	Nominal stroke (mm)	Stroke limit (mm) (without K1)	Ball screw lead (mm)	Body length (mm)			No. of mounting hole <i>n</i>	Inertia $\times 10^{-4}$ (kg · m ²)	Mass (kg)
				L ₁	L ₂	L ₃			
MCM05005H05K00	50	81 (95)	5	232	180	150	4	0.025	1.4
MCM05005H10K00			10					0.035	
MCM05005H20K00			20					0.073	
MCM05010H05K00	100	131 (145)	5	282	230	200	5	0.031	1.6
MCM05010H10K00			10					0.040	
MCM05010H20K00			20					0.078	
MCM05015H05K00	150	181 (195)	5	332	280	250	6	0.036	1.8
MCM05015H10K00			10					0.046	
MCM05015H20K00			20					0.084	
MCM05020H05K00	200	231 (245)	5	382	330	300	7	0.042	2.0
MCM05020H10K00			10					0.051	
MCM05020H20K00			20					0.089	
MCM05025H05K00	250	281 (295)	5	432	380	350	8	0.047	2.2
MCM05025H10K00			10					0.057	
MCM05025H20K00			20					0.095	

Monocarrier dynamic torque specification (N · cm)

Ball screw lead (mm)	5	1.0 – 4.8
	10	1.1 – 5.8
	20	1.6 – 7.9
	30	1.8 – 11.1

Notes:

- Frictional resistance of NSK K1 is included in dynamic torque in table.
- Grease is packed into ball screw, linear guide parts and support unit.
- Consult NSK for life estimates under large moment loads.

Basic load rating

Lead <i>l</i> (mm)	Shaft dia <i>d</i> (mm)	Basic dynamic load rating (N)				Basic static load rating (N)		Support unit load limit (N)	
		Ball screw <i>C_a</i>	Linear guides <i>C</i>	Support unit <i>C_a</i>	Rated running distance <i>L_a</i> (km)	Ball screw <i>C_{0a}</i>	Linear guides <i>C₀</i>		
5	φ 12	3 760	15 600	4 400	5	6 310	10 900	1 450	
10		2 420	12 400		10				3 790
20		2 420	9 850		20				3 790
30		3 260	8 600		30				5 400

Basic static moment load of linear guide

Slider	Basic static moment load (N · m)		
	Rolling <i>M_{RO}</i>	Pitching <i>M_{PO}</i>	Yawing <i>M_{YO}</i>
Single	229	89	89

MCM05

Accuracy grade: High grade (H)

Ball screw lead 30

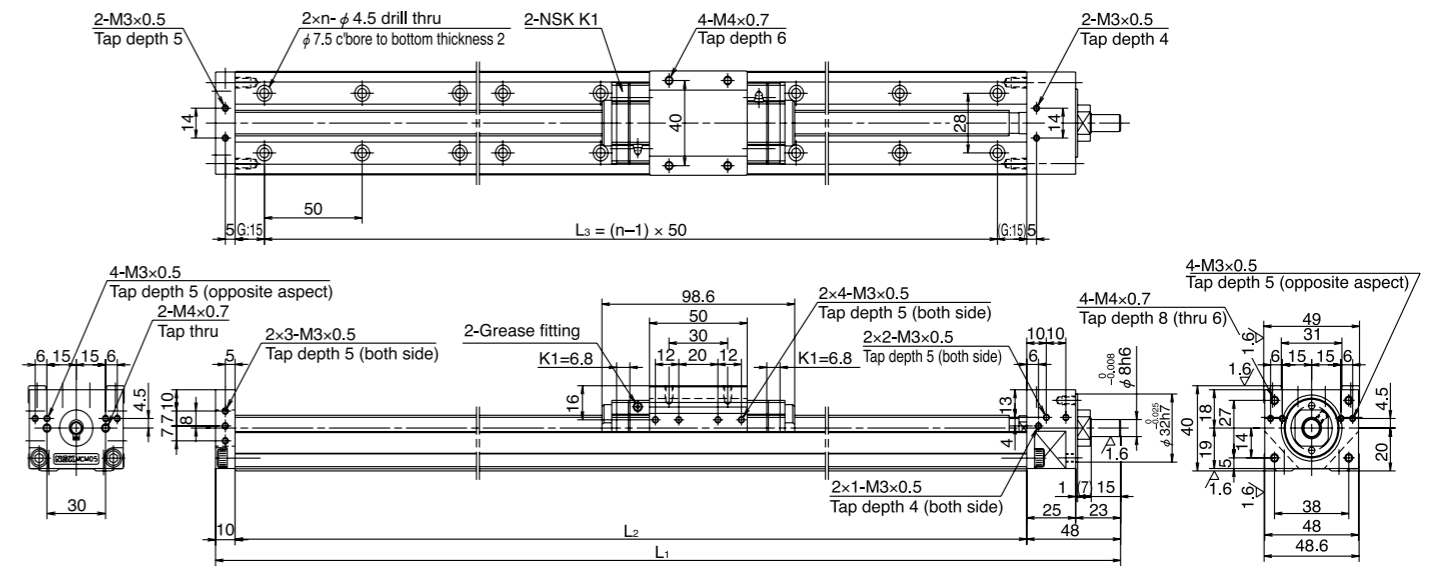

Dimension of MCM05 (Single slider)

Reference No.	Nominal stroke (mm)	Stroke limit (mm) (without K1)	Ball screw lead (mm)	Body length (mm)			No. of mounting hole <i>n</i>	Inertia $\times 10^{-4}$ (kg · m ²)	Mass (kg)
				L ₁	L ₂	L ₃			
MCM05030H05K00	300	331 (345)	5	482	430	400	9	0.053	2.3
MCM05030H10K00			10					0.063	
MCM05030H20K00			20					0.101	
MCM05030H30K00	400	431 (445)	30	488	530	500	11	0.164	2.7
MCM05040H05K00			5					0.064	
MCM05040H10K00			10					0.074	
MCM05040H20K00	500	531 (545)	20	582	630	600	13	0.112	3.1
MCM05050H05K00			5					0.076	
MCM05050H10K00			10					0.085	
MCM05050H20K00	600	631 (645)	20	682	730	700	15	0.123	3.5
MCM05050H30K00			30					0.186	
MCM05060H05K00			5					0.087	
MCM05060H10K00	600	631 (645)	10	782	730	700	15	0.096	3.5
MCM05060H20K00			20					0.134	
MCM05060H30K00			30					0.198	

Monocarrier dynamic torque specification (N · cm)

Ball screw lead (mm)	5	1.0 – 4.8
	10	1.1 – 5.8
	20	1.6 – 7.9
	30	1.8 – 11.1

Notes:

- Frictional resistance of NSK K1 is included in dynamic torque in table.
- Grease is packed into ball screw, linear guide parts and support unit.
- Consult NSK for life estimates under large moment loads.

Basic load rating

Lead <i>l</i> (mm)	Shaft dia <i>d</i> (mm)	Basic dynamic load rating (N)				Basic static load rating (N)		Support unit load limit (N)	
		Ball screw <i>C_a</i>	Linear guides <i>C</i>	Support unit <i>C_a</i>	Rated running distance <i>L_a</i> (km)	Ball screw <i>C_{0a}</i>	Linear guides <i>C₀</i>		
5	φ 12	3 760	15 600	4 400	5	6 310	10 900	1 450	
10		2 420	12 400		10				3 790
20		2 420	9 850		20				3 790
30		3 260	8 600		30				5 400

Basic static moment load of linear guide

Slider	Basic static moment load (N · m)		
	Rolling <i>M_{RO}</i>	Pitching <i>M_{PO}</i>	Yawing <i>M_{YO}</i>
Single	229	89	89

MCM05 (Double slider)

Accuracy grade: High grade (H)

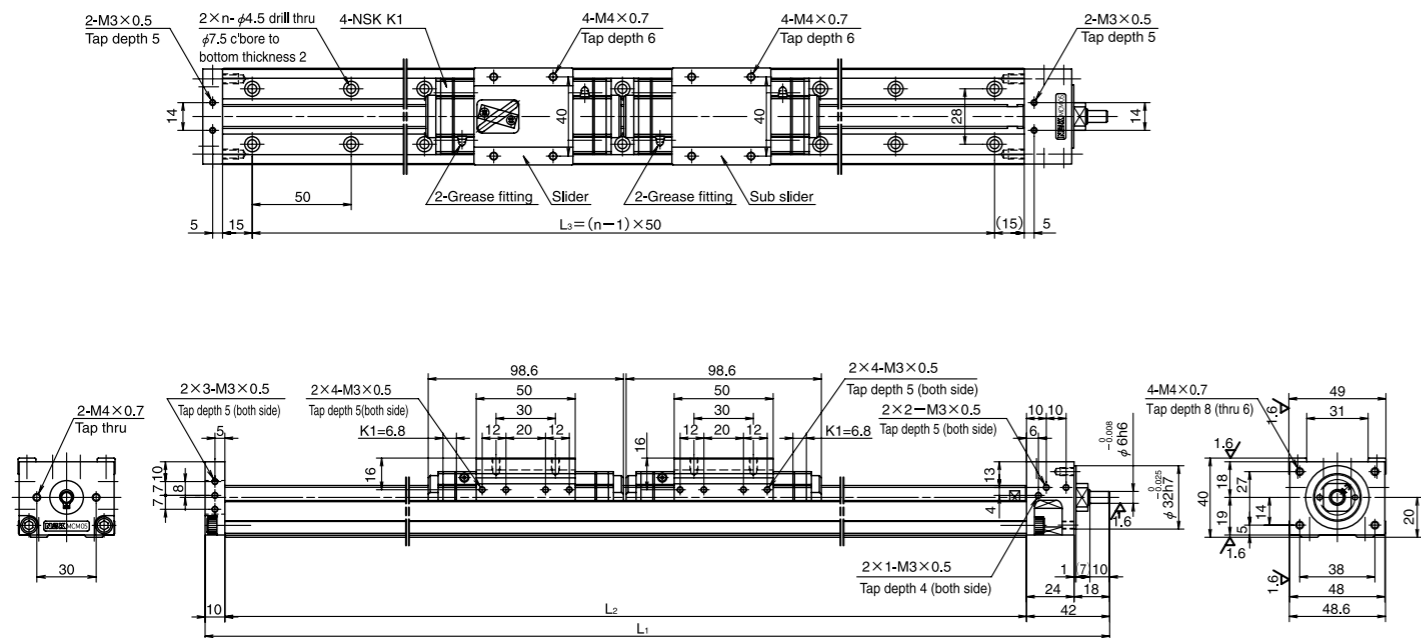

MCM05 (Double slider)

Accuracy grade: High grade (H)

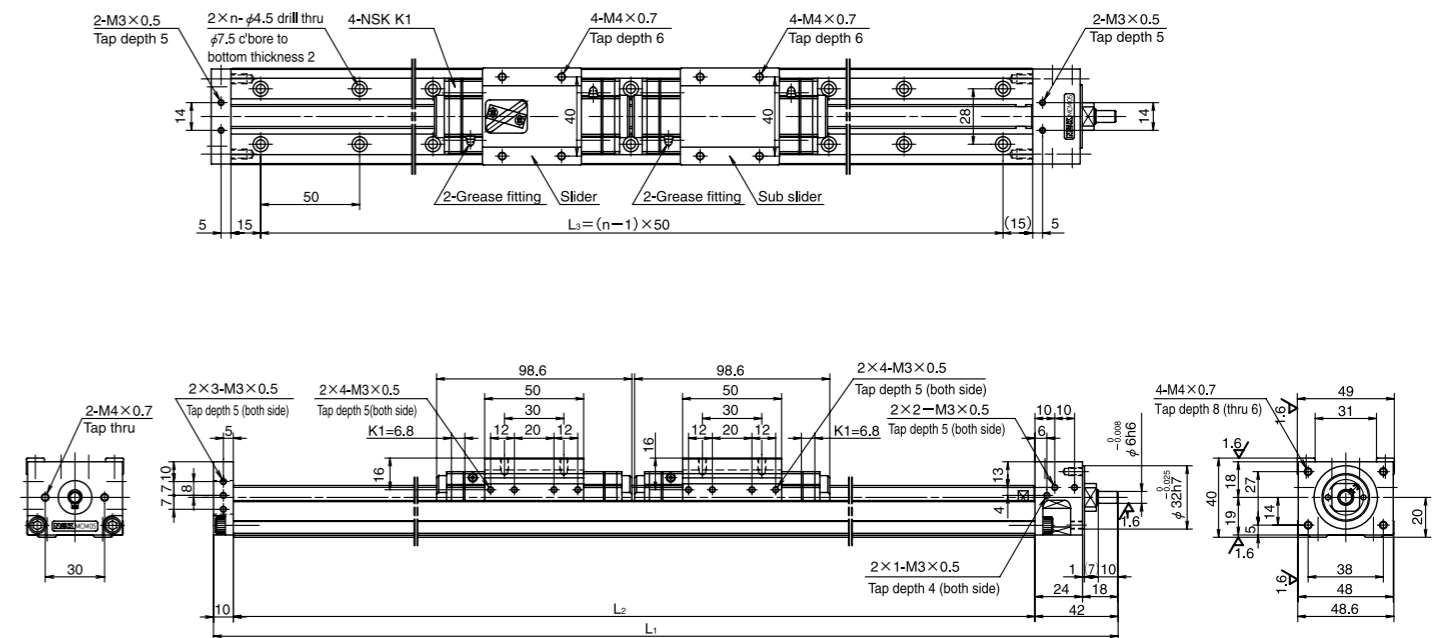

Dimension of MCM05 (Double slider)

Reference No.	Nominal stroke (mm)	Stroke limit (mm) (without K1)	Ball screw lead (mm)	Body length (mm)			No. of mounting hole n	Inertia × 10 ⁻⁴ (kg · m ²)	Mass (kg)
				L ₁	L ₂	L ₃			
MCM05006H10D00	60	82 (110)	10	332	280	250	6	0.058	2.3
MCM05011H10D00	110	132 (160)	10	382	330	300	7	0.064	2.5
MCM05016H10D00	160	182 (210)	10	432	380	350	8	0.070	2.7
MCM05021H10D00	210	232	10	482	430	400	9	0.075	2.8
MCM05021H20D00		(260)	20						

Dimension of MCM05 (Double slider)

Reference No.	Nominal stroke (mm)	Stroke limit (mm) (without K1)	Ball screw lead (mm)	Body length (mm)			No. of mounting hole n	Inertia × 10 ⁻⁴ (kg · m ²)	Mass (kg)
				L ₁	L ₂	L ₃			
MCM05031H10D00	310	332 (360)	10	582	530	500	11	0.086	3.2
MCM05031H20D00		(460)	20						
MCM05041H10D00	410	432 (460)	10	682	630	600	13	0.098	3.6
MCM05041H20D00		(560)	20						
MCM05051H10D00	510	532 (560)	10	782	730	700	15	0.109	4.2
MCM05051H20D00		(660)	20						

Monocarrier dynamic torque specification (N · cm)

Ball screw lead (mm)	10		1.5 – 7.6	
	20		2.3 – 11.8	

Notes:

- Frictional resistance of NSK K1 is included in dynamic torque in table.
- Grease is packed into ball screw, linear guide parts and support unit.
- Consult NSK for life estimates under large moment loads.

Monocarrier dynamic torque specification (N · cm)

Ball screw lead (mm)	10		1.5 – 7.6	
	20		2.3 – 11.8	

Notes:

- Frictional resistance of NSK K1 is included in dynamic torque in table.
- Grease is packed into ball screw, linear guide parts and support unit.
- Consult NSK for life estimates under large moment loads.

Basic load rating

Lead l (mm)	Shaft dia d (mm)	Basic dynamic load rating (N)				Basic static load rating (N)			Support unit load limit (N)
		Ball screw C _a	Linear guides C	Support unit C _a	Rated running distance L _a (km)	Ball screw C _{0a}	Linear guides C ₀	Support unit C ₀	
5	φ 12	3 760	15 600	4 400	5	6 310	10 900	1 450	
10		2 420	12 400		10				3 790
20		2 420	9 850		20				3 790

Basic static moment load of linear guide

Slider	Basic static moment load (N · m)		
	Rolling M _{RO}	Pitching M _{PO}	Yawing M _{YO}
Double	455	765	765

Basic load rating

Lead l (mm)	Shaft dia d (mm)	Basic dynamic load rating (N)				Basic static load rating (N)			Support unit load limit (N)
		Ball screw C _a	Linear guides C	Support unit C _a	Rated running distance L _a (km)	Ball screw C _{0a}	Linear guides C ₀	Support unit C ₀	
5	φ 12	3 760	15 600	4 400	5	6 310	10 900	1 450	
10		2 420	12 400		10				3 790
20		2 420	9 850		20				3 790

Basic static moment load of linear guide

Slider	Basic static moment load (N · m)		
	Rolling M _{RO}	Pitching M _{PO}	Yawing M _{YO}
Double	455	765	765

MCM08

Accuracy grade: High grade (H)

Ball screw lead 5, 10 and 20

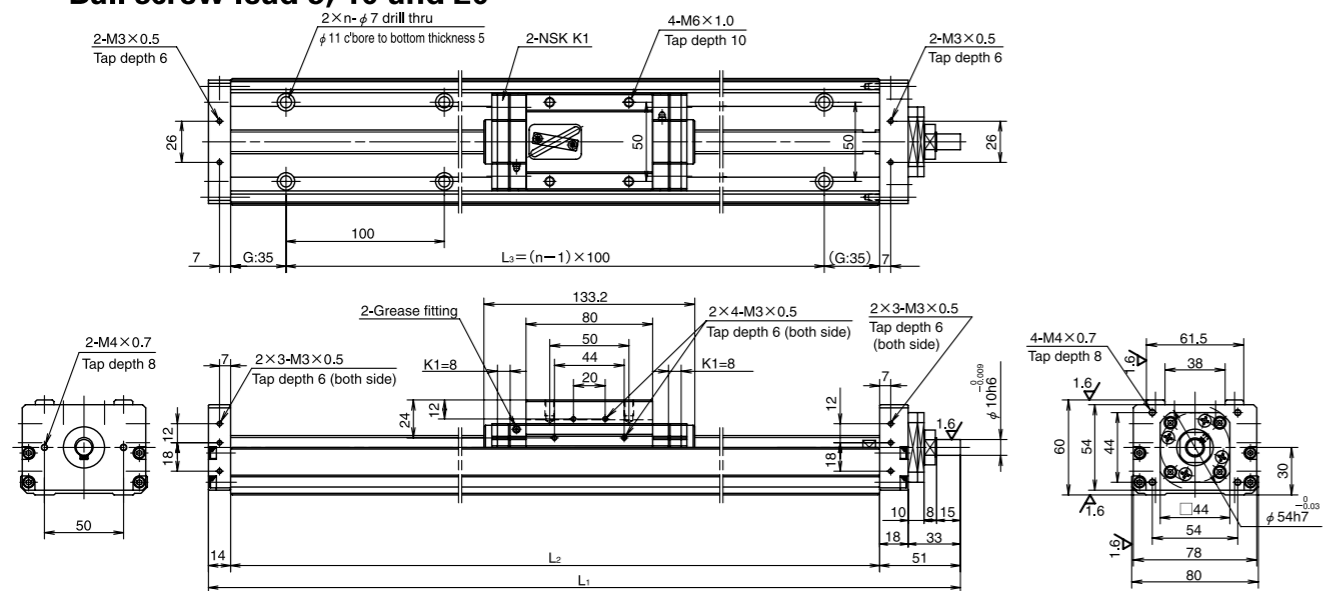

Dimension of MCM08 (Single slider)

Reference No.	Nominal stroke (mm)	Stroke limit (mm) (without K1)	Ball screw lead (mm)	Body length (mm)			No. of mounting hole <i>n</i>	Inertia $\times 10^{-4}$ (kg · m ²)	Mass (kg)
				L ₁	L ₂	L ₃			
◇MCM08005H05K02	50	86 (102)	5	285	220	100	2	0.082	4.1
◇MCM08005H10K00			10					0.100	
MCM08010H05K02	100	136 (152)	5	335	270	200	3	0.097	4.6
MCM08010H10K00			10					0.114	
MCM08010H20K00			20					0.190	
◇MCM08015H05K02			5					0.111	
◇MCM08015H10K00	150	186 (202)	10	385	320	200	3	0.129	5.1
◇MCM08015H20K00			20					0.205	
MCM08020H05K02			5					0.126	
MCM08020H10K00	200	236 (252)	10	435	370	300	4	0.144	5.5
MCM08020H20K00			20					0.220	
◇MCM08025H05K02			5					0.141	
◇MCM08025H10K00	250	286 (302)	10	485	420	300	4	0.159	6.0
◇MCM08025H20K00			20					0.235	
MCM08030H05K02			5					0.156	
MCM08030H10K00	300	336 (352)	10	535	470	400	5	0.173	6.5
MCM08030H20K00			20					0.249	

Notes: 1. Dimension G is 60 for items marked with ◇.
2. The nominal number in the above table is for high-grade grease specifications. In the case of other specifications, see the following table for the 13th and 14th digits.

Coding for columns 13 and 14

Grease	Lead	High-grade, precision-grade
Standard	5	02
	10, 20	00
LG2	5	B2
	10, 20	B0

Ball screw lead (mm)	Monocarrier dynamic torque specification (N · cm)	
	5	1.0 – 5.9
	10	2.0 – 7.8
	20	2.5 – 10.8
30	2.8 – 12.0	

Notes:
1. Frictional resistance of NSK K1 is included in dynamic torque in table.
2. Grease is packed into ball screw, linear guide parts and support unit.
3. Consult NSK for life estimates under large moment loads.

Basic load rating

Lead <i>l</i> (mm)	Shaft dia <i>d</i> (mm)	Basic dynamic load rating (N)				Basic static load rating (N)		Support unit load limit (N)	
		Ball screw <i>C_a</i>	Linear guides <i>C</i>	Support unit <i>C_a</i>	Rated running distance <i>L_a</i> (km)	Ball screw <i>C_{0a}</i>	Linear guides <i>C₀</i>		
5	φ 15	7 070	30 800	7 100	5	12 800	22 800	3 040	
10		7 070	24 400		10				12 800
20		4 560	19 400		20				7 730
30		5 070	16 930		30				8 730

Basic static moment load of linear guide

Slider	Basic static moment load (N · m)		
	Rolling M _{RO}	Pitching M _{PO}	Yawing M _{YO}
Single	770	300	300

MCM08

Accuracy grade: High grade (H)

Ball screw lead 30

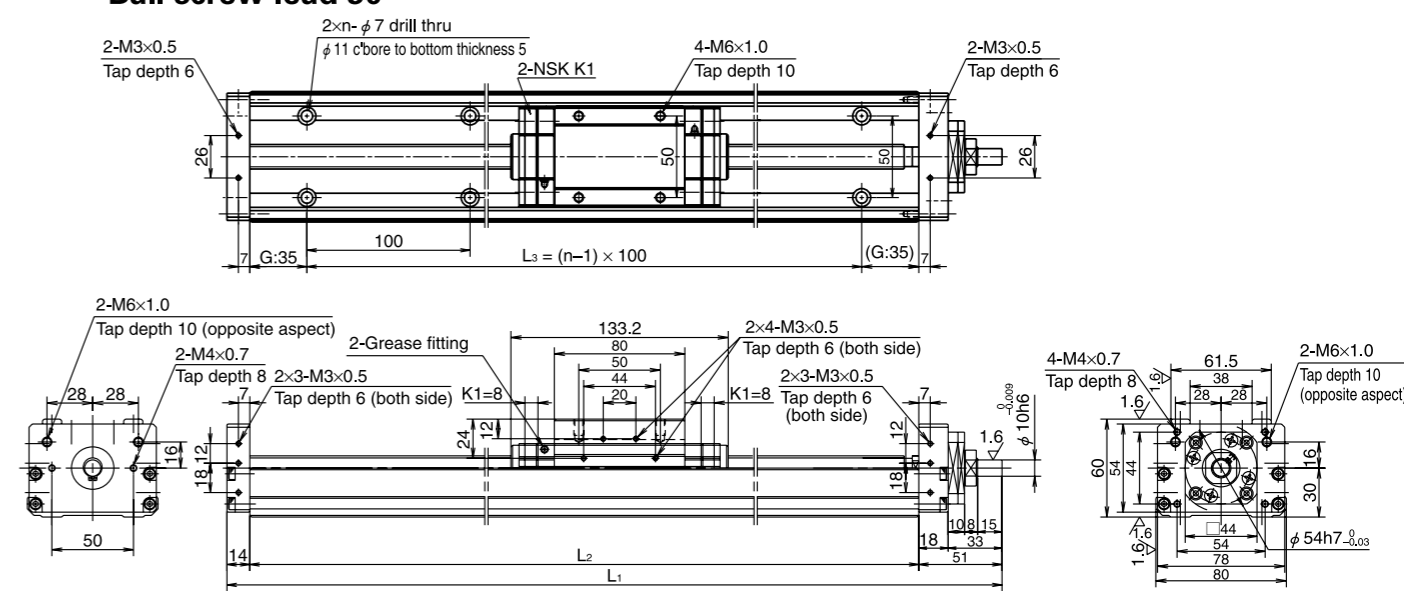

Dimension of MCM08 (Single slider)

Reference No.	Nominal stroke (mm)	Stroke limit (mm) (without K1)	Ball screw lead (mm)	Body length (mm)			No. of mounting hole <i>n</i>	Inertia $\times 10^{-4}$ (kg · m ²)	Mass (kg)
				L ₁	L ₂	L ₃			
MCM08040H05K02	400	436 (452)	5	635	570	500	6	0.185	7.4
MCM08040H10K00			10					0.203	
MCM08040H20K00			20					0.279	
MCM08040H30K00			30					0.405	
MCM08050H05K02	500	536 (552)	5	735	670	600	7	0.214	8.4
MCM08050H10K00			10					0.232	
MCM08050H20K00			20					0.308	
MCM08050H30K00			30					0.435	
MCM08060H05K02	600	636 (652)	5	835	770	700	8	0.244	9.3
MCM08060H10K00			10					0.262	
MCM08060H20K00			20					0.338	
MCM08060H30K00			30					0.464	
MCM08070H05K02	700	736 (752)	5	935	870	800	9	0.273	10.5
MCM08070H10K00			10					0.291	
MCM08070H20K00			20					0.367	
MCM08070H30K00			30					0.494	
MCM08080H05K02	800	836 (852)	5	1 035	970	900	10	0.303	11.2
MCM08080H10K00			10					0.320	
MCM08080H20K00			20					0.396	

Note: The nominal number in the above table is for high-grade grease specifications. In the case of other specifications, see the following table for the 13th and 14th digits.

Coding for columns 13 and 14

Grease	Lead	High-grade, precision-grade
Standard	5	02
	10, 20	00
LG2	5	B2
	10, 20	B0

Ball screw lead (mm)	Monocarrier dynamic torque specification (N · cm)	
	5	1.0 – 5.9
	10	2.0 – 7.8
	20	2.5 – 10.8
30	2.8 – 12.0	

Notes:
1. Frictional resistance of NSK K1 is included in dynamic torque in table.
2. Grease is packed into ball screw, linear guide parts and support unit.
3. Consult NSK for life estimates under large moment loads.

Basic load rating

Lead <i>l</i> (mm)	Shaft dia <i>d</i> (mm)	Basic dynamic load rating (N)				Basic static load rating (N)		Support unit load limit (N)	
		Ball screw <i>C_a</i>	Linear guides <i>C</i>	Support unit <i>C_a</i>	Rated running distance <i>L_a</i> (km)	Ball screw <i>C_{0a}</i>	Linear guides <i>C₀</i>		
5	φ 15	7 070	30 800	7 100	5	12 800	22 800	3 040	
10		7 070	24 400		10				12 800
20		4 560	19 400		20				7 730
20		4 560	19 400		20				7 730
30		5 070	16 930		30				8 730

Basic static moment load of linear guide

Slider	Basic static moment load (N · m)		
	Rolling M _{RO}	Pitching M _{PO}	Yawing M _{YO}
Single	770	300	300

MCM08 (Double slider)

Accuracy grade: High grade (H)

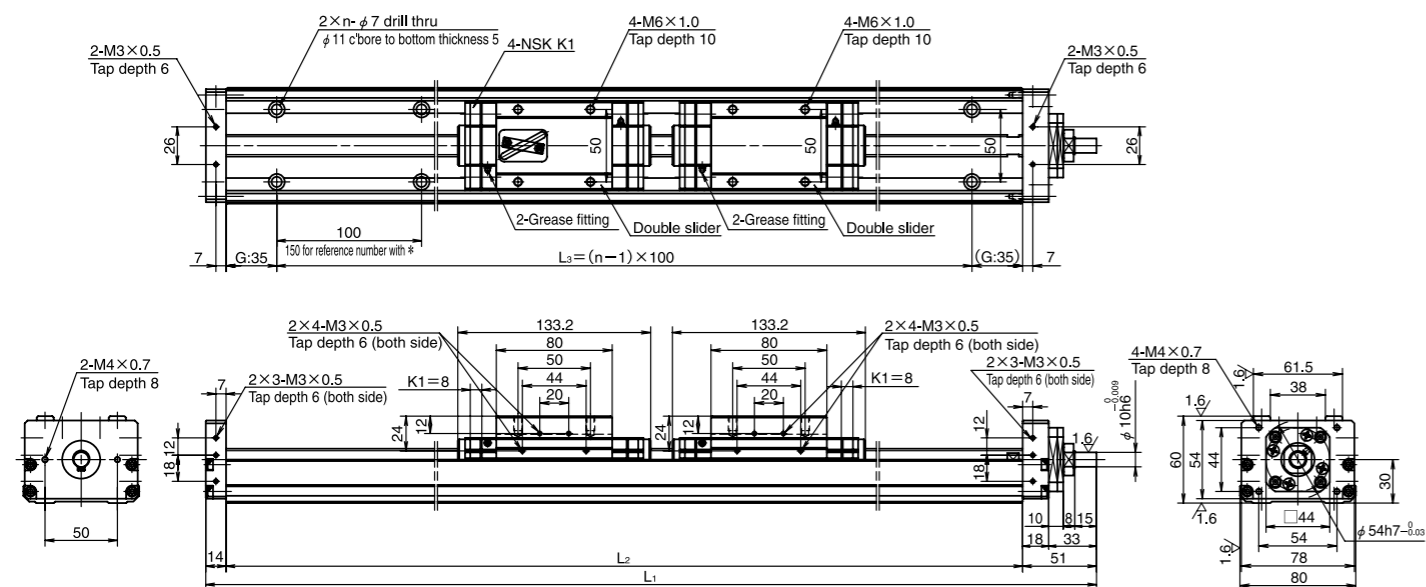

Dimension of MCM08 (Double slider)

Reference No.	Nominal stroke (mm)	Stroke limit (mm) (without K1)	Ball screw lead (mm)	Body length (mm)			No. of mounting hole n	Inertia × 10 ⁻⁴ (kg · m ²)	Mass (kg)
				L ₁	L ₂	L ₃			
*MCM08008H10D00	80	103 (135)	10	435	370	300	3	0.169	6.5
MCM08018H10D00	180	203 (235)	10	535	470	400	5	0.199	7.5
MCM08018H20D00			20						
MCM08028H10D00	280	303 (335)	10	635	570	500	6	0.228	8.4
MCM08028H20D00			20						
MCM08038H10D00	380	403 (435)	10	735	670	600	7	0.257	9.4
MCM08038H20D00			20						

Note: Bolt hole pitch L3 on item marked with * is 150 mm.

Monocarrier dynamic torque specification (N · cm)

Ball screw lead (mm)	Torque (N · cm)	
	10	20
10	2.5 – 10.8	4.0 – 17.2
20	4.0 – 17.2	4.0 – 17.2

Notes:

- Frictional resistance of NSK K1 is included in dynamic torque in table.
- Grease is packed into ball screw, linear guide parts and support unit.
- Consult NSK for life estimates under large moment loads.

Basic load rating

Lead l (mm)	Shaft dia d (mm)	Basic dynamic load rating (N)				Basic static load rating (N)		Support unit load limit (N)
		Ball screw C _a	Linear guides C	Support unit C _a	Rated running distance L _a (km)	Ball screw C _{0a}	Linear guides C ₀	
10	φ15	7 070	24 400	7 100	10	12 800	22 800	3 040
20		4 560	19 400		20	7 730		

Basic static moment load of linear guide

Slider	Basic static moment load (N · m)		
	Rolling M _{RO}	Pitching M _{PO}	Yawing M _{YO}
Double	1 540	2 050	2 050

MCM08 (Double slider)

Accuracy grade: High grade (H)

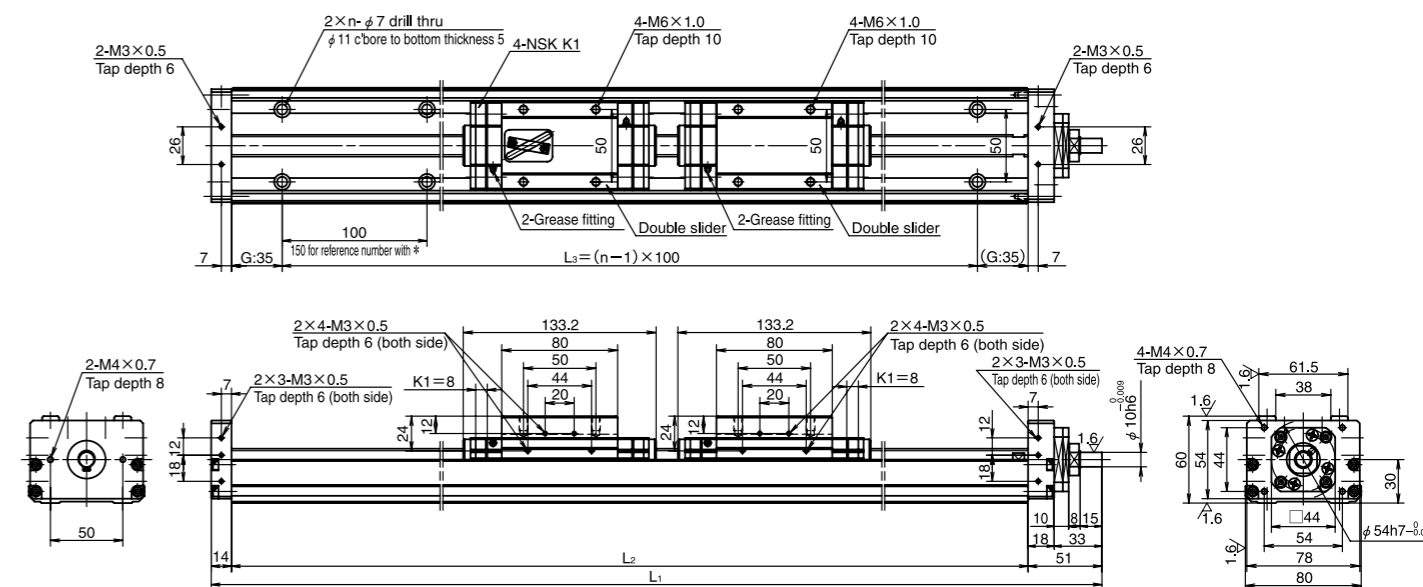

Dimension of MCM08 (Double slider)

Reference No.	Nominal stroke (mm)	Stroke limit (mm) (without K1)	Ball screw lead (mm)	Body length (mm)			No. of mounting hole n	Inertia × 10 ⁻⁴ (kg · m ²)	Mass (kg)
				L ₁	L ₂	L ₃			
MCM08048H10D00	480	503 (535)	10	835	770	700	8	0.287	10.3
MCM08048H20D00			20						
MCM08058H10D00	580	603 (635)	10	935	870	800	9	0.316	11.5
MCM08058H20D00			20						
MCM08068H10D00	680	703 (735)	10	1 035	970	900	10	0.346	12.2
MCM08068H20D00			20						

Monocarrier dynamic torque specification (N · cm)

Ball screw lead (mm)	Torque (N · cm)	
	10	20
10	2.5 – 10.8	4.0 – 17.2
20	4.0 – 17.2	4.0 – 17.2

Notes:

- Frictional resistance of NSK K1 is included in dynamic torque in table.
- Grease is packed into ball screw, linear guide parts and support unit.
- Consult NSK for life estimates under large moment loads.

Basic load rating

Lead l (mm)	Shaft dia d (mm)	Basic dynamic load rating (N)				Basic static load rating (N)		Support unit load limit (N)
		Ball screw C _a	Linear guides C	Support unit C _a	Rated running distance L _a (km)	Ball screw C _{0a}	Linear guides C ₀	
10	φ15	7 070	24 400	7 100	10	12 800	22 800	3 040
20		4 560	19 400		20	7 730		

Basic static moment load of linear guide

Slider	Basic static moment load (N · m)		
	Rolling M _{RO}	Pitching M _{PO}	Yawing M _{YO}
Double	1 540	2 050	2 050

MCM10

Accuracy grade: High grade (H)

Ball screw lead 10 and 20

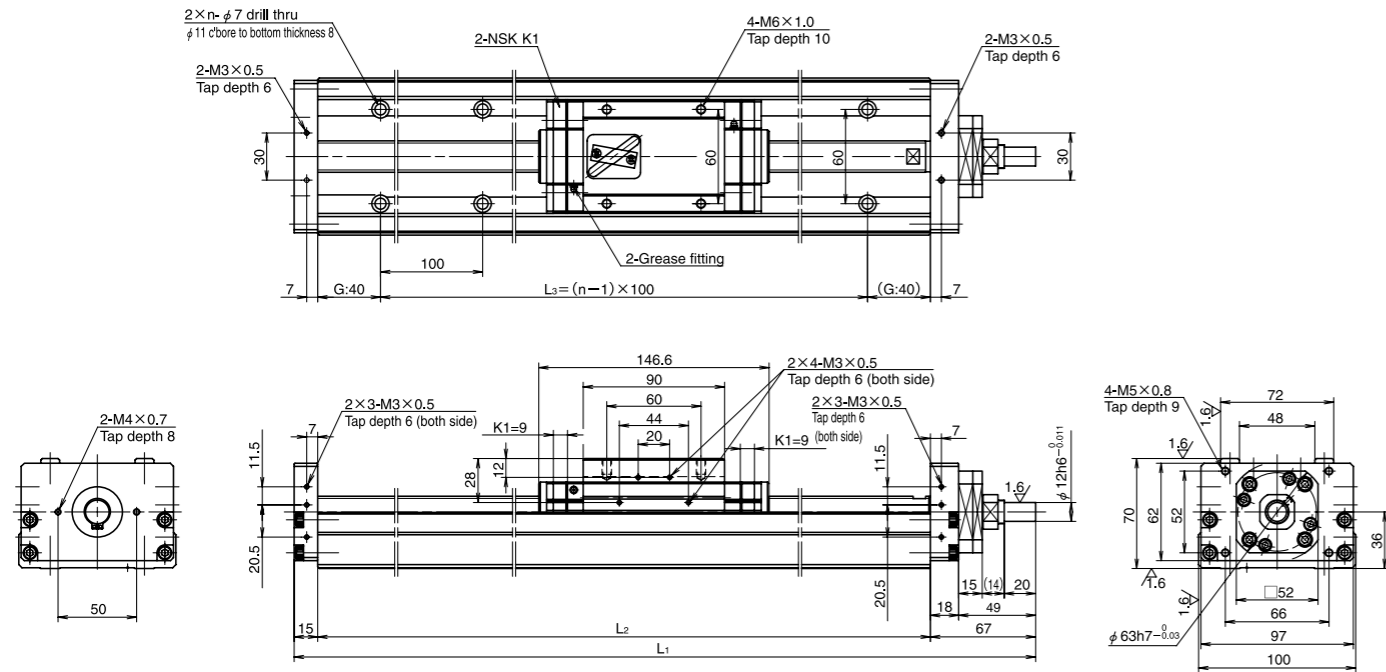

Dimension of MCM10 (Single slider)

Reference No.	Nominal stroke (mm)	Stroke limit (mm) (without K1)	Ball screw lead (mm)	Body length (mm)			No. of mounting hole <i>n</i>	Inertia $\times 10^{-4}$ (kg · m ²)	Mass (kg)
				L ₁	L ₂	L ₃			
MCM10010H10K00	100	133	10	362	280	200	2*	0.332	7.8
MCM10010H20K00		(151)	20					0.446	
◇MCM10015H10K00	150	183	10	412	330	300	4	0.378	8.7
◇MCM10015H20K00		(201)	20					0.492	
MCM10020H10K00	200	233	10	462	380	300	4	0.425	9.5
MCM10020H20K00		(251)	20					0.539	
◇MCM10025H10K00	250	283	10	512	430	400	5	0.472	10.4
◇MCM10025H20K00		(301)	20					0.586	
MCM10030H10K00	300	333	10	562	480	400	5	0.519	11.2
MCM10030H20K00		(351)	20					0.633	
MCM10040H10K00	400	433	10	662	580	500	6	0.612	13.0
MCM10040H20K00		(451)	20					0.726	
MCM10050H10K00	500	533 (551)	10	762	680	600	7	0.706	14.6
MCM10050H20K00			20					0.820	
MCM10050H30K00			30					1.010	

Notes: 1. Dimension G is 15 for items marked with ◇.
2. *: Use mounting holes on each end of the rail.

Monocarrier dynamic torque specification (N · cm)

Ball screw lead (mm)	Notes:	
	10	2.7 – 10.8
	20	3.1 – 12.7
30	5.1 – 18.0	

Notes:
1. Frictional resistance of NSK K1 is included in dynamic torque in table.
2. Grease is packed into ball screw, linear guide parts and support unit.
3. Consult NSK for life estimates under large moment loads.

Basic load rating

Lead <i>l</i> (mm)	Shaft dia <i>d</i> (mm)	Basic dynamic load rating (N)				Basic static load rating (N)		Support unit load limit (N)
		Ball screw <i>C_a</i>	Linear guides <i>C</i>	Support unit <i>C_a</i>	Rated running distance <i>L_a</i> (km)	Ball screw <i>C_{0a}</i>	Linear guides <i>C₀</i>	
10	φ 20	11 000	33 500	7 600	10	21 100	29 400	3 380
20		7 060	26 600		20	12 700		
30		11 700	23 200		30	22 700		

Basic static moment load of linear guide

Slider	Basic static moment load (N · m)		
	Rolling <i>M_{RO}</i>	Pitching <i>M_{PO}</i>	Yawing <i>M_{YO}</i>
Single	1 170	425	425

MCM10

Accuracy grade: High grade (H)

Ball screw lead 30

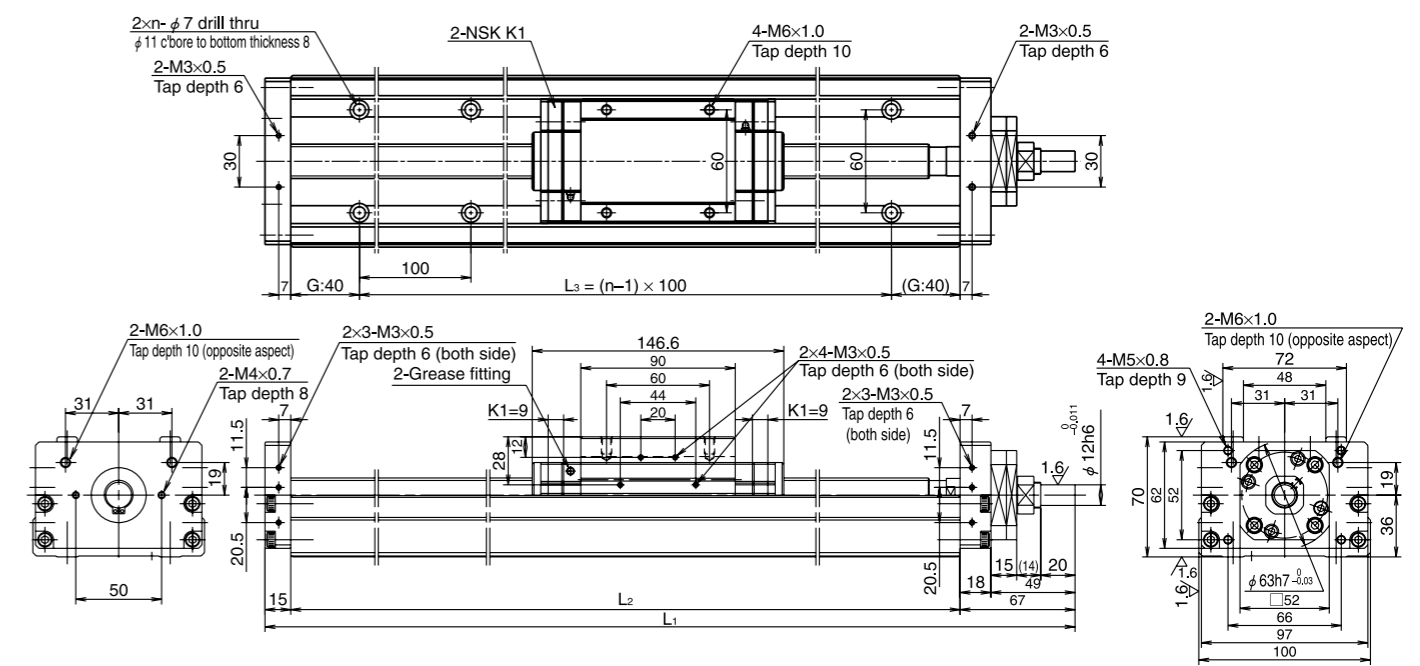

Dimension of MCM10 (Single slider)

Reference No.	Nominal stroke (mm)	Stroke limit (mm) (without K1)	Ball screw lead (mm)	Body length (mm)			No. of mounting hole <i>n</i>	Inertia $\times 10^{-4}$ (kg · m ²)	Mass (kg)
				L ₁	L ₂	L ₃			
MCM10060H10K00	600	633 (651)	10	862	780	700	8	0.800	16.3
MCM10060H20K00			20					0.914	
MCM10060H30K00			30					1.104	
MCM10070H10K00	700	733 (751)	10	962	880	800	9	0.893	18.0
MCM10070H20K00			20					1.007	
MCM10070H30K00			30					1.197	
MCM10080H10K00	800	833 (851)	10	1 062	980	900	10	0.987	19.7
MCM10080H20K00			20					1.101	
MCM10080H30K00			30					1.291	
MCM10090H10K00	900	933 (951)	10	1 162	1 080	1 000	11	1.081	21.4
MCM10090H20K00			20					1.195	
◇MCM10100H10K00			10					1.174	
◇MCM10100H20K00	20	1.288							

Note: Dimension G is 90 for items marked with ◇.

Monocarrier dynamic torque specification (N · cm)

Ball screw lead (mm)	Notes:	
	10	2.7 – 10.8
	20	3.1 – 12.7
30	5.1 – 18.0	

Notes:
1. Frictional resistance of NSK K1 is included in dynamic torque in table.
2. Grease is packed into ball screw, linear guide parts and support unit.
3. Consult NSK for life estimates under large moment loads.

Basic load rating

Lead <i>l</i> (mm)	Shaft dia <i>d</i> (mm)	Basic dynamic load rating (N)				Basic static load rating (N)		Support unit load limit (N)
		Ball screw <i>C_a</i>	Linear guides <i>C</i>	Support unit <i>C_a</i>	Rated running distance <i>L_a</i> (km)	Ball screw <i>C_{0a}</i>	Linear guides <i>C₀</i>	
10	φ 20	11 000	33 500	7 600	10	21 100	29 400	3 380
20		7 060	26 600		20	12 700		
30		11 700	23 200		30	22 700		

Basic static moment load of linear guide

Slider	Basic static moment load (N · m)		
	Rolling <i>M_{RO}</i>	Pitching <i>M_{PO}</i>	Yawing <i>M_{YO}</i>
Single	1 170	425	425

1-5. 3 MCM Series Accessories

1-5. 3. 1 Sensor Unit

●Proximity switch

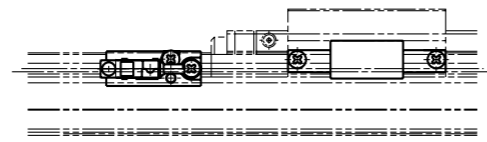
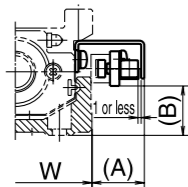

(Example of assembly)

Model No.	Reference No.			A (mm)	B (mm)	Body width W (mm)
MCM02	MC-SR02-00	MC-SR02-01	MC-SR02-02	17	2	28
MCM03	MC-SR03-10	MC-SR03-11	MC-SR03-12	17	3	34
MCM05	MC-SR05-10	MC-SR05-11	MC-SR05-12	17	15	48.6
MCM06	MC-SR06-10	MC-SR06-11	MC-SR06-12	17	19	58
MCM08	MC-SR08-10	MC-SR08-11	MC-SR08-12	16	27	80
MCM10	MC-SR10-10	MC-SR10-11	MC-SR10-12	16	35	100
Quantity	Proximity switch (normally open contact)	—	3	1	E2S-W13 (OMRON Corp.)	
	Proximity switch (normally close contact)	3	—	2	E2S-W14 (OMRON Corp.)	

- Notes: 1. See page 135 for proximity switch specification.
 2. A sensor unit consists of sensors, a sensor dog and sensor mounting parts.
 3. Sensor unit for MCM02 contains two sensor dogs.
 4. A spacer plate is required when using a cover unit or sensor unit for MCM03 with the lead of 1 or 2 mm. (Refer to page 51.)

●Photo sensor

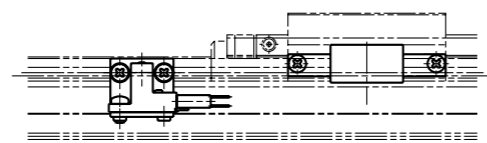
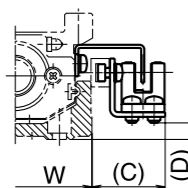

(Example of assembly)

Model No.	Reference No.	C (mm)	D (mm)	Body width W (mm)	Remarks
MCM03	MC-SR03-13	24	0.5	34	EE-SX674 (OMRON Corp.) 3 sets (EE-1001 connector attachment)
MCM05	MC-SR05-13	24	5	48.6	
MCM06	MC-SR06-13	24	9	58	
MCM08	MC-SR08-13	23	17	80	
MCM10	MC-SR10-13	22	24	100	

- Notes: 1. See page 136 for photo sensor specification.
 2. A sensor unit consists of sensors, a sensor dog and sensor mounting parts.
 3. A spacer plate is required when using a cover unit or sensor unit for MCM03 with the lead of 1 or 2 mm. (Refer to page 51.)

(1) Sensor Rail

Sensor rail for MCM03: MC-SRL3- * * * *

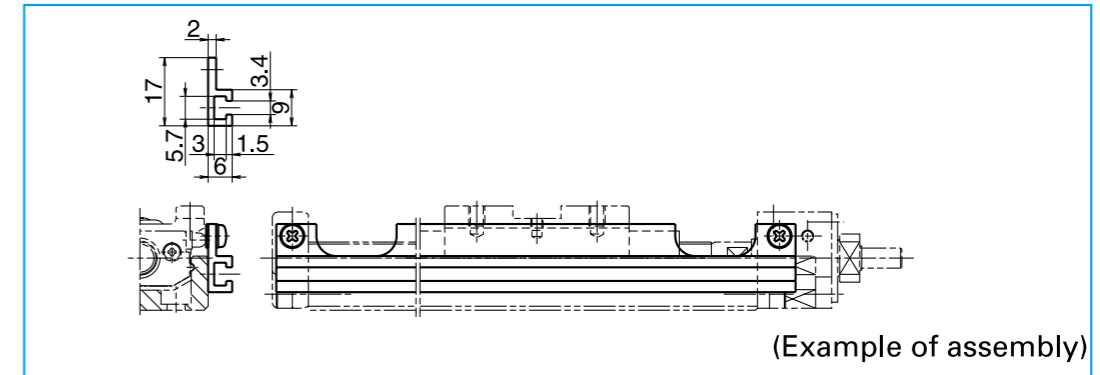

Sensor rail for MCM05: MC-SRL5- * * * *

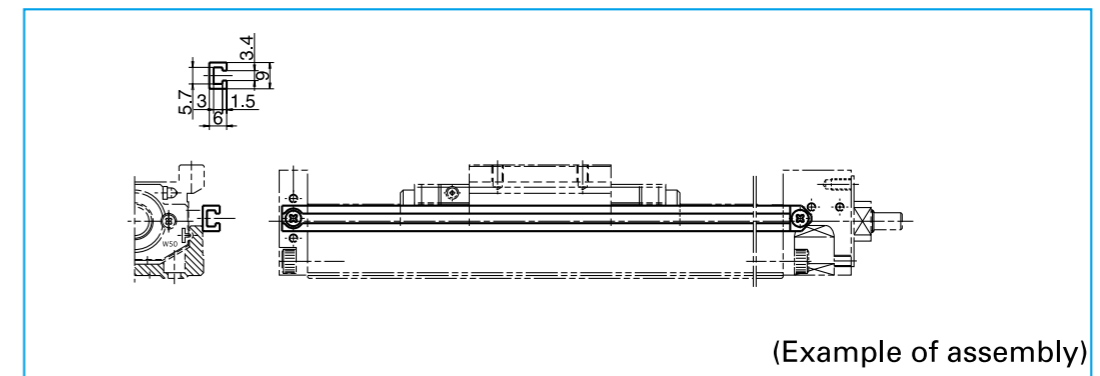

Sensor rail for MCM02: MC-SRL2- * * * *

Sensor rail for MCM06: MC-SRL6- * * * *

Sensor rail for MCM08: MC-SRL8- * * * *

Sensor rail for MCM10: MC-SRL1- * * * *

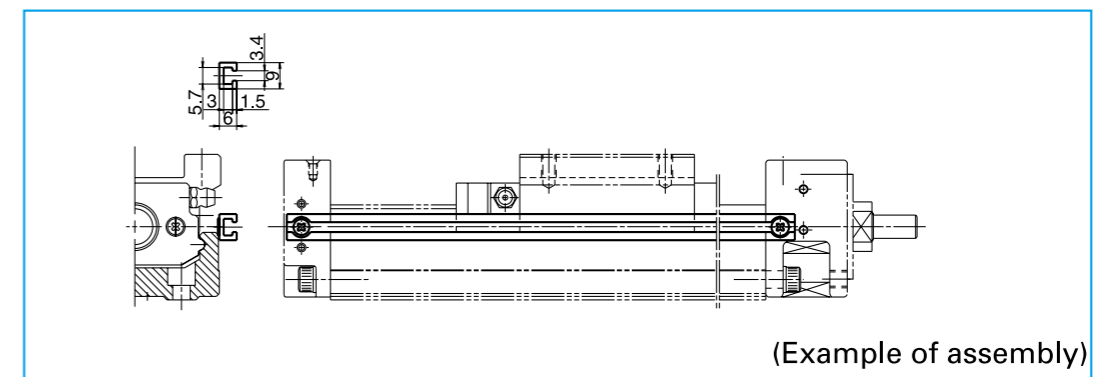

- Notes: 1. * * * * is the same as rail dimension L₂.
 2. Please assemble the attached seat between the sensor rail and the support unit for MCM03, MCM05, MCM06 and MCM08.
 3. For combinations of sensors and rails, see pages 49 to 50.

MCM Series and Sensor Rail Combination Table

Table 4

Model No.	Body length L ₂ (mm)	Reference No.	Sensor rail reference No.
MCM02	100	MCM02005H01K MCM02005P01K MCM02005H02K MCM02005P02K	MC-SRL2-0100 [*]
		MCM02010H01K MCM02010P01K MCM02010H02K MCM02010P02K	MC-SRL2-0150
		MCM02015H01K MCM02015P01K MCM02015H02K MCM02015P02K	MC-SRL2-0200
MCM03	115	MCM03005P01K00 MCM03005P02K00	MC-SRL3-0115
	140	MCM03005H05K00 MCM03005H10K00 MCM03005H12K00 MCM03005H15K00	MC-SRL3-0140
	190	MCM03010P01K00 MCM03010P02K00 MCM03010H05K00 MCM03010H10K00 MCM03010H12K00 MCM03010H15K00	MC-SRL3-0190
	240	MCM03015P01K00 MCM03015P02K00 MCM03015H05K00 MCM03015H10K00 MCM03015H12K00 MCM03015H15K00	MC-SRL3-0240
	290	MCM03020H05K00 MCM03020H10K00 MCM03020H12K00 MCM03020H15K00	MC-SRL3-0290
	340	MCM03025H05K00 MCM03025H10K00 MCM03025H12K00 MCM03025H15K00	MC-SRL3-0340
MCM05	180	MCM05005H05K00 MCM05005H10K00 MCM05005H20K00	MC-SRL5-0180
	230	MCM05010H05K00 MCM05010H10K00 MCM05010H20K00	MC-SRL5-0230
	280	MCM05015H05K00 MCM05015H10K00 MCM05015H20K00 MCM05006H10D00	MC-SRL5-0280
	330	MCM05020H05K00 MCM05020H10K00 MCM05020H20K00 MCM05011H10D00	MC-SRL5-0330
	380	MCM05025H05K00 MCM05025H10K00 MCM05025H20K00 MCM05016H10D00	MC-SRL5-0380
	430	MCM05030H05K00 MCM05030H10K00 MCM05030H20K00 MCM05030H30K00 MCM05021H10D00 MCM05021H20D00	MC-SRL5-0430
530	MCM05040H05K00 MCM05040H10K00 MCM05040H20K00 MCM05040H30K00 MCM05031H10D00	MC-SRL5-0530	

Model No.	Body length L ₂ (mm)	Reference No.	Sensor rail reference No.
MCM05	530	MCM05031H20D00	MC-SRL5-0530
	630	MCM05050H05K00 MCM05050H10K00 MCM05050H20K00 MCM05050H30K00 MCM05041H10D00 MCM05041H20D00	MC-SRL5-0630
	730	MCM05060H05K00 MCM05060H10K00 MCM05060H20K00 MCM05060H30K00 MCM05051H10D00 MCM05051H20D00	MC-SRL5-0730
MCM06	190	MCM06005H05K02 MCM06005H10K00 MCM06005H20K00	MC-SRL6-0190
	240	MCM06010H05K02 MCM06010H10K00 MCM06010H20K00	MC-SRL6-0240
	290	MCM06015H05K02 MCM06015H10K00 MCM06015H20K00	MC-SRL6-0290
	340	MCM06020H05K02 MCM06020H10K00 MCM06020H20K00 MCM06011H05D02 MCM06011H10D00	MC-SRL6-0340
	390	MCM06025H05K02 MCM06025H10K00 MCM06025H20K00	MC-SRL6-0390
	440	MCM06030H05K02 MCM06030H10K00 MCM06030H20K00 MCM06021H05D02 MCM06021H10D00 MCM06021H20D00	MC-SRL6-0440
	540	MCM06040H05K02 MCM06040H10K00 MCM06040H20K00 MCM06031H05D02 MCM06031H10D00 MCM06031H20D00	MC-SRL6-0540
	640	MCM06050H05K02 MCM06050H10K00 MCM06050H20K00 MCM06041H05D02 MCM06041H10D00 MCM06041H20D00	MC-SRL6-0640
	740	MCM06060H05K02 MCM06060H10K00 MCM06060H20K00 MCM06051H10D00 MCM06051H20D00	MC-SRL6-0740
	840	MCM06070H05K02 MCM06070H10K00 MCM06070H20K00 MCM06061H10D00 MCM06061H20D00	MC-SRL6-0840
940	MCM06080H05K02 MCM06080H10K00 MCM06080H20K00 MCM06071H10D00 MCM06071H20D00	MC-SRL6-0940	

*) When using NSK standard sensors, prepare two sensor rails. Two sensor rails will also be required for another Monocarriers depending on signal points of sensors. Contact NSK for details.

Model No.	Body length L ₂ (mm)	Reference No.	Sensor rail reference No.
MCM08	220	MCM08005H05K02 MCM08005H10K00	MC-SRL8-0220
	270	MCM08010H05K02 MCM08010H10K00 MCM08010H20K00	MC-SRL8-0270
	320	MCM08015H05K02 MCM08015H10K00 MCM08015H20K00	MC-SRL8-0320
	370	MCM08020H05K02 MCM08020H10K00 MCM08020H20K00 MCM08008H10D00	MC-SRL8-0370
	420	MCM08025H05K02 MCM08025H10K00 MCM08025H20K00	MC-SRL8-0420
	470	MCM08030H05K02 MCM08030H10K00 MCM08030H20K00 MCM08018H10D00 MCM08018H20D00	MC-SRL8-0470
	570	MCM08040H05K02 MCM08040H10K00 MCM08040H20K00 MCM08040H30K00 MCM08028H10D00 MCM08028H20D00	MC-SRL8-0570
	670	MCM08050H05K02 MCM08050H10K00 MCM08050H20K00 MCM08050H30K00 MCM08038H10D00 MCM08038H20D00	MC-SRL8-0670
	770	MCM08060H05K02 MCM08060H10K00 MCM08060H20K00 MCM08060H30K00 MCM08048H10D00 MCM08048H20D00	MC-SRL8-0770
	870	MCM08070H05K02 MCM08070H10K00 MCM08070H20K00 MCM08070H30K00 MCM08058H10D00 MCM08058H20D00	MC-SRL8-0870
970	MCM08080H05K02 MCM08080H10K00 MCM08080H20K00 MCM08080H30K00 MCM08068H10D00 MCM08068H20D00	MC-SRL8-0970	

Model No.	Body length L ₂ (mm)	Reference No.	Sensor rail reference No.
MCM10	280	MCM10010H10K00 MCM10010H20K00	MC-SRL1-0280
	330	MCM10015H10K00 MCM10015H20K00	MC-SRL1-0330
	380	MCM10020H10K00 MCM10020H20K00 MCM10007H10K00	MC-SRL1-0380
	430	MCM10025H10K00 MCM10025H20K00	MC-SRL1-0430
	480	MCM10030H10K00 MCM10030H20K00 MCM10017H10K00 MCM10017H20K00	MC-SRL1-0480
	580	MCM10040H10K00 MCM10040H20K00 MCM10027H10K00 MCM10027H20K00	MC-SRL1-0580
	680	MCM10050H10K00 MCM10050H20K00 MCM10050H30K00 MCM10037H10K00 MCM10037H20K00	MC-SRL1-0680
	780	MCM10060H10K00 MCM10060H20K00 MCM10060H30K00 MCM10047H10K00 MCM10047H20K00	MC-SRL1-0780
	880	MCM10070H10K00 MCM10070H20K00 MCM10070H30K00 MCM10057H10K00 MCM10057H20K00	MC-SRL1-0880
	980	MCM10080H10K00 MCM10080H20K00 MCM10080H30K00 MCM10067H10K00 MCM10067H20K00	MC-SRL1-0980
	1 080	MCM10090H10K00 MCM10090H20K00	MC-SRL1-1080
	1 180	MCM10100H10K00 MCM10100H20K00 MCM10087H10K00 MCM10087H20K00	MC-SRL1-1180

1-5. 3. 2 Cover Unit

Cover Unit for MCM02

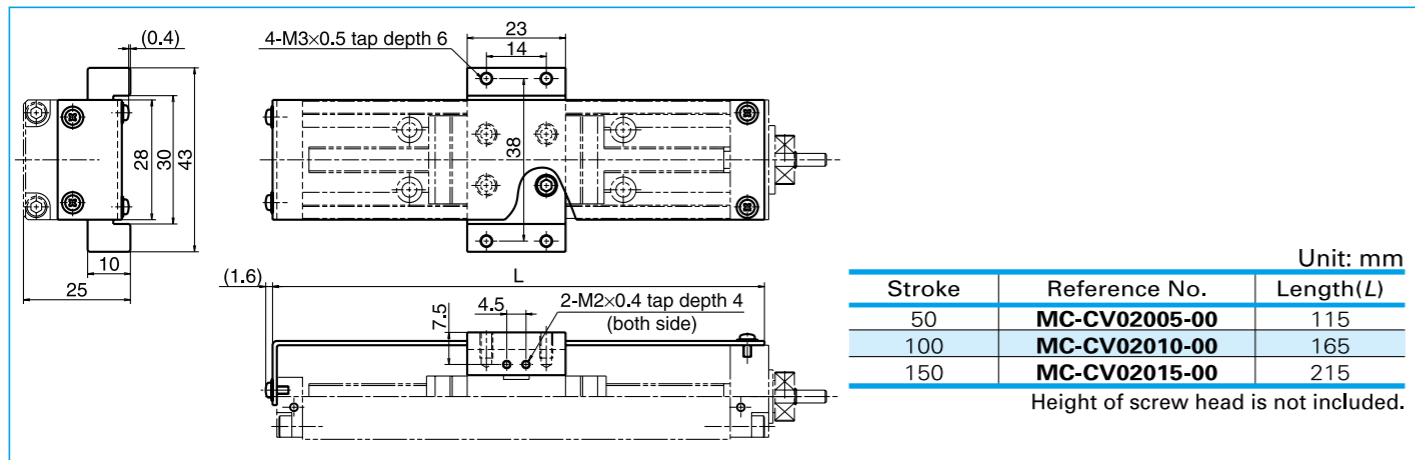

Cover Unit for MCM03

Notes: 1. When the cover is used for leads 1 and 2, an optional spacer plate (nominal No.: MC-SP03-00) is required.
2. When the cover is used for lead 15, an optional spacer plate (nominal No.: MC-SP03-01) is required. A full cover unit cannot be installed for lead 15.

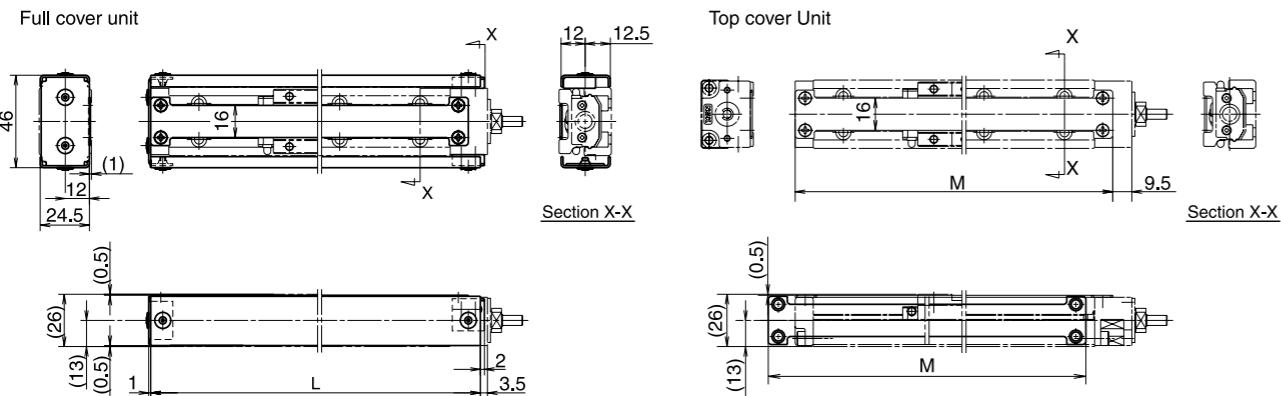

Stroke	Reference No.		Cover length	
	Top cover unit	Full cover unit	Length (L)	Length (M)
50 (lead 1, 2)	MC-CV03005-02	*MC-CV03005-01	139	133
50 (lead 5, 10, 12, 15)	MC-CV03005-02A	*MC-CV03005-01A	164	158
100	MC-CV03010-02	*MC-CV03010-01	214	208
150	MC-CV03015-02	*MC-CV03015-01	264	258
200	MC-CV03020-02	*MC-CV03020-01	314	308
250	MC-CV03025-02	*MC-CV03025-01	364	358

*) The full-cover unit cannot be used when the sensor unit is used. Height of screw head is not included.

Spacer for MCM03 (Optional)

MC-SP03-00 (for ball screw lead 1 and 2 mm)

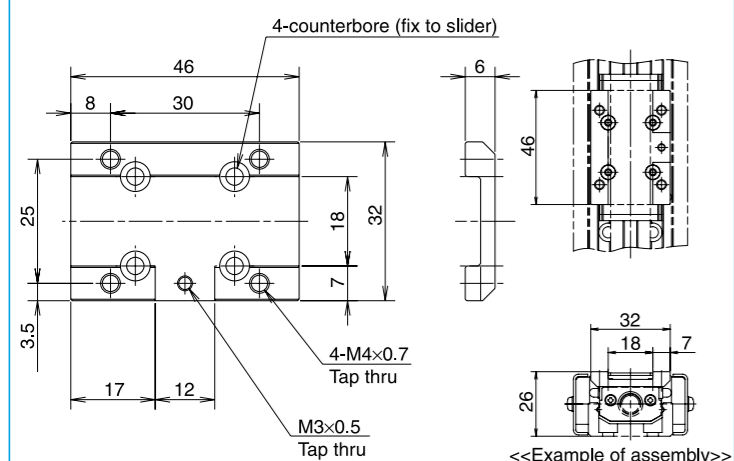

Note: Spacer is required when using sensor unit and cover unit.

MC-SP03-01 (for ball screw lead 15 mm)

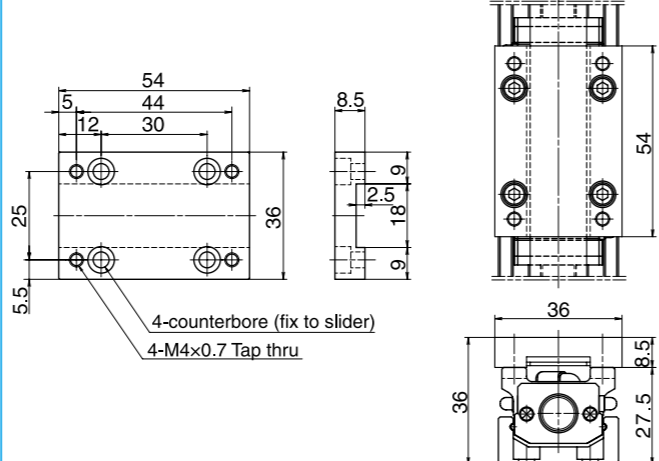

Note: To use an upper surface cover, use it during assembly.

Cover unit for MCM05, 06, 08, and 10

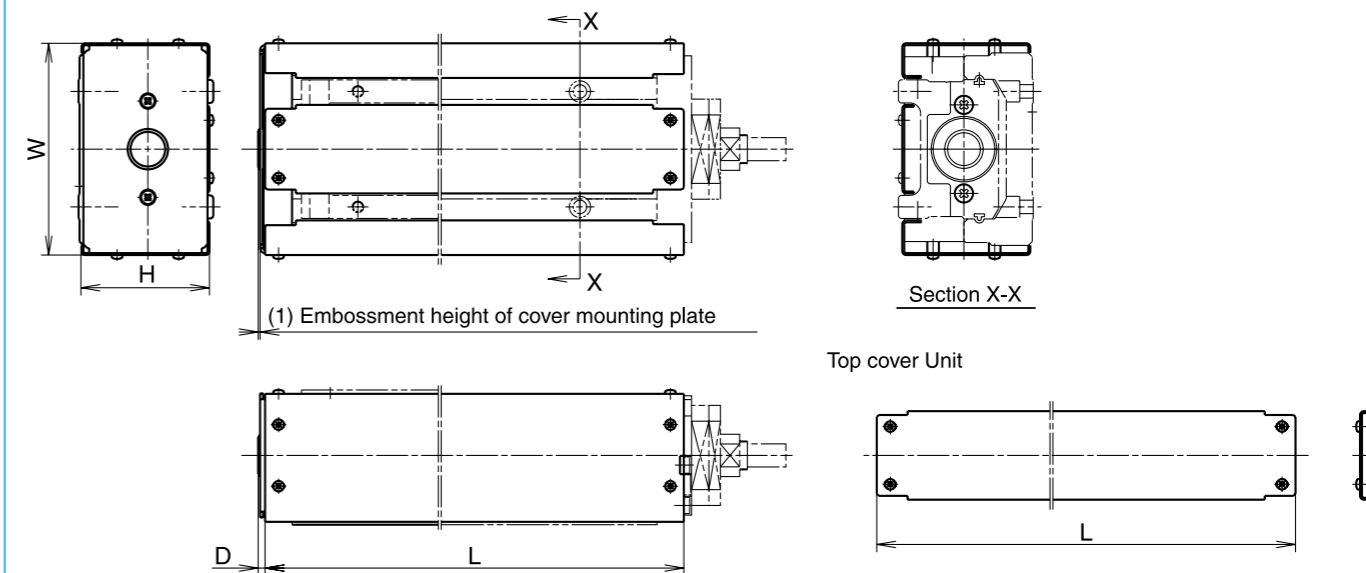

Unit: mm

Model No.	Stroke		Cover unit reference No.		Cover length			
	Single slider	Double slider	Top cover Unit	Full cover Unit*1	Length (L)	Height (H)	Width (W)	End part (D)
MCM05	50	—	MC-CV05005-01	MC-CV05005-00	200	38.5	65	2.6
	100	—	MC-CV05010-01	MC-CV05010-00	250			
	150	60	MC-CV05015-01	MC-CV05015-00	300			
	200	110	MC-CV05020-01	MC-CV05020-00	350			
	250	160	MC-CV05025-01	MC-CV05025-00	400			
	300	210	MC-CV05030-01	MC-CV05030-00	450			
	400	310	MC-CV05040-01	MC-CV05040-00	550			
	500	410	MC-CV05050-01	MC-CV05050-00	650			
MCM06	600	510	MC-CV05060-01	MC-CV05060-00	750	48.5	75	*2
	50	—	MC-CV06005-01	MC-CV06005-00	225			
	100	—	MC-CV06010-01	MC-CV06010-00	275			
	150	—	MC-CV06015-01	MC-CV06015-00	325			
	200	110	MC-CV06020-01	MC-CV06020-00	375			
	250	—	MC-CV06025-01	MC-CV06025-00	425			
	300	210	MC-CV06030-01	MC-CV06030-00	475			
	400	310	MC-CV06040-01	MC-CV06040-00	575			
	500	410	MC-CV06050-01	MC-CV06050-00	675			
	600	510	MC-CV06060-01	MC-CV06060-00	775			
	700	610	MC-CV06070-01	MC-CV06070-00	875			
	800	710	MC-CV06080-01	MC-CV06080-00	975			
MCM08	50	—	MC-CV08005-01	MC-CV08005-00	248	56.5	90	2.6
	100	—	MC-CV08010-01	MC-CV08010-00	298			
	150	—	MC-CV08015-01	MC-CV08015-00	348			
	200	80	MC-CV08020-01	MC-CV08020-00	398			
	250	—	MC-CV08025-01	MC-CV08025-00	448			
	300	180	MC-CV08030-01	MC-CV08030-00	498			
	400	280	MC-CV08040-01	MC-CV08040-00	598			
	500	380	MC-CV08050-01	MC-CV08050-00	698			
	600	480	MC-CV08060-01	MC-CV08060-00	798			
	700	580	MC-CV08070-01	MC-CV08070-00	898			
	800	680	MC-CV08080-01	MC-CV08080-00	998			
	MCM10	100	—	MC-CV10010-01	MC-CV10010-00			
150		—	MC-CV10015-01	MC-CV10015-00	358			
200		70	MC-CV10020-01	MC-CV10020-00	408			
250		—	MC-CV10025-01	MC-CV10025-00	458			
300		170	MC-CV10030-01	MC-CV10030-00	508			
400		270	MC-CV10040-01	MC-CV10040-00	608			
500		370	MC-CV10050-01	MC-CV10050-00	708			
600		470	MC-CV10060-01	MC-CV10060-00	808			
700		570	MC-CV10070-01	MC-CV10070-00	908			
800		670	MC-CV10080-01	MC-CV10080-00	1008			
900		—	MC-CV10090-01	MC-CV10090-00	1108			
1000		870	MC-CV10100-01	MC-CV10100-00	1208			

Note: The dimensions of cover shown above do not include the head height of fixing machine screws. Add the head of machine screws of approximately 2.5 mm to the outer measurement of a cover unit. Set a margin for mechanical interference with surrounding components.

*1) When using sensor unit, full-cover unit cannot be used.

*2) A cover mounting plate is not used to MCM06.

1-5. 3 Motor Bracket

Motor models are subject to change at the motor manufacturers. For details, please contact the manufacturer.

Motor bracket for MCM02

Reference number
MC-BK02-128-00

1) Motor bracket (A/L)
(Black anodized aluminum)

2) Hexagon socket head cap screw
(M3×0.5, length 10)

2-M3×0.5 tap depth 6

4-φ 3.5 drill thru
PCD 28, 90° equally spaced

Diameter for coupling
φ 17 or less

Note: Be sure to align centerlines when installing motor.

Compatible motor	
Maker	Motor models
YASKAWA Electric Corp. (Σ- mini Series)	SGMM-A1 (10W) SGMM-A2 (20W)

Reference number
MC-BK02-133-00

1) Motor bracket (A/L)
(Black anodized aluminum)

2) Hexagon socket head cap screw
(M3×0.5, length 10)

2-M3×0.5 tap depth 6

4-φ 2.6 drill thru
PCD 33, 90° equally spaced

Diameter for coupling
φ 17 or less

Note: Be sure to align centerlines when installing motor.

Compatible motor	
Maker	Motor models
Mitsubishi Electric Corp. (Melservo series)	HC-AQ013 (10W) HC-AQ023 (20W)

Reference number
MC-BK02-223-00

1) Motor bracket (A/L)
(Black anodized aluminum)

2) Hexagon socket head cap screw
(M3×0.5, length 10)

2-M3×0.5 tap depth 6

4-φ 3 drill thru

Diameter for coupling
φ 17 or less

Note: Be sure to align centerlines when installing motor.

Compatible motor	
Maker	Motor models
ORIENTAL MOTOR Co., Ltd.	PMU33/35 (5-phase stepping motor) PMC33/35 (5-phase stepping motor)

Motor bracket for MCM03

Reference number
MC-BK03-146-00

1) Motor bracket (A/L)
(Black anodized aluminum)

2) Hexagon socket head cap screw (M4, length 12)

3) Hexagon socket head cap screw (M3, length 10)

4-φ 3.5 drill thru

4-M4×0.7 tap thru
PCD 46, 90° equally spaced

Diameter for coupling
(26)

Monocarrier

Motor

(Example of assembly)

Notes: 1. Be sure to align centerlines when installing motor.
2. Be careful in the assembly orientation of bracket.
3. Because bracket is made by sand casting, external dimensions are for reference only.

Compatible motor	
Maker	Motor models
YASKAWA Electric Corp.	SGMAH-A3(30W), SGMJV-A5A(50W), SGMJV-A5A(50W) SGMJV-01A(100W), SGMJV-01A(100W), SGMJV-01A(100W), SGMJV-C2A(150W)
Mitsubishi Electric Corp.	HF-KP053(50W), HF-MP053(50W), HC-KFS053(50W), HC-MFS053(50W) HF-KP13(100W), HF-MP13(100W), HC-KFS13(100W), HC-MFS13(100W)
OMRON Corp.	R88M-W03(30W), R88M-W05(50W), R88M-W10(100W)
SANYO DENKI Co., Ltd.	P30B04003(30W), P30B04005(50W), P30B04010(100W)

Motor bracket for MCM03

Reference number
MC-BK03-148-01

1) Motor bracket (A/L)
(Black anodized aluminum)

2) Hexagon socket head cap screw (M3, length 10)

4-φ 3.5 drill thru

4-M3×0.5 tap thru
PCD 48, 90° equally spaced

Diameter for coupling
(26)

Monocarrier

Motor

(Example of assembly)

Notes: 1. Be sure to align centerlines when installing motor.
2. Be careful in the assembly orientation of bracket.
3. Because bracket is made by sand casting, external dimensions are for reference only.

Compatible motor	
Maker	Motor models
SANYO DENKI Co., Ltd.	P50B04006 (60W), P50B04010 (100W)

Motor bracket for MCM03

Reference number
MC-BK03-231-00

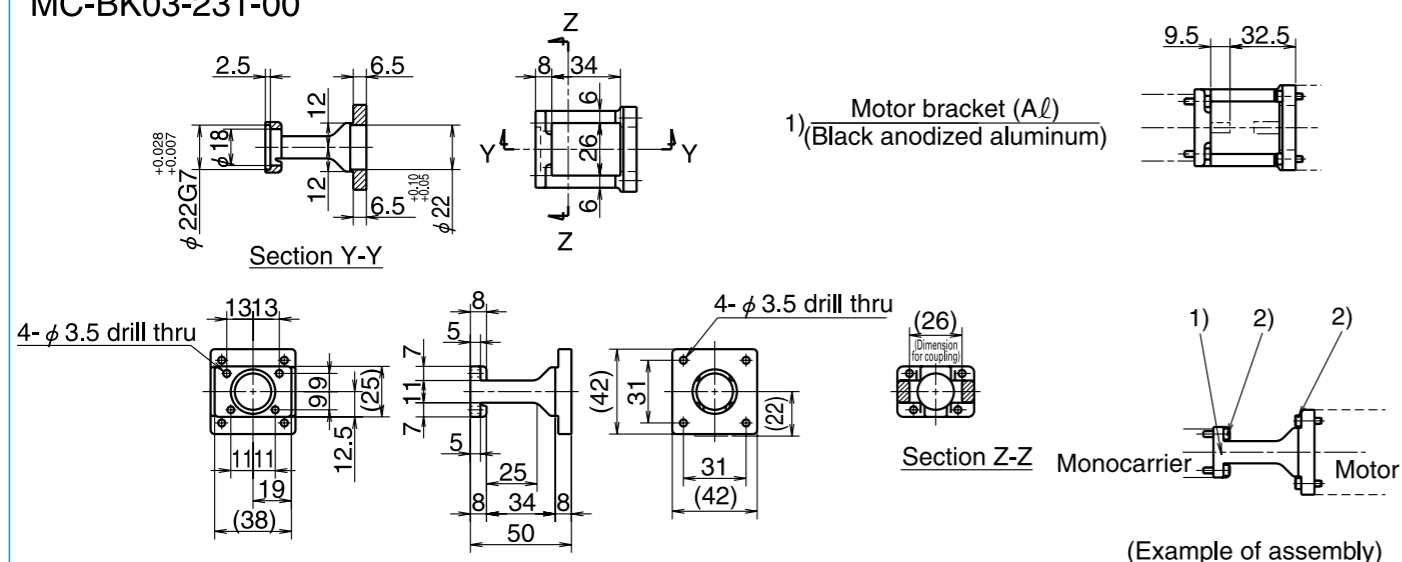

Notes: 1. Be sure to align centerlines when installing motor.
2. Be careful in the assembly orientation of bracket.
3. Because bracket is made by sand casting, external dimensions are for reference only.

2) Hexagon socket head cap screw (M3, length 10)

Compatible motor	
Maker	Motor models
SANYO DENKI Co., Ltd.	PBM423xxx, 103F55xx
ORIENTAL MOTOR Co., Ltd.	AS46, ASC46, UPK54x, PK54x, CSK54x, CFK54x UMK24x, CSK24x, PK24x

Motor bracket for MCM05

Reference number
MC-BK05-146-00

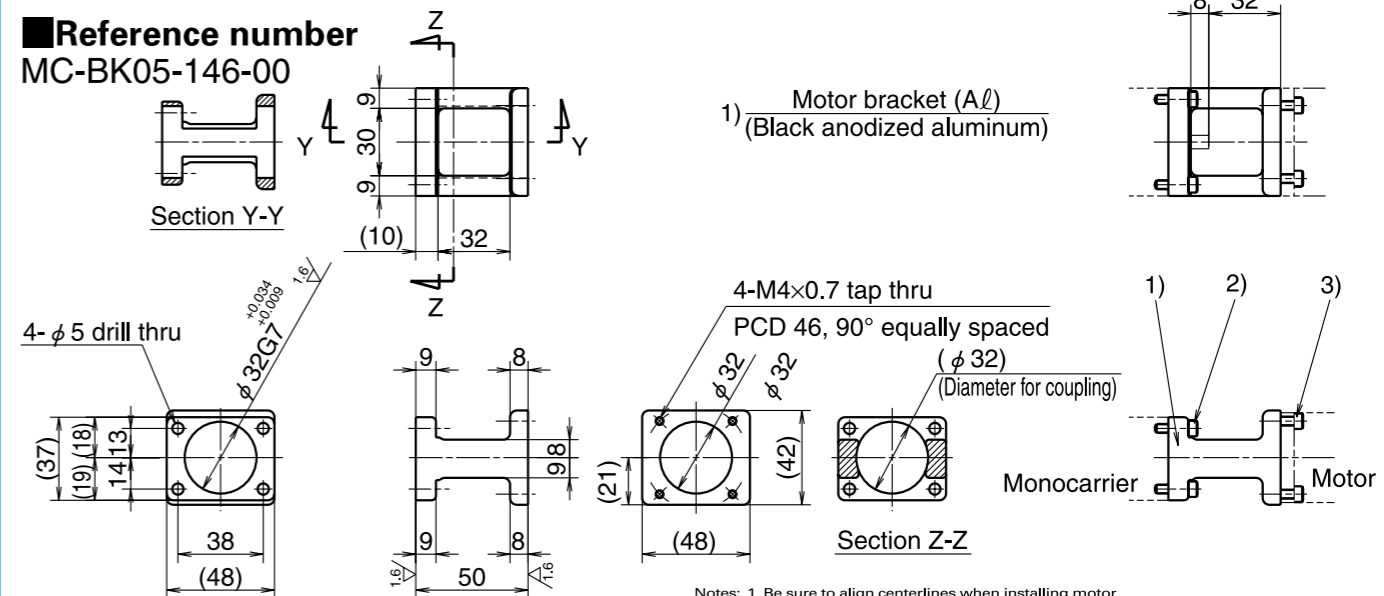

Notes: 1. Be sure to align centerlines when installing motor.
2. Be careful in the assembly orientation of bracket.
3. Because bracket is made by sand casting, external dimensions are for reference only.

2) Hexagon socket head cap screw (M4, length 15)

3) Hexagon socket head cap screw (M4, length 12)

Compatible motor	
Maker	Motor models
YASKAWA Electric Corp.	SGMAH-A3(30W), SGMJV-A5A(50W), SGMJV-A5A(50W) SGMJV-01A(100W), SGMJV-01A(100W), SGMJV-C2A(150W)
Mitsubishi Electric Corp.	HF-KP053(50W), HF-MP053(50W), HC-KFS053(50W), HC-MFS053(50W) HF-KP13(100W), HF-MP13(100W), HC-KFS13(100W), HC-MFS13(100W)
OMRON Corp.	R88M-W03(30W), R88M-W05(50W), R88M-W10(100W)
SANYO DENKI Co., Ltd.	P30B04003(30W), P30B04005(50W), P30B04010(100W)

Motor bracket for MCM05

Reference number
MC-BK05-145-00

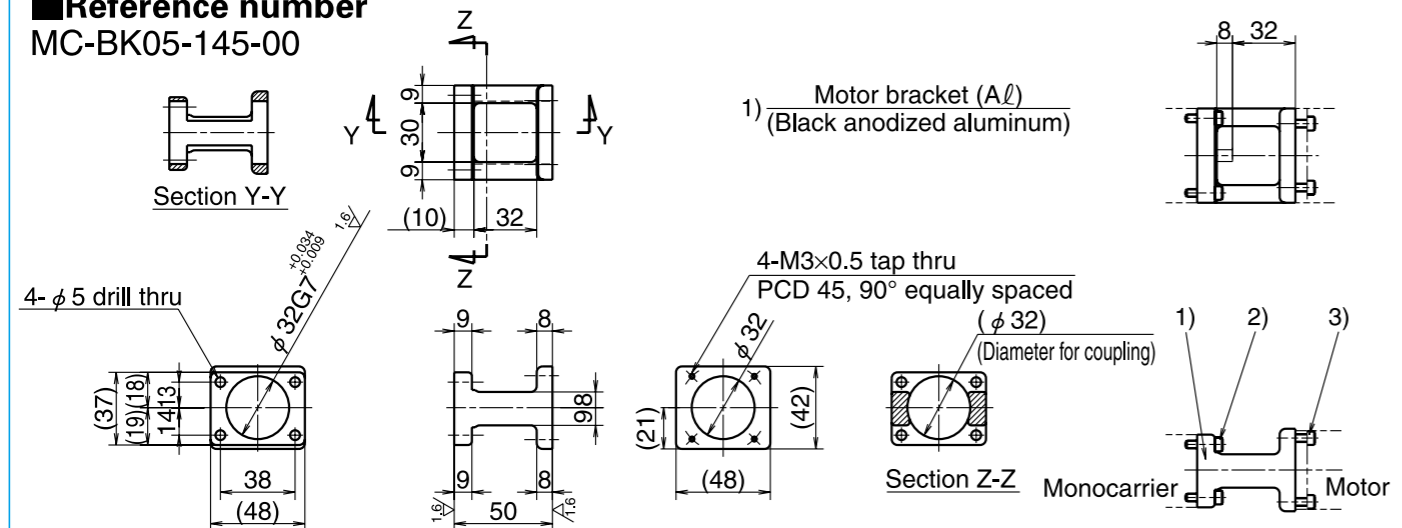

Notes: 1. Be sure to align centerlines when installing motor.
2. Be careful in the assembly orientation of bracket.
3. Because bracket is made by sand casting, external dimensions are for reference only.

2) Hexagon socket head cap screw (M4, length 15)

3) Hexagon socket head cap screw (M3, length 12)

Compatible motor	
Maker	Motor models
Panasonic Co., Ltd.	MSMD5A(50W), MSMD01(100W)

Motor bracket for MCM05

Reference number
MC-BK05-148-00

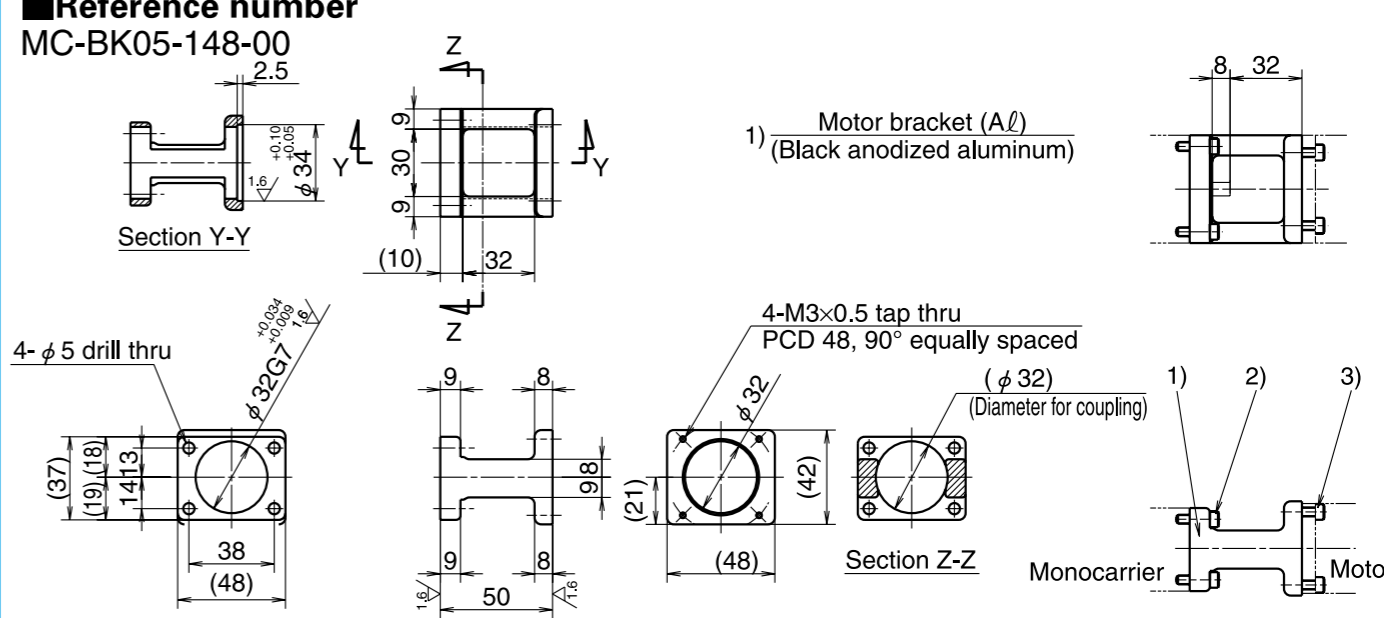

Notes: 1. Be sure to align centerlines when installing motor.
2. Be careful in the assembly orientation of bracket.
3. Because bracket is made by sand casting, external dimensions are for reference only.

2) Hexagon socket head cap screw (M4, length 15)

3) Hexagon socket head cap screw (M3, length 12)

Compatible motor	
Maker	Motor models
Panasonic Co., Ltd.	MAMA01(100W)

Motor bracket for MCM05

Reference number
MC-BK05-160-00

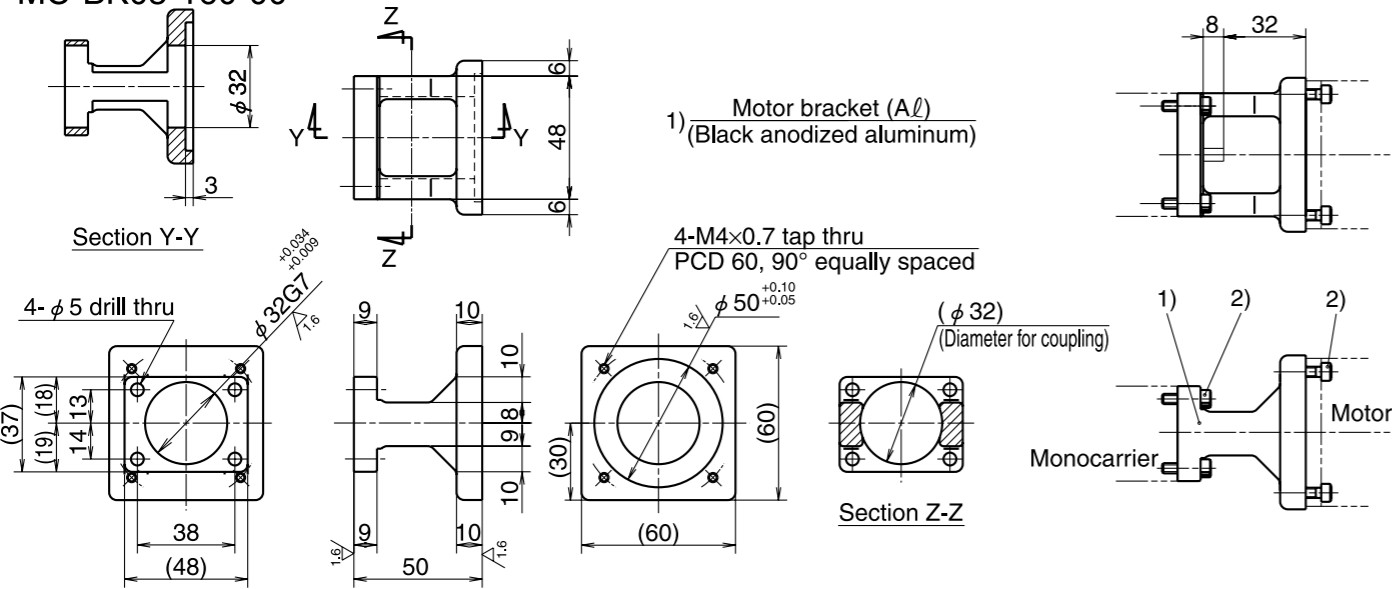

- 2) Hexagon socket head cap screw (M4, length 15)

Notes: 1. Be sure to align centerlines when installing motor.
2. Be careful in the assembly orientation of bracket.
3. Because bracket is made by sand casting, external dimensions are for reference only.

Compatible motor	
Maker	Motor models
SANYO DENKI Co., Ltd.	P50B05005(50W), P50B05010(100W), P50B05020(200W)

Motor bracket for MCM06

Reference number
MC-BK06-145-00

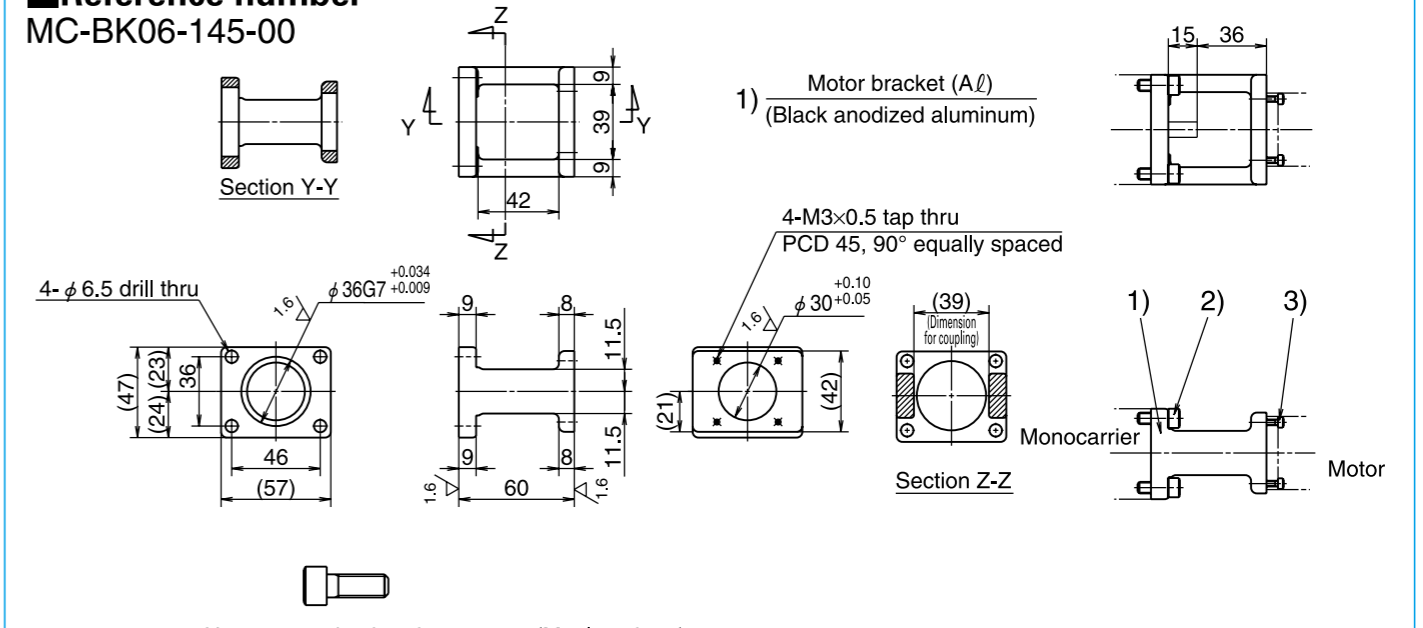

- 2) Hexagon socket head cap screw (M6, length 16)
3) Hexagon socket head cap screw (M3, length 12)

Notes: 1. Be sure to align centerlines when installing motor.
2. Be careful in the assembly orientation of bracket.
3. Because bracket is made by sand casting, external dimensions are for reference only.

Compatible motor	
Maker	Motor models
Panasonic Co., Ltd.	MSMD5A(50W), MSMD01(100W)

Motor bracket for MCM05

Reference number
MC-BK05-250-00

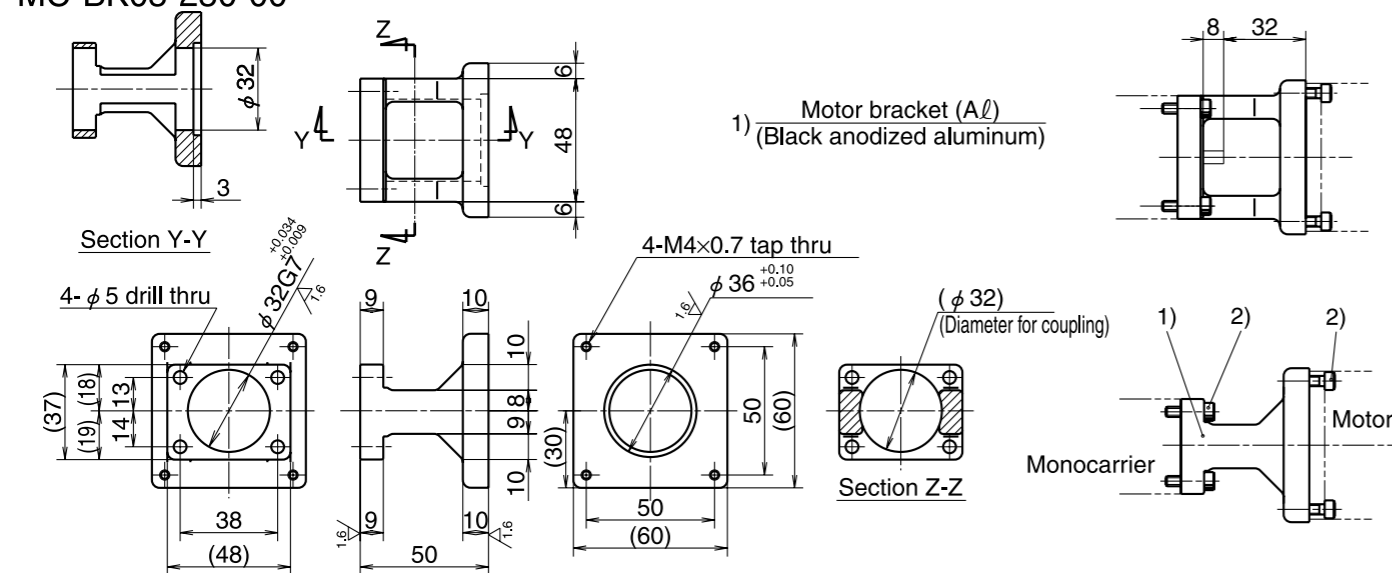

- 2) Hexagon socket head cap screw (M4, length 15)

Notes: 1. Be sure to align centerlines when installing motor.
2. Be careful in the assembly orientation of bracket.
3. Because bracket is made by sand casting, external dimensions are for reference only.

Compatible motor	
Maker	Motor models
SANYO DENKI Co., Ltd.	PBM603xxx, PBM604xxx, 103F78xx
ORIENTAL MOTOR Co., Ltd.	AS66, ASC66, UPK56x, UFK56x, PK56x, CSK56x, CFK56x

Motor bracket for MCM06

Reference number
MC-BK06-146-00

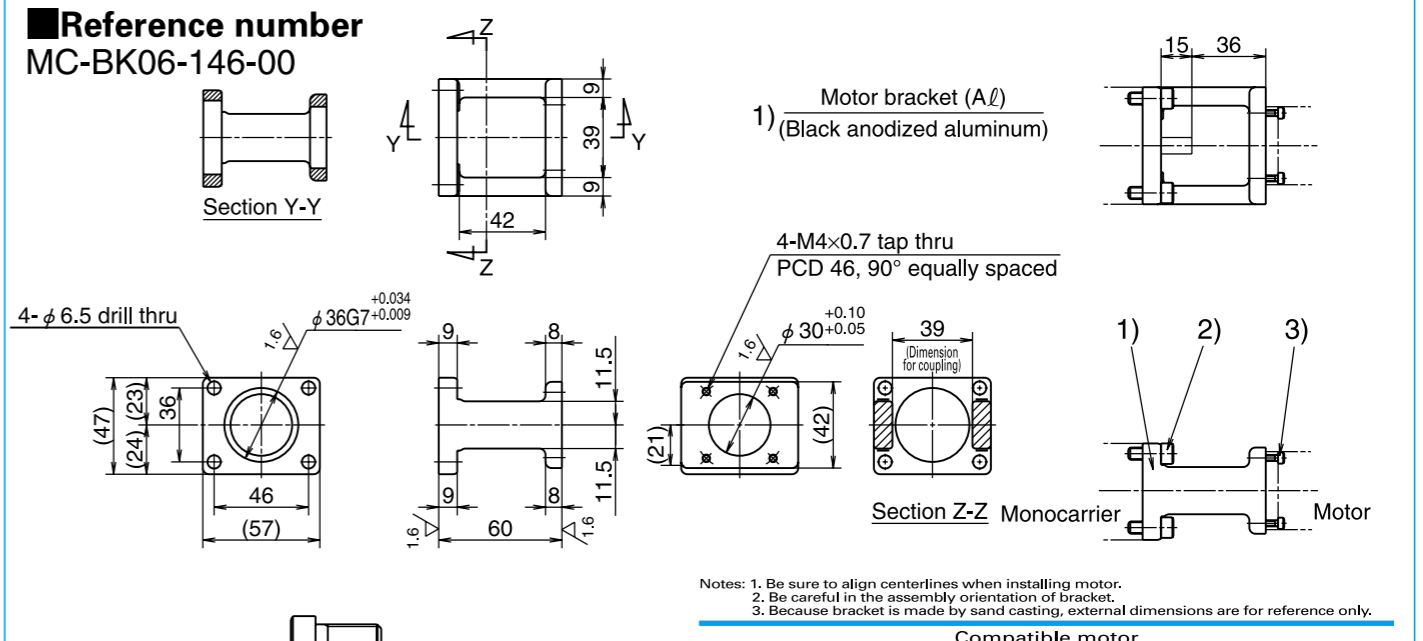

- 2) Hexagon socket head cap screw (M6, length 16)
3) Hexagon socket head cap screw (M4, length 12)

Notes: 1. Be sure to align centerlines when installing motor.
2. Be careful in the assembly orientation of bracket.
3. Because bracket is made by sand casting, external dimensions are for reference only.

Compatible motor	
Maker	Motor models
YASKAWA Electric Corp.	SGMJV-A5A(50W), SGMJV-A5A(50W), SGMJV-01A(100W), SGMJV-01A(100W), SGMJV-C2A(150W)
Mitsubishi Electric Corp.	HF-KP053(50W), HF-MP053(50W), HC-KFS053(50W), HC-MFS053(50W), HF-KP13(100W), HF-MP13(100W), HC-KFS13(100W), HC-MFS13(100W)
OMRON Corp.	R88M-W03(30W), R88M-W05(50W), R88M-W10(100W)
SANYO DENKI Co., Ltd.	P30B04003(30W), P30B04005(50W), P30B04010(100W)

Motor bracket for MCM06

Reference number
MC-BK06-250-00

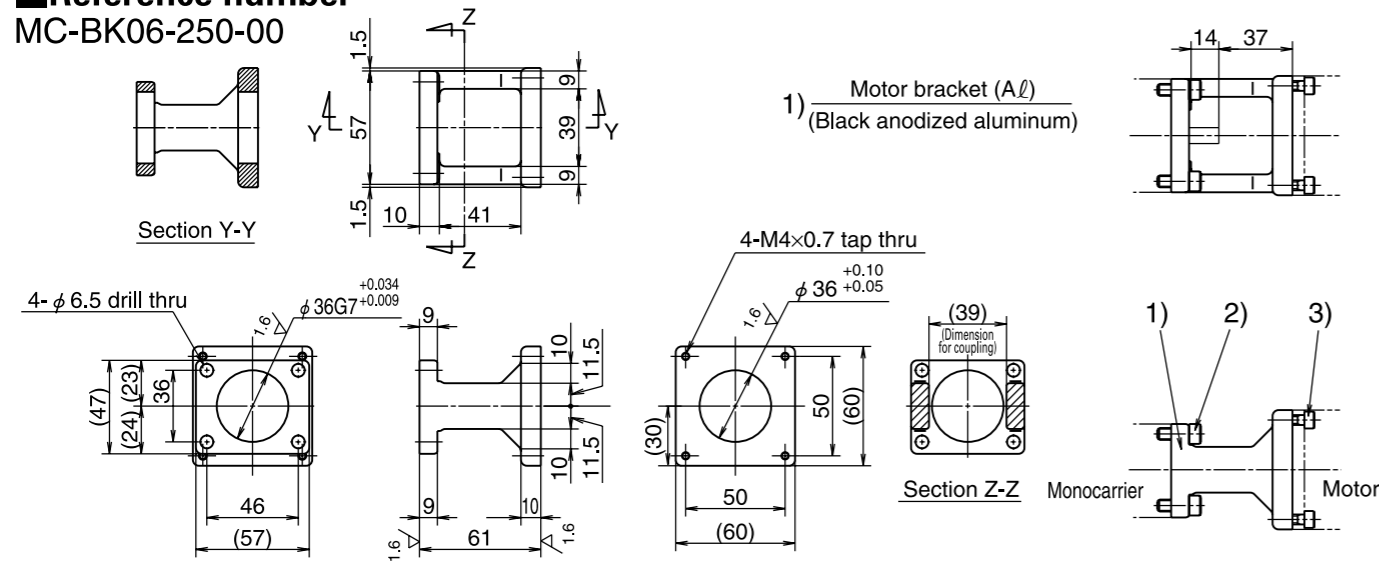

- 2) Hexagon socket head cap screw (M6, length 16)
- 3) Hexagon socket head cap screw (M4, length 14)

Notes: 1. Be sure to align centerlines when installing motor.
2. Be careful in the assembly orientation of bracket.
3. Because bracket is made by sand casting, external dimensions are for reference only.

Compatible motor	
Maker	Motor models
SANYO DENKI Co., Ltd.	PBM603xxx, PBM604xxx, 103F78xx
ORIENTAL MOTOR Co., Ltd.	AS66, ASC66, UPK56x, PK56x, CSK56x CFK56x, UFK56x

Motor bracket for MCM08

Reference number
MC-BK08-146-00

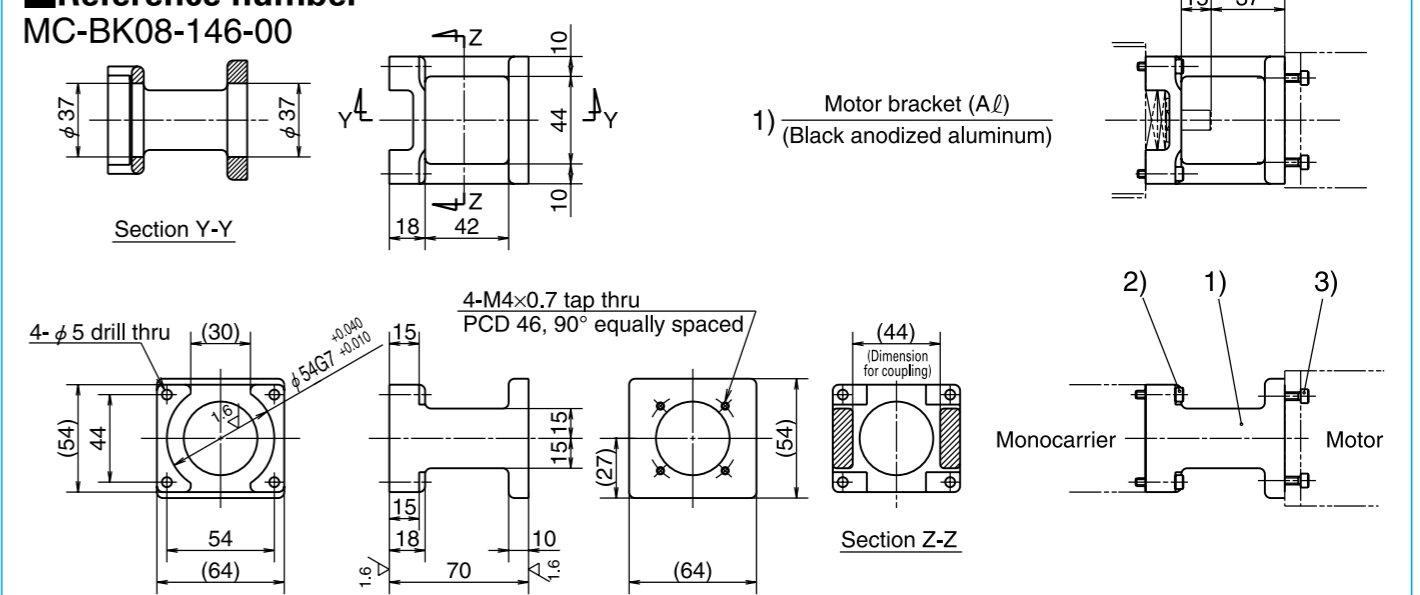

- 2) Hexagon socket head cap screw (M4, length 20)
- 3) Hexagon socket head cap screw (M4, length 14)

Notes: 1. Be sure to align centerlines when installing motor.
2. Be careful in the assembly orientation of bracket.
3. Because bracket is made by sand casting, external dimensions are for reference only.

Compatible motor	
Maker	Motor models
YASKAWA Electric Corp.	SGMJV-01A(100W), SGMJV-01A(100W), SGMJV-C2A(150W)
Mitsubishi Electric Corp.	HF-KP13(100W), HF-MP13(100W), HC-KFS13(100W), HC-MFS13(100W)
SANYO DENKI Co., Ltd.	P30B04003(30W), P30B04005(50W), P30B04010(100W)

Motor bracket for MCM08

Reference number
MC-BK08-145-00

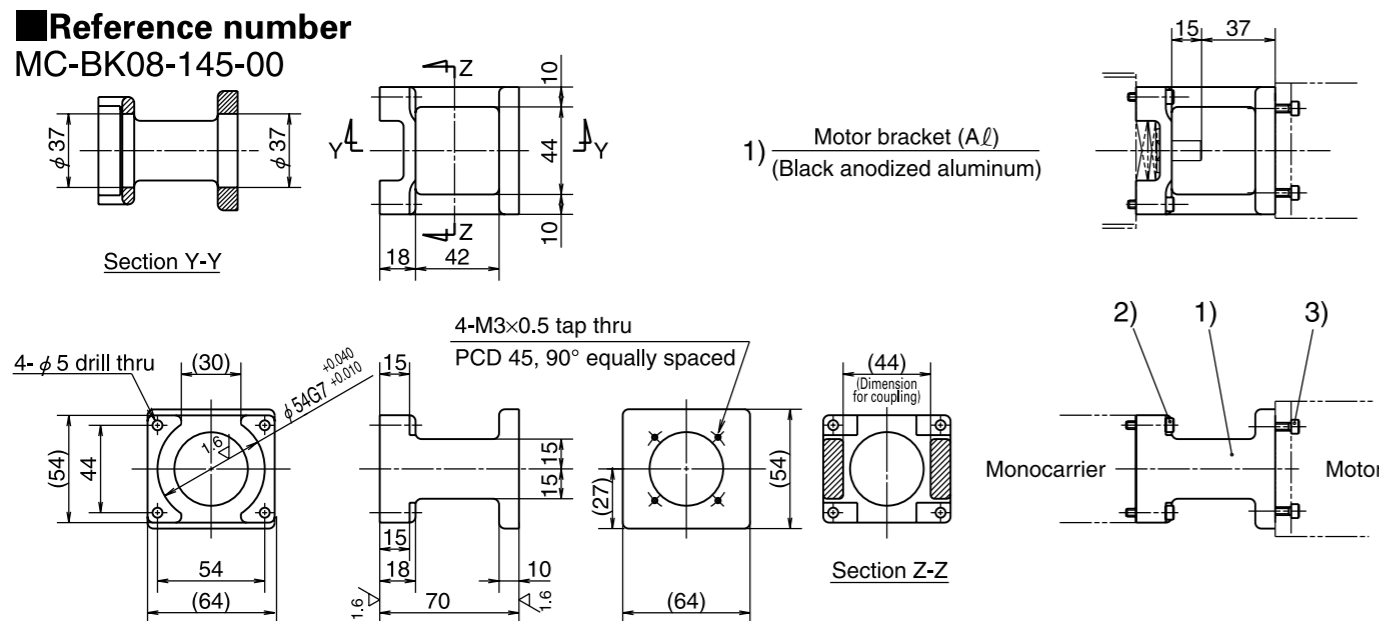

- 2) Hexagon socket head cap screw (M4, length 20)
- 3) Hexagon socket head cap screw (M3, length 12)

Notes: 1. Be sure to align centerlines when installing motor.
2. Be careful in the assembly orientation of bracket.
3. Because bracket is made by sand casting, external dimensions are for reference only.

Compatible motor	
Maker	Motor models
Panasonic Co., Ltd.	MSMD01(100W)

Motor bracket for MCM08

Reference number
MC-BK08-160-00

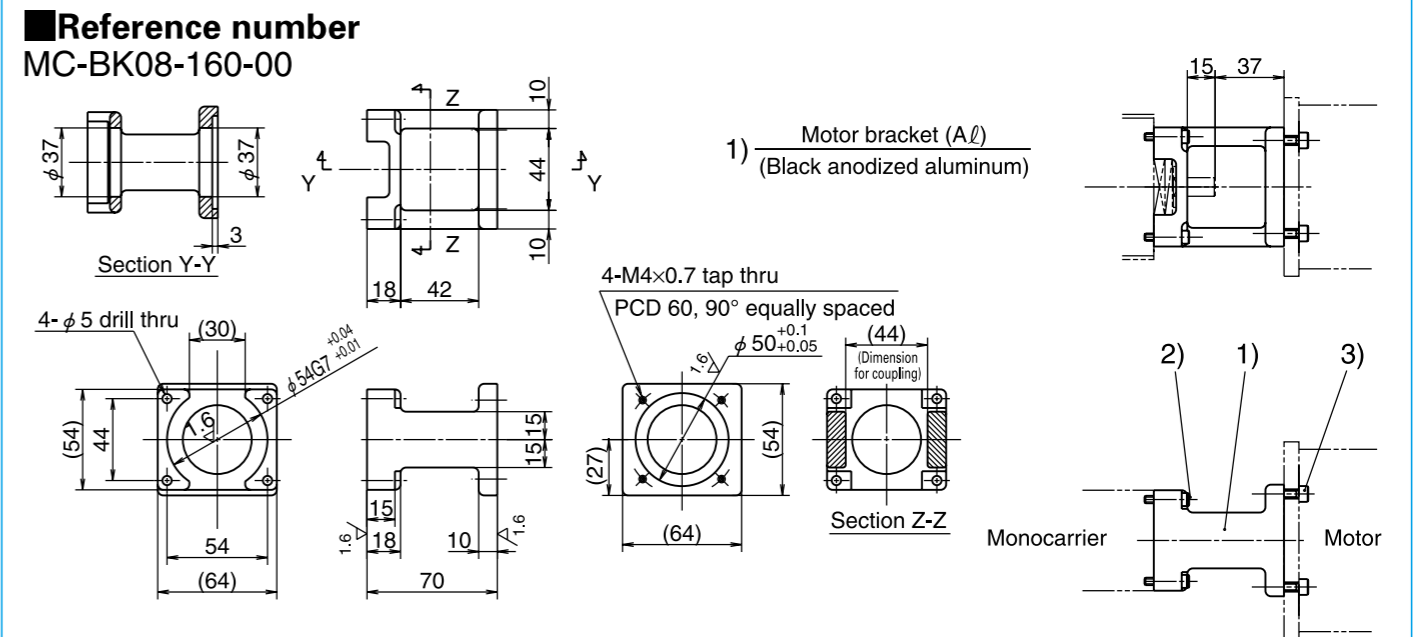

- 2) Hexagon socket head cap screw (M4, length 20)
- 3) Hexagon socket head cap screw (M4, length 14)

Notes: 1. Be sure to align centerlines when installing motor.
2. Be careful in the assembly orientation of bracket.
3. Because bracket is made by sand casting, external dimensions are for reference only.

Compatible motor	
Maker	Motor models
SANYO DENKI Co., Ltd.	P50B05005(50W), P50B05010(100W), P50B05020(200W)

Motor bracket for MCM08

Reference number
MC-BK08-170-00

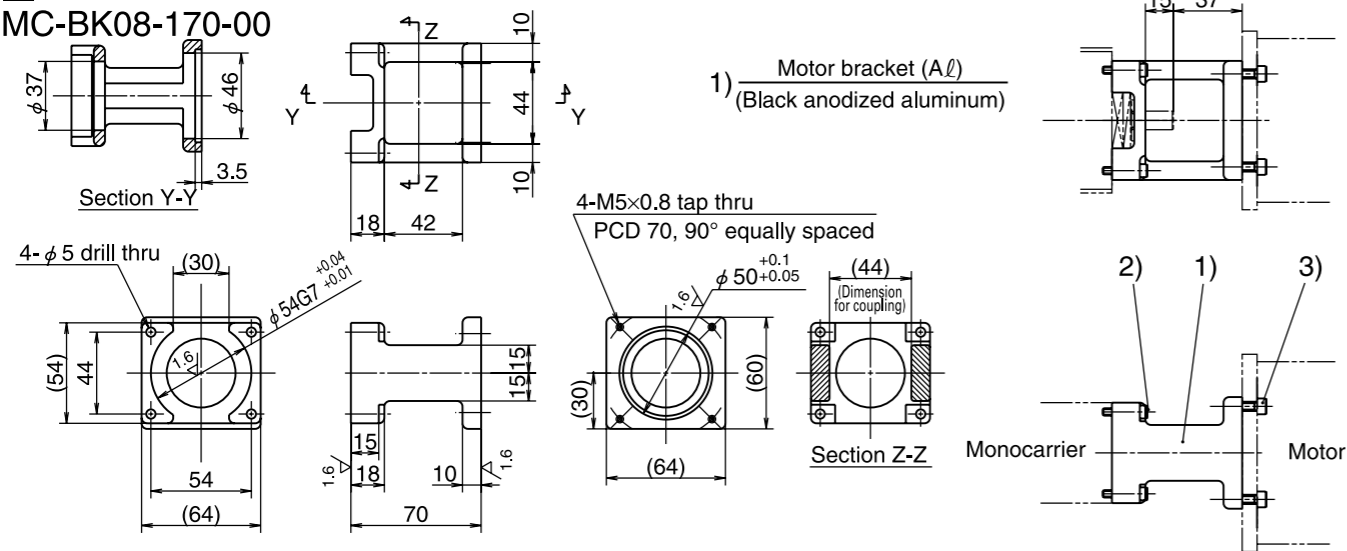

Notes: 1. Be sure to align centerlines when installing motor.
2. Be careful in the assembly orientation of bracket.
3. Because bracket is made by sand casting, external dimensions are for reference only.

Compatible motor	
Maker	Motor models
YASKAWA Electric Corp.	SGMJV-02A(200W), SGMJV-02A(200W), SGMJV-04A(400W), SGMJV-04A(400W)
Mitsubishi Electric Corp.	HF-KP23(200W), HF-MP23(200W), HF-KP43(400W), HF-MP43(400W)
	HC-KFS23(200W), HC-MFS23(200W), HC-KFS43(400W), HC-MFS43(400W)
OMRON Corp.	R88M-W20(200W), R88M-W40(400W)
SANYO DENKI Co., Ltd.	P30B06020(200W), P30B06040(400W)

- 2) Hexagon socket head cap screw (M4, length 20)
- 3) Hexagon socket head cap screw (M5, length 14)

Motor bracket for MCM08

Reference number
MC-BK08-250-00

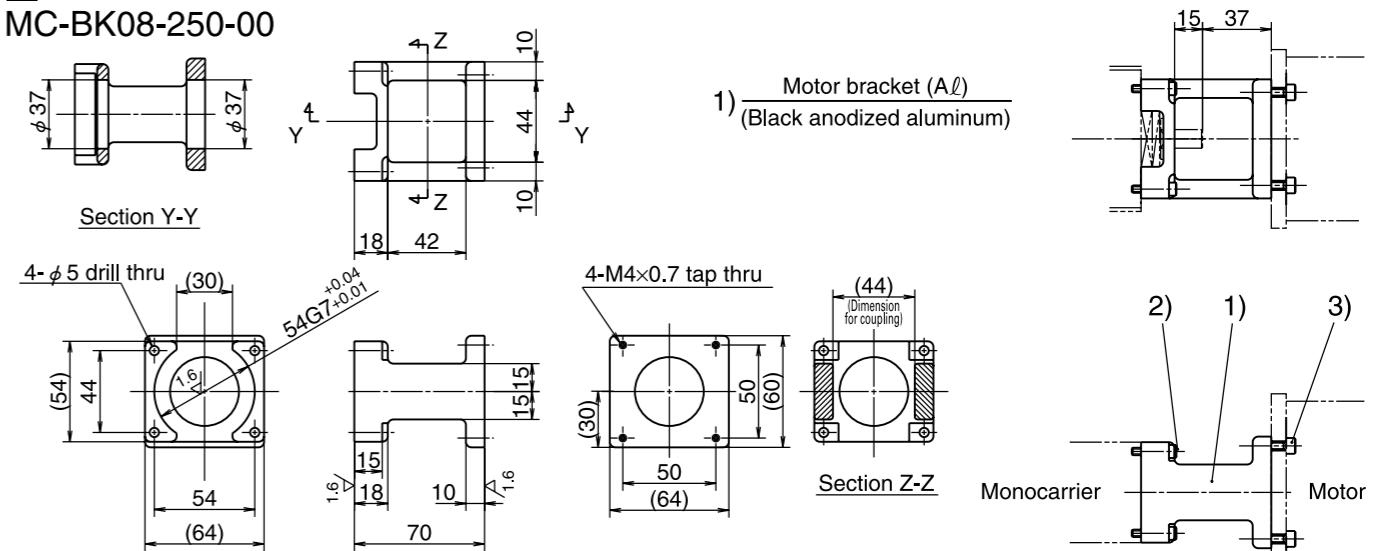

Notes: 1. Be sure to align centerlines when installing motor.
2. Be careful in the assembly orientation of bracket.
3. Because bracket is made by sand casting, external dimensions are for reference only.

Compatible motor	
Maker	Motor models
SANYO DENKI Co., Ltd.	PBM603xxx, PBM604xxx, 103F78xx
ORIENTAL MOTOR Co., Ltd.	AS66, ASC66, UPK56xx, PK56xx, CSK56x
	CFK56x, UFK56x

- 2) Hexagon socket head cap screw (M4, length 20)
- 3) Hexagon socket head cap screw (M4, length 14)

Motor bracket for MCM08

Reference number
MC-BK08-170-01

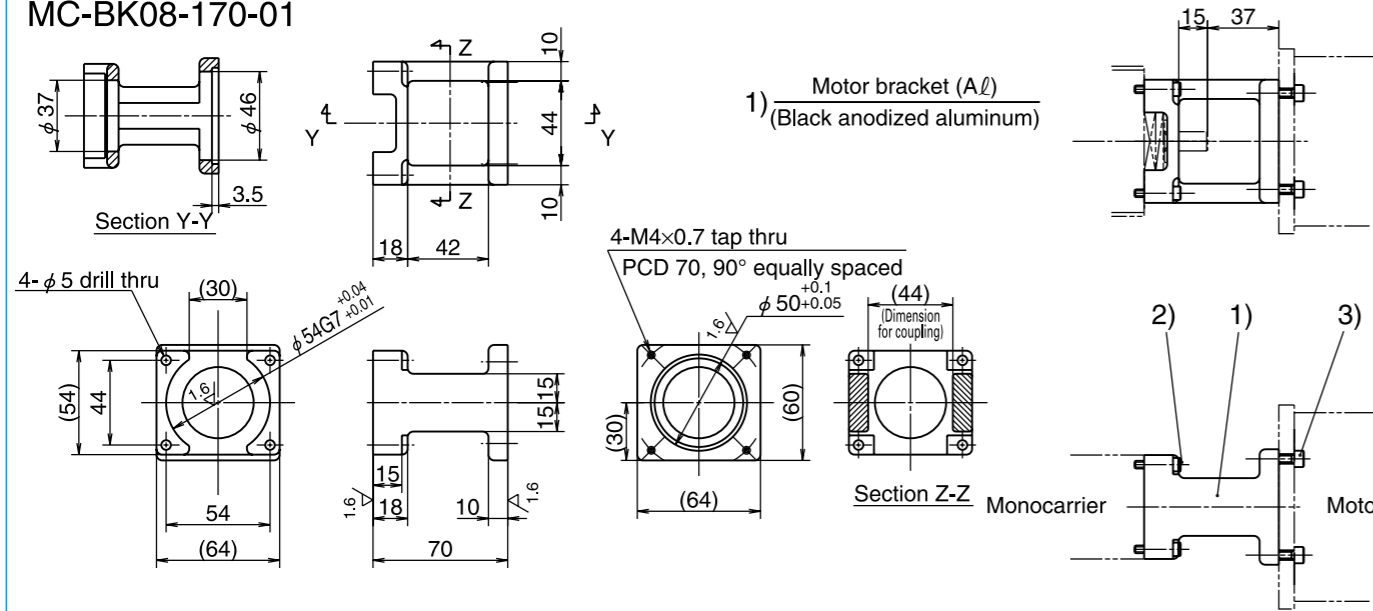

Notes: 1. Be sure to align centerlines when installing motor.
2. Be careful in the assembly orientation of bracket.
3. Because bracket is made by sand casting, external dimensions are for reference only.

Compatible motor	
Maker	Motor models
Panasonic Co., Ltd.	MSMD02(200W), MAMA02(200W), MSMD04(400W), MAMA04(400W)

- 2) Hexagon socket head cap screw (M4, length 20)
- 3) Hexagon socket head cap screw (M4, length 14)

Motor bracket for MCM08

Reference number
MC-BK08-190-00

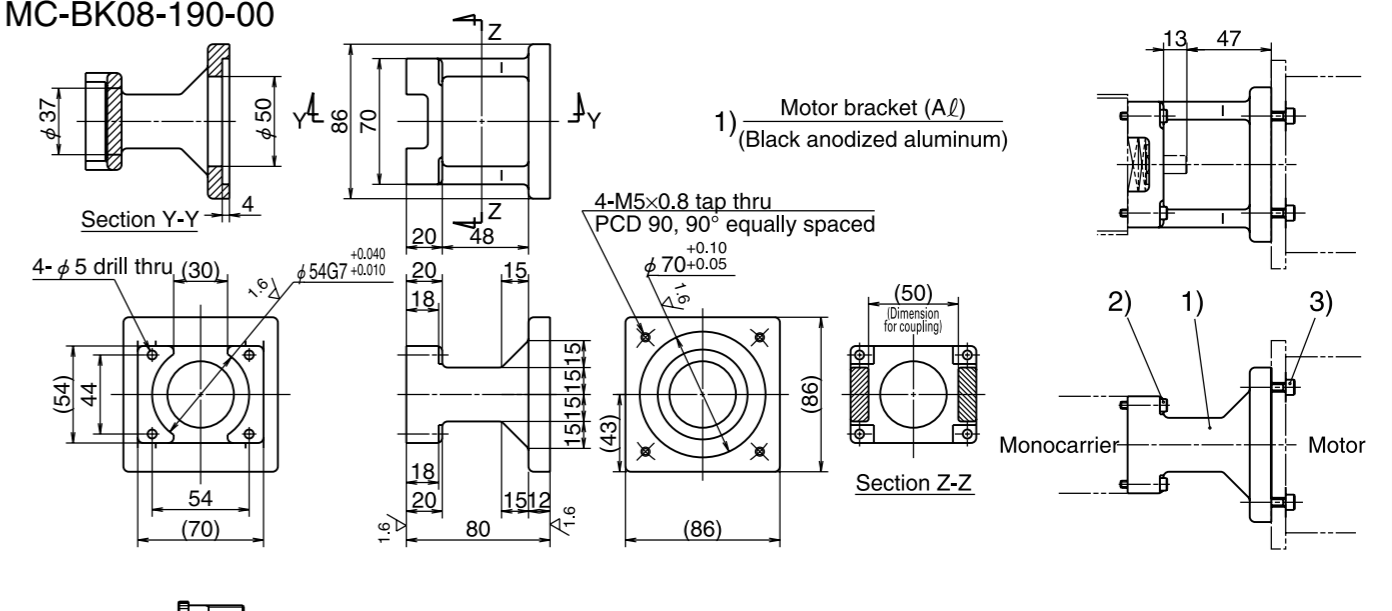

Notes: 1. Be sure to align centerlines when installing motor.
2. Be careful in the assembly orientation of bracket.
3. Because bracket is made by sand casting, external dimensions are for reference only.

Compatible motor	
Maker	Motor models
SANYO DENKI Co., Ltd.	P50B07020(200W), P50B07030(300W), P50B07040(400W)

- 2) Hexagon socket head cap screw (M4, length 22)
- 3) Hexagon socket head cap screw (M5, length 16)

Motor bracket for MCM08

Reference number
MC-BK08-270-00

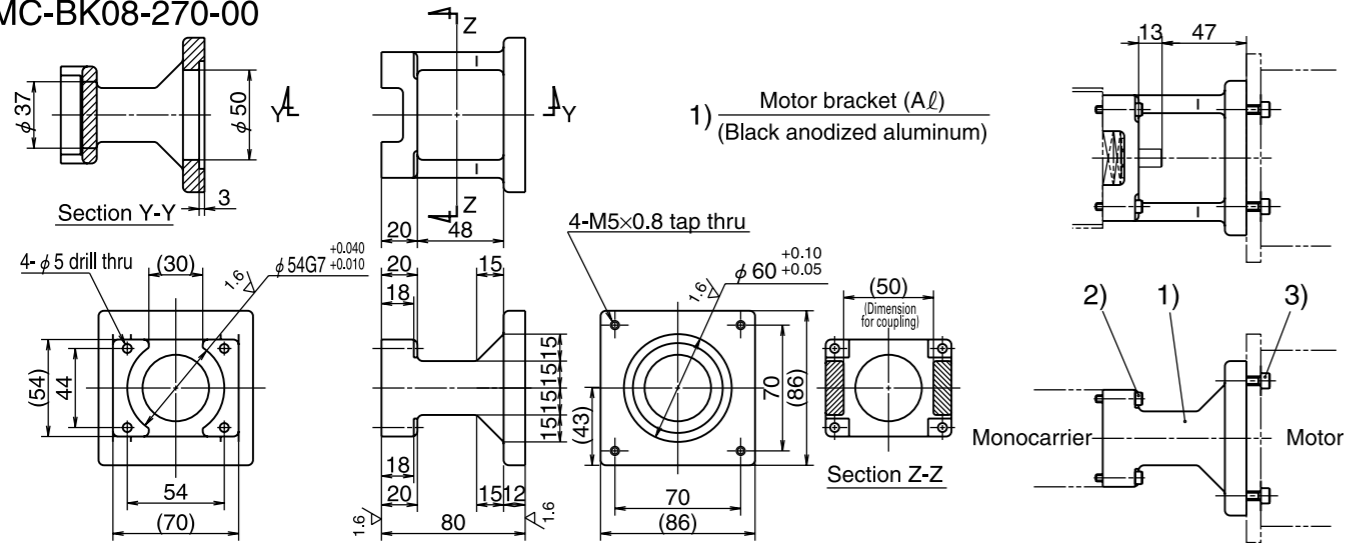

- 2) Hexagon socket head cap screw (M4, length 22)
- 3) Hexagon socket head cap screw (M5, length 16)

Notes: 1. Be sure to align centerlines when installing motor.
2. Be careful in the assembly orientation of bracket.
3. Because bracket is made by sand casting, external dimensions are for reference only.

Compatible motor	
Maker	Motor models
ORIENTAL MOTOR Co., Ltd.	AS98, UPK59x, PK59x CSK59x, CFK59x, UFK59x
SANYO DENKI Co., Ltd.	103F85xx

Motor bracket for MCM10

Reference number
MC-BK10-170-01

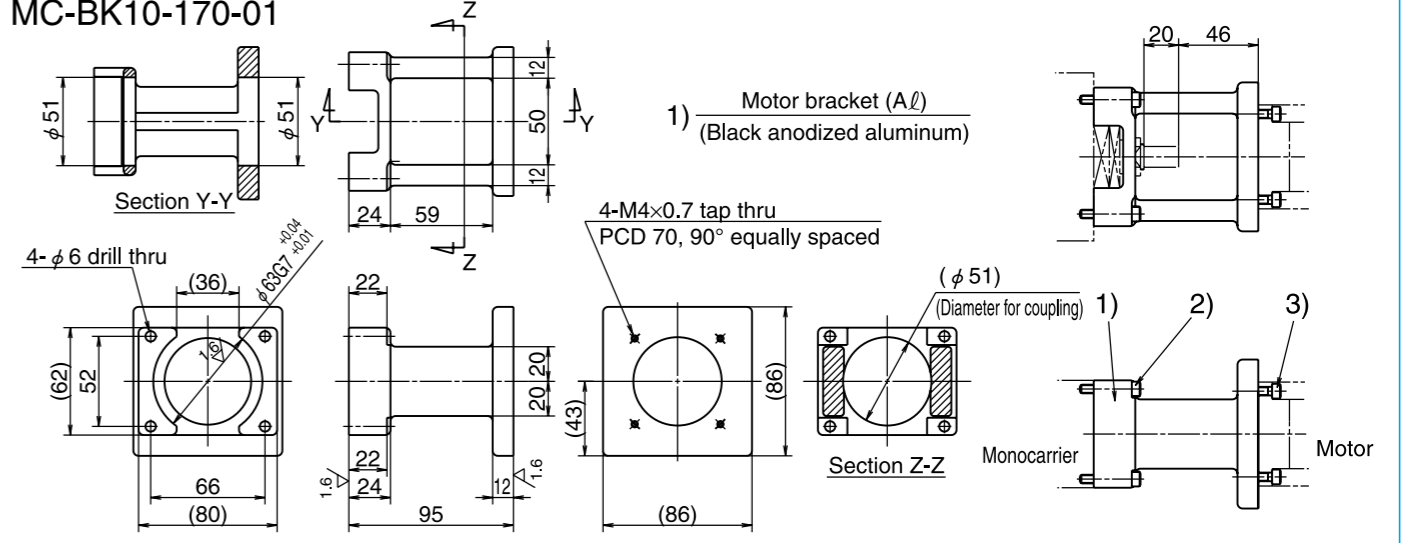

- 2) Hexagon socket head cap screw (M5, length 30)
- 3) Hexagon socket head cap screw (M4, length 16)

Notes: 1. Be sure to align centerlines when installing motor.
2. Be careful in the assembly orientation of bracket.
3. Because bracket is made by sand casting, external dimensions are for reference only.

Compatible motor	
Maker	Motor models
Panasonic Co., Ltd.	MSMD02(200W), MAMA02(200W), MSMD04(400W), MAMA04(400W)

Motor bracket for MCM10

Reference number
MC-BK10-170-00

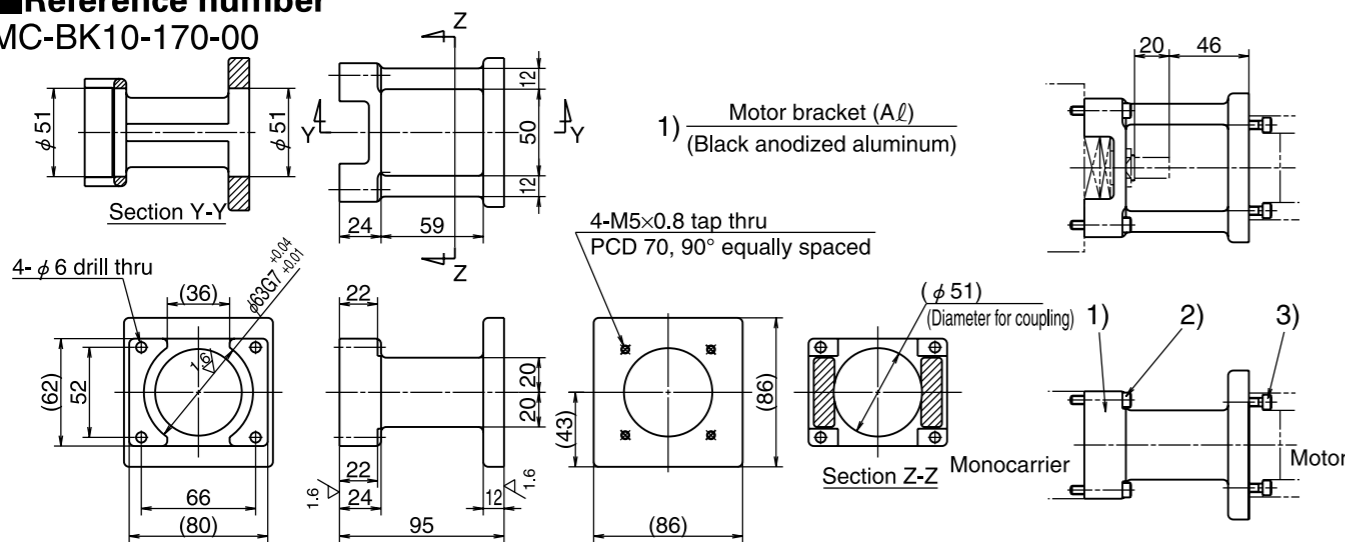

- 2) Hexagon socket head cap screw (M5, length 30)
- 3) Hexagon socket head cap screw (M5, length 16)

Notes: 1. Be sure to align centerlines when installing motor.
2. Be careful in the assembly orientation of bracket.
3. Because bracket is made by sand casting, external dimensions are for reference only.

Compatible motor	
Maker	Motor models
YASKAWA Electric Corp.	SGMJV-02A(200W), SGMJV-02A(200W), SGMJV-04A(400W), SGMJV-04A(400W) HF-KP23(200W), HF-MP23(200W), HF-KP43(400W), HF-MP43(400W)
Mitsubishi Electric Corp.	HC-KFS23(200W), HC-MFS23(200W), HC-KFS43(400W), HC-MFS43(400W)
OMRON Corp.	R88M-W20(200W), R88M-W40(400W)
SANYO DENKI Co., Ltd.	P30B06020(200W), P30B06040(400W)

Motor bracket for MCM10

Reference number
MC-BK10-190-00

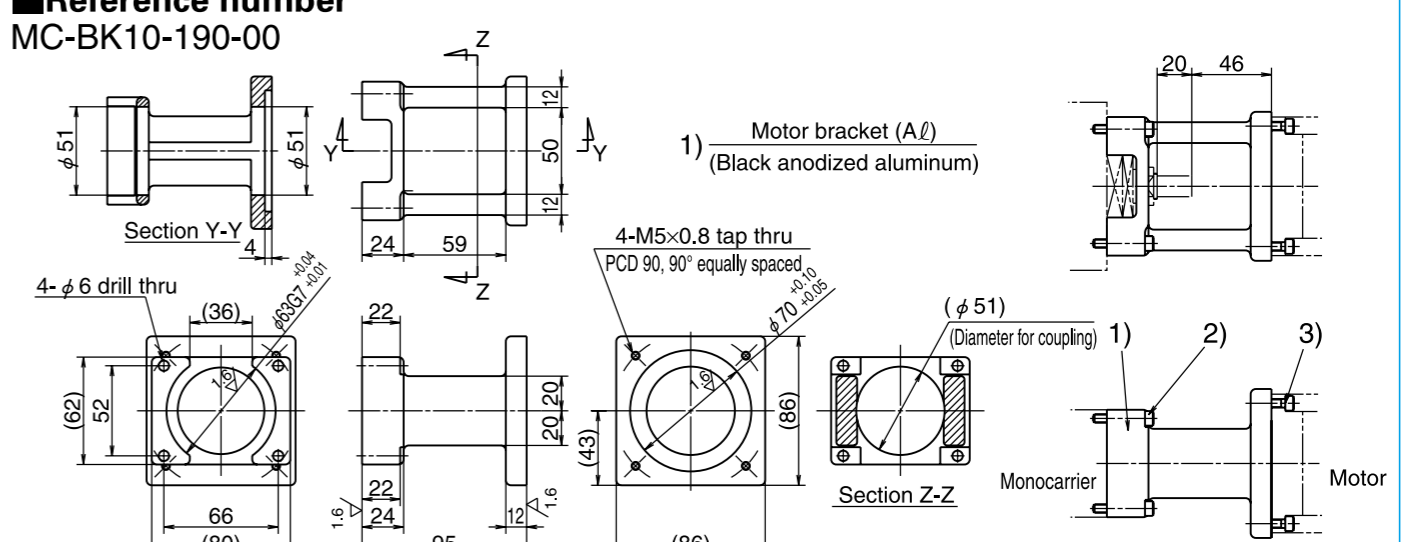

- 2) Hexagon socket head cap screw (M5, length 30)
- 3) Hexagon socket head cap screw (M5, length 16)

Notes: 1. Be sure to align centerlines when installing motor.
2. Be careful in the assembly orientation of bracket.
3. Because bracket is made by sand casting, external dimensions are for reference only.

Compatible motor	
Maker	Motor models
Panasonic Co., Ltd.	MSMD08(750W), MAMA08(750W)
SANYO DENKI Co., Ltd.	P50B07020(200W), P50B07030(300W), P50B07040(400W)

Motor bracket for MCM10

Reference number
MC-BK10-270-00

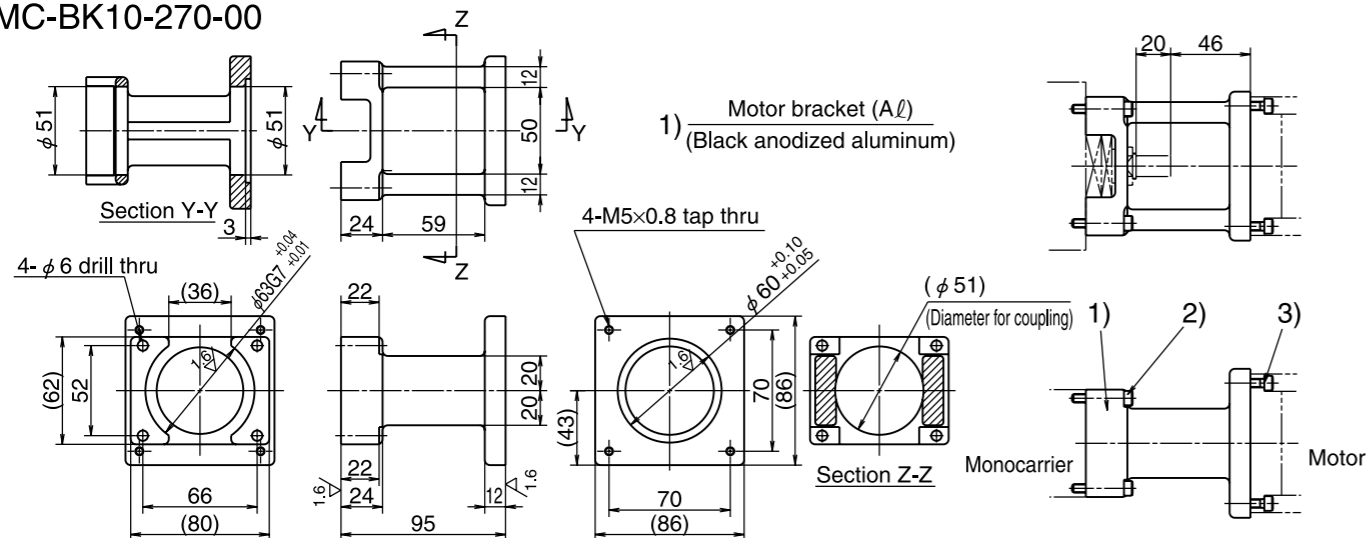

Notes: 1. Be sure to align centerlines when installing motor.
2. Be careful in the assembly orientation of bracket.
3. Because bracket is made by sand casting, external dimensions are for reference only.

Compatible motor	
Maker	Motor models
SANYO DENKI Co., Ltd.	103F85xx
ORIENTAL MOTOR Co., Ltd.	AS98, UPK59x, PK59x, CSK59x CFK59x, UFK59x

- 2) Hexagon socket head cap screw (M5, length 30)
- 3) Hexagon socket head cap screw (M5, length 18)

Motor Availability Table of Motor Bracket for MCM Series

Table 5

Model No.	Reference No. code	Motor bracket reference No.	Motor manufacturer	Stepping motor model No.	Wattage of AC servo motor												
					10	20	30	50	60	100	150	200	300	400	750		
MCM02	1	MC-BK02-128-00	YASKAWA Electric Corp.		SGMM-A1	SGMM-A2											
	2	MC-BK02-133-00	Mitsubishi Electric Corp.		HC-AQ013	HC-AQ023											
	3	MC-BK02-223-00	ORIENTAL MOTOR Co., Ltd.	PMU33/35 (5-phase) PMC33/35 (5-phase)													
MCM03	1	MC-BK03-146-00	YASKAWA Electric Corp.				SGMAH-A3	SGMJV-A5A SGMAV-A5A		SGMJV-01A SGMAV-01A	SGMAV-C2A						
			Mitsubishi Electric Corp.				HF-KP053 HF-MP053 HC-KFS053 HC-MFS053		HF-KP13 HF-MP13 HC-KFS13 HC-MFS13								
			OMRON Corp.				R88M-W03 R88M-W05		R88M-W10								
MCM05	2	MC-BK05-146-00	SANYO DENKI Co., Ltd.														
			Mitsubishi Electric Corp.					HF-KP053 HF-MP053 HC-KFS053 HC-MFS053		HF-KP13 HF-MP13 HC-KFS13 HC-MFS13							
			OMRON Corp.					R88M-W03 R88M-W05		R88M-W10							
MCM06	5	MC-BK06-170-00	YASKAWA Electric Corp.							SGMJV-02A SGMAV-02A		SGMJV-04A SGMAV-04A					
			Mitsubishi Electric Corp.					HF-KP23 HF-MP23 HC-KFS23 HC-MFS23		HF-KP43 HF-MP43 HC-KFS43 HC-MFS43							
			OMRON Corp.					R88M-W20 R88M-W40		R88M-W40							
MCM07	7	MC-BK06-250-00	SANYO DENKI Co., Ltd.	PBM603xxx, PBM604xxx													
			Mitsubishi Electric Corp.					HF-KP23 HF-MP23 HC-KFS23 HC-MFS23		HF-KP43 HF-MP43 HC-KFS43 HC-MFS43							
			OMRON Corp.					R88M-W20 R88M-W40		R88M-W40							

Model No.	Reference No. code	Motor bracket reference No.	Motor manufacturer	Stepping motor model No.	Wattage of AC servo motor												
					10	20	30	50	60	100	150	200	300	400	750		
MCM08	1	MC-BK08-145-00	Panasonic Co., Ltd.								MSMD01						
	2	MC-BK08-146-00	YASKAWA Electric Corp.								SGMJV-01A SGMAV-01A	SGMAV-C2A					
			Mitsubishi Electric Corp.								HF-KP13 HF-MP13 HC-KFS13 HC-MFS13						
			SANYO DENKI Co., Ltd.			P30B04003	P30B04005				P30B04010						
	3	MC-BK08-160-00	SANYO DENKI Co., Ltd.									P50B05010	P50B05020				
	4	MC-BK08-170-00	YASKAWA Electric Corp.										SGMJV-02A SGMAV-02A		SGMJV-04A SGMAV-04A		
			Mitsubishi Electric Corp.										HF-KP23 HF-MP23 HC-KFS23 HC-MFS23		HF-KP43 HF-MP43 HC-KFS43 HC-MFS43		
			OMRON Corp.										R88M-W20		R88M-W40		
SANYO DENKI Co., Ltd.												P30B06020		P30B06040			
5	MC-BK08-170-01	Panasonic Co., Ltd.										MSMD02 MAMA02		MSMD04 MAMA04			
6	MC-BK08-190-00	SANYO DENKI Co., Ltd.										P50B07020	P50B07030	P50B07040			
7	MC-BK08-250-00	SANYO DENKI Co., Ltd.	PBM603xxx, PBM604xxx														
		SANYO DENKI Co., Ltd.	103F78xx														
		ORIENTAL MOTOR Co., Ltd.	AS66, ASC66 UPK56x, PK56x CSK56x, CFK56x U FK56x														
8	MC-BK08-270-00	SANYO DENKI Co., Ltd.	103F85xx														
		ORIENTAL MOTOR Co., Ltd.	AS98 UPK59x, PK59x CSK59x, CFK59x U FK59x														
MCM10	1	MC-BK10-170-00	YASKAWA Electric Corp.										SGMJV-02A SGMAV-02A		SGMJV-04A SGMAV-04A		
			Mitsubishi Electric Corp.											HF-KP23 HF-MP23 HC-KFS23 HC-MFS23		HF-KP43 HF-MP43 HC-KFS43 HC-MFS43	
			OMRON Corp.											R88M-W20		R88M-W40	
			SANYO DENKI Co., Ltd.											P30B06020		P30B06040	
	2	MC-BK10-170-01	Panasonic Co., Ltd.										MSMD02 MAMA02		MSMD04 MAMA04		
	3	MC-BK10-190-00	Panasonic Co., Ltd.														MSMD08 MAMA08
			SANYO DENKI Co., Ltd.											P50B07020	P50B07030	P50B07040	
	4	MC-BK10-270-00	SANYO DENKI Co., Ltd.	103F85xx													
		ORIENTAL MOTOR Co., Ltd.	AS98 UPK59x, PK59x CSK59x, CFK59x U FK59x														



1-6 MCH Series

1-6.1 MCH Series Reference Number **73**
 Coding

1-6.2 MCH Series Dimension Table of
 Standard Products

MCL06 **74**

MCH06 **75**

MCH09 **77**

MCH10 **79**

1-6.3 MCH Series Accessories

1-6.3.1 Sensor Unit **81**

1-6.3.2 Cover Unit **83**

1-6.3.3 Intermediate Plate for Motor **87**

MCH Series

1-6 MCH Series

1-6. 1 MCH Series Reference Number Coding

[Body]
Example: MCH06040H10K(B2)

Monocarrier

H Type: MCH Series
 L Type: MCH Series low profile rail (only for 06 size)

Nominal size (rail width, Unit: 10mm)

Stroke (Unit: 10mm)

Accuracy grade (H, high grade; P, precision grade)

*1
 NSK management number (0 or 2)
 Grease specification: B (LG2) (See page 140.)
 Slider specification K: Single slider
 D: Double slider (See page 14.)
 Ball screw lead (mm)

*1 : These two code fields are added when non-standard grease is used.

14th digit is control No. of NSK. Customers cannot specify a number. See the pages of each nominal number for details.

[With Accessories]
Example: MCS06040H10K02K000

S: With MCH Accessories
 R: With MCL Accessories

NSK management number
 Sensor unit
 Cover unit
 Intermediate plate for motor

Note: Option parts are available separately.

Table 1 Sensor unit (See page 81.)

Reference No. code	Specification	Reference No.
0	N/A	—
1	Proximity switch (Normally close contact 3 pieces)	MC—SRHxx—10
2	Proximity switch (Normally open contact 3 pieces)	MC—SRHxx—11
3	Proximity switch (Normally open contact 1 piece, Normally close contact 2 pieces)	MC—SRHxx—12
4	Photo sensor 3 pieces	MC—SRHxx—13

Notes: 1. xx: Nominal size
 2. Sensor rail is not included in a sensor unit. If you require the rail, please specify upon ordering. (See page 81 to 82.)

Table 2 Cover unit (See page 83 to 85.)

Reference No. code	Specification	Reference No.
0	N/A	—
1	For single slider	MC—HVxxxx—00
	For double slider	MC—HVxxxxD00

Note: xxxx; Nominal size and stroke number

Table 3 Intermediate plate for motor (See page 87 to 90.)

Reference No. code	Model No.		
	MCH06 (MCL06)	MCH09	MCH10
0	N/A	N/A	N/A
1	MC-BKH06-145-00	MC-BKH09-145-00	MC-BKH10-170-00
2	MC-BKH06-146-00	MC-BKH09-146-00	MC-BKH10-170-01
3	MC-BKH06-231-00	MC-BKH09-170-00	MC-BKH10-190-00
4	MC-BKH06-250-00	MC-BKH09-170-01	MC-BKH10-190-01
5	—	MC-BKH09-231-00	MC-BKH10-250-00
6	—	MC-BKH09-250-00	MC-BKH10-270-00

N/A: Not applicable

1-6. 2 MCH Series Dimension Table of Standard Products

MCL06

Accuracy grade: High grade (H)

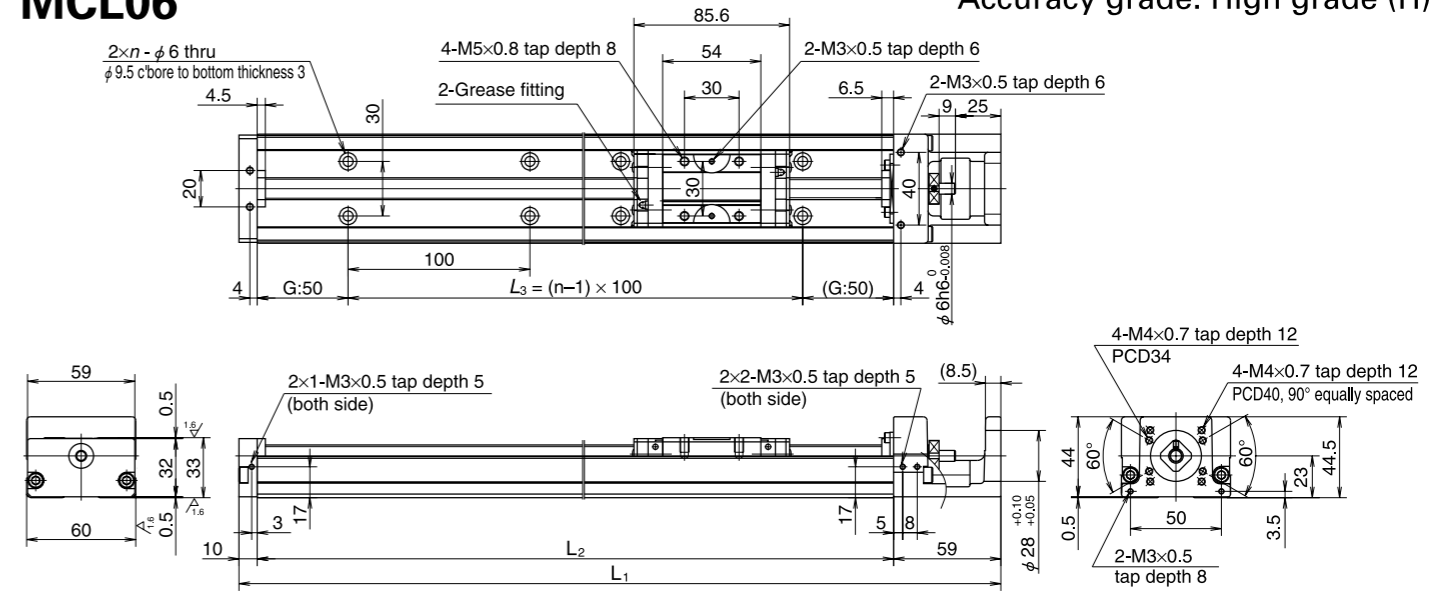

- Rail of MCL 06 is made lighter than that of MCH 06 by lowering rail height. Weight ratio between MCH 06 and MCL 06 is 5 to 4.
- Double slider specification is also available for MCL 06.
- Combinations of stroke and ball screw lead of MCL 06 are the same as those of MCH 06.

Dimension of MCL06 (Single slider)

Reference No.	Nominal stroke (mm)	Stroke limit (mm) (without K1)	Ball screw lead (mm)	Body length (mm)				Inertia x 10 ⁶ (kg · m ²)	Mass (kg)
				L ₁	L ₂	L ₃	n		
◇MCL06005H05K02	50	53	5	219	150	100	2	2.38	1.0
◇MCL06005H10K02		(65)	10					3.45	
MCL06010H05K02	100	103	5	269	200	100	2	3.17	1.3
MCL06010H10K02		(115)	10					4.12	
MCL06020H05K02	200	203	5	369	300	200	3	4.51	1.9
MCL06020H10K02		(215)	10					5.46	
MCL06030H10K02	300	303	10	469	400	300	4	6.80	2.6
MCL06030H20K02		(315)	20					10.6	
MCL06040H10K02	400	403	10	569	500	400	5	8.13	3.2
MCL06040H20K02		(415)	20					11.9	
MCL06050H10K02	500	503	10	669	600	500	6	9.47	3.9
MCL06050H20K02		(515)	20					13.3	

Notes: 1. Dimension G is 25 for items marked with ◇.
 2. The nominal number in the above table is for high-grade grease specifications. In the case of other specifications, see the following table for the 13th and 14th digits.

Coding for columns 13 and 14

Grease	High-grade	Precision-grade	Monocarrier dynamic torque specification (N · cm)		
Standard	02	(None)	Ball screw lead (mm)	5	1.0 – 4.8
LG2	B2	B0		10	1.1 – 5.8
				20	1.6 – 7.9

- Notes:
- Frictional resistance of NSK K1 is included in dynamic torque in table.
 - Grease is packed into ball screw, linear guide parts and support unit.
 - Consult NSK for life estimates under large moment loads.

Basic load rating

Lead ℓ (mm)	Shaft dia d (mm)	Basic dynamic load rating (N)				Basic static load rating (N)		Support unit load limit (N)
		Ball screw C _a	Linear guides C	Support unit C _a	Rated running distance L _a (km)	Ball screw C _{0a}	Linear guides C ₀	
5	φ 12	3 760	22 800	4 400	5	6 310	16 300	1 450
10		2 420	18 100		10	3 790		
20		2 420	14 400		20	3 790		

Basic static moment load of linear guide

Slider	Basic static moment load (N · m)		
	Rolling M _{RO}	Pitching M _{PO}	Yawing M _{YO}
Single	335	133	133

MCH06

Accuracy grade: High grade (H)

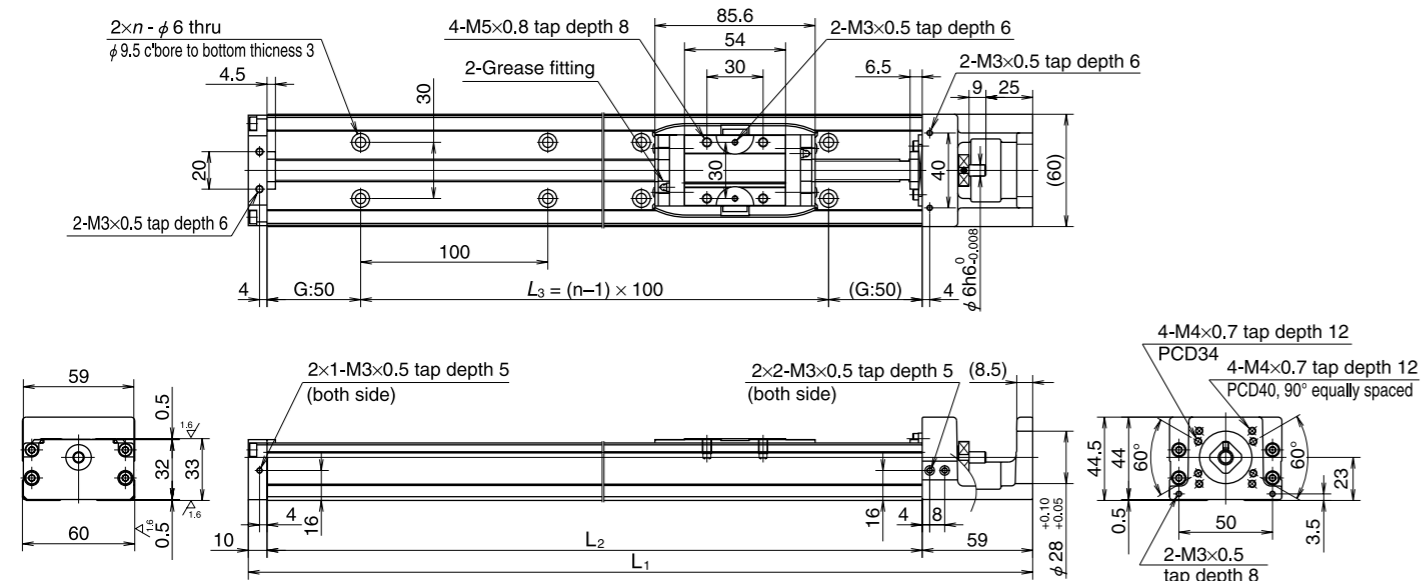

Dimension of MCH06 (Single slider)

Reference No.	Nominal stroke (mm)	Stroke limit (mm) (without K1)	Ball screw lead (mm)	Body length (mm)				Inertia $\times 10^{-6}(\text{kg} \cdot \text{m}^2)$	Mass (kg)
				L ₁	L ₂	L ₃	n		
◇ MCH06005H05K02	50	53 (65)	5	219	150	100	2	2.38	1.8
◇ MCH06005H10K02			10					3.45	
◇ MCH06005H20K02			20					7.25	
MCH06010H05K02	100	103 (115)	5	269	200	100	2	3.17	2.2
MCH06010H10K02			10					4.12	
MCH06010H20K02			20					7.92	
MCH06020H05K02	200	203 (215)	5	369	300	200	3	4.51	3.0
MCH06020H10K02			10					5.46	
MCH06020H20K02			20					9.26	
MCH06030H05K02	300	303 (315)	5	469	400	300	4	5.85	3.7
MCH06030H10K02			10					6.80	
MCH06030H20K02			20					10.6	
MCH06040H05K02	400	403 (415)	5	569	500	400	5	7.18	4.5
MCH06040H10K02			10					8.13	
MCH06040H20K02			20					11.9	
MCH06050H05K02	500	503 (515)	5	669	600	500	6	8.52	5.2
MCH06050H10K02			10					9.47	
MCH06050H20K02			20					13.3	

Notes: 1. Dimension G is 25 for items marked with ◇.

2. The nominal number in the above table is for high-grade grease specifications. In the case of other specifications, see the following table for the 13th and 14th digits.

Coding for columns 13 and 14

Grease	High-grade	Precision-grade	Monocarrier dynamic torque specification (N · cm)	
Standard	O2	(None)	Ball screw lead (mm)	5 1.0 – 4.8
LG2	B2	B0		10 1.1 – 5.8
				20 1.6 – 7.9

Notes:

- Frictional resistance of NSK K1 is included in dynamic torque in table.
- Grease is packed into ball screw, linear guide parts and support unit.
- Consult NSK for life estimates under large moment loads.

Basic load rating

Lead l (mm)	Shaft dia d (mm)	Basic dynamic load rating (N)				Basic static load rating (N)		Support unit load limit (N)
		Ball screw C_a	Linear guides C	Support unit C_a	Rated running distance L_a (km)	Ball screw C_{0a}	Linear guides C_0	
5	φ 12	3 760	22 800	4 400	5	6 310	16 300	1 450
10		2 420	18 100		10	3 790		
20		2 420	14 400		20	3 790		

Basic static moment load of linear guide

Slider	Basic static moment load (N · m)		
	Rolling M_{RO}	Pitching M_{PO}	Yawing M_{YO}
Single	335	133	133

MCH06 (Double slider)

Accuracy grade: High grade (H)

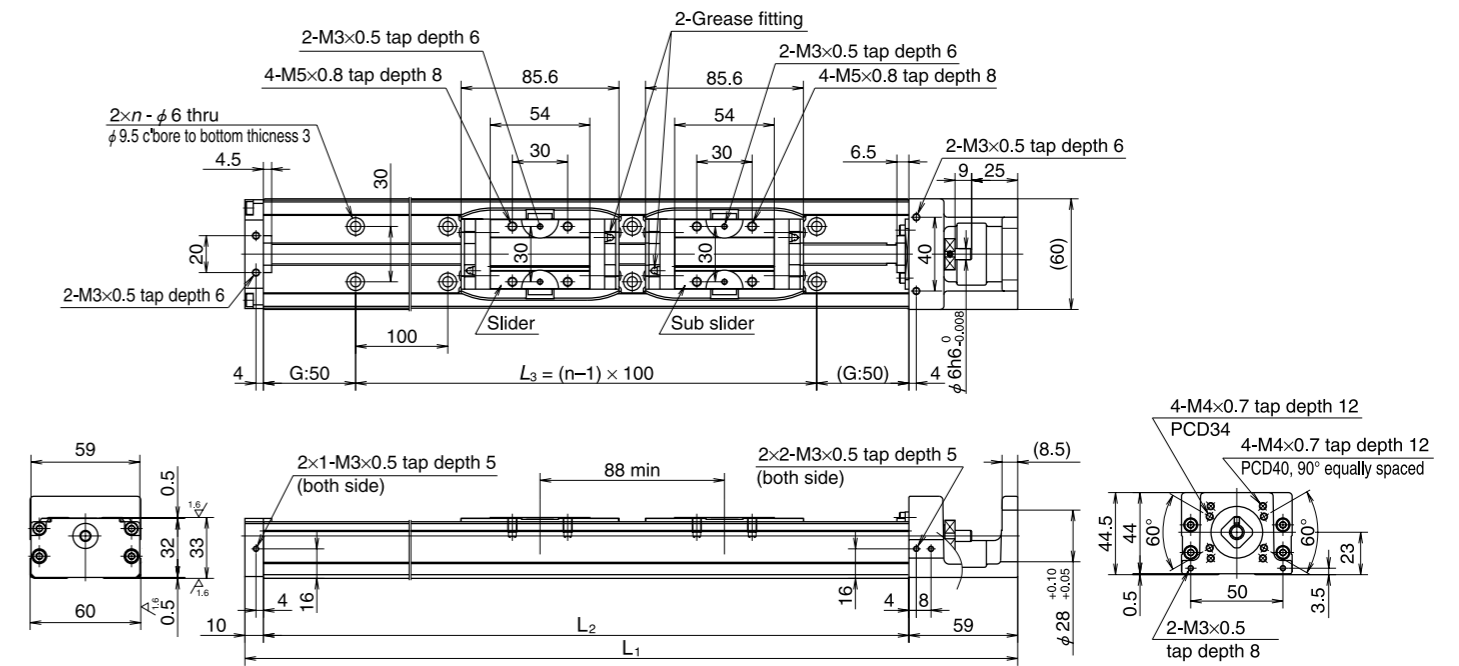

Dimension of MCH06 (Double slider)

Reference No.	Nominal stroke (mm)	Stroke limit (mm) (without K1)	Ball screw lead (mm)	Body length (mm)				Inertia $\times 10^{-6}(\text{kg} \cdot \text{m}^2)$	Mass (kg)
				L ₁	L ₂	L ₃	n		
MCH06010H05D02	100	115 (139)	5	369	300	200	3	4.82	3.5
MCH06010H10D02			10					6.72	
MCH06020H05D02	200	215 (239)	5	469	400	300	4	8.06	4.2
MCH06020H10D02			10					15.7	
MCH06030H05D02	300	315 (339)	5	569	500	400	5	9.40	5.0
MCH06030H10D02			10					17.0	
MCH06040H10D02	400	415 (439)	10	669	600	500	6	10.7	5.7
MCH06040H20D02			20					18.3	

Note: The nominal number in the above table is for high-grade grease specifications. In the case of other specifications, see the following table for the 13th and 14th digits.

Coding for columns 13 and 14

Grease	High-grade	Precision-grade	Monocarrier dynamic torque specification (N · cm)	
Standard	O2	(None)	Ball screw lead (mm)	5 1.2 – 5.2
LG2	B2	B0		10 1.5 – 9.6
				20 2.3 – 11.8

Notes:

- Frictional resistance of NSK K1 is included in dynamic torque in table.
- Grease is packed into ball screw, linear guide parts and support unit.
- Consult NSK for life estimates under large moment loads.

Basic load rating

Lead l (mm)	Shaft dia d (mm)	Basic dynamic load rating (N)				Basic static load rating (N)		Support unit load limit (N)
		Ball screw C_a	Linear guides C	Support unit C_a	Rated running distance L_a (km)	Ball screw C_{0a}	Linear guides C_0	
5	φ 12	3 760	22 800	4 400	5	6 310	16 300	1 450
10		2 420	18 100		10	3 790		
20		2 420	14 400		20	3 790		

Basic static moment load of linear guide

Slider	Basic static moment load (N · m)		
	Rolling M_{RO}	Pitching M_{PO}	Yawing M_{YO}
Double	770	730	730

MCH09

Accuracy grade: High grade (H)

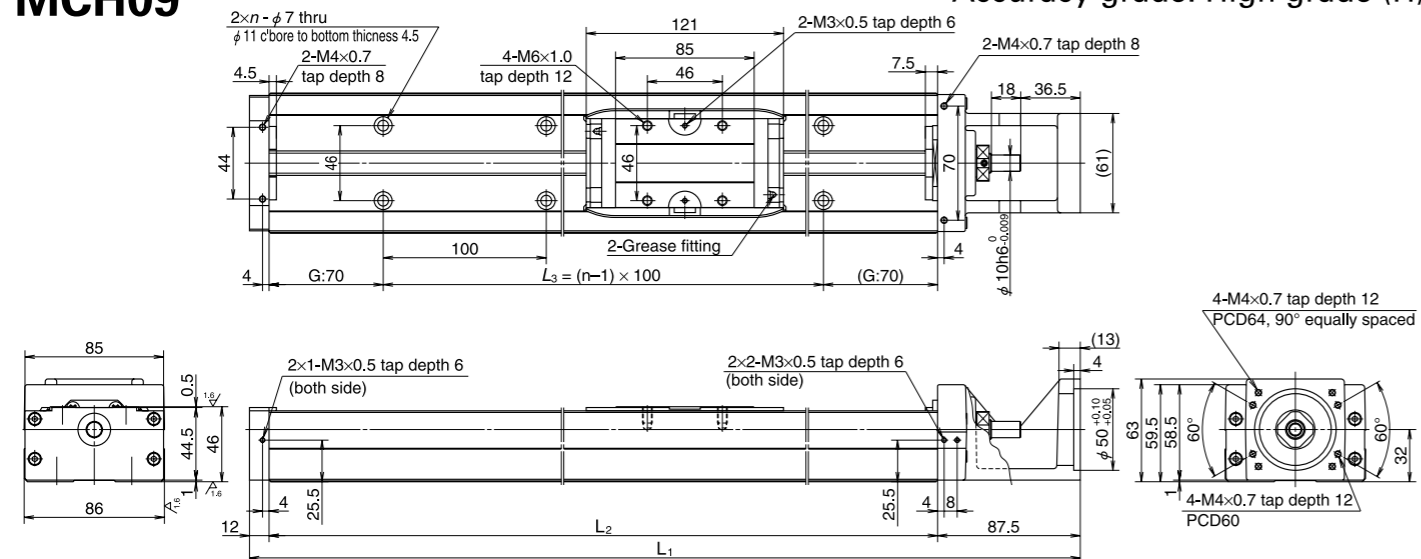

Dimension of MCH09 (Single slider)

Reference No.	Nominal stroke (mm)	Stroke limit (mm) (without K1)	Ball screw lead (mm)	Body length (mm)				Inertia $\times 10^{-6}(\text{kg} \cdot \text{m}^2)$	Mass (kg)
				L_1	L_2	L_3	n		
MCH09010H05K02	100	107 (121)	5	339.5	240	100	2	9.2	5.0
MCH09010H10K02			10					10.7	
MCH09010H20K02			20					16.8	
MCH09020H05K02	200	207 (221)	5	439.5	340	200	3	12.4	6.5
MCH09020H10K02			10					13.9	
MCH09020H20K02			20					20.0	
MCH09030H05K02	300	307 (321)	5	539.5	440	300	4	15.6	8.1
MCH09030H10K02			10					17.1	
MCH09030H20K02			20					23.2	
MCH09040H05K02	400	407 (421)	5	639.5	540	400	5	18.8	9.7
MCH09040H10K02			10					20.3	
MCH09040H20K02			20					26.4	
MCH09050H05K02	500	507 (521)	5	739.5	640	500	6	22.0	11
MCH09050H10K02			10					23.5	
MCH09050H20K02			20					29.6	
MCH09060H05K02	600	607 (621)	5	839.5	740	600	7	25.2	13
MCH09060H10K02			10					26.7	
MCH09060H20K02			20					32.8	
MCH09070H05K02	700	707 (721)	5	939.5	840	700	8	28.4	14.5
MCH09070H10K02			10					30.0	
MCH09070H20K02			20					36.0	
MCH09080H05K02	800	807 (821)	5	1 039.5	940	800	9	31.6	16
MCH09080H10K02			10					33.2	
MCH09080H20K02			20					39.2	

Note: The nominal number in the above table is for high-grade grease specifications. In the case of other specifications, see the following table for the 13th and 14th digits.

Coding for columns 13 and 14

Grease	High-grade	Precision-grade	Monocarrier dynamic torque specification (N · cm)	
Standard	O2	(None)	Ball screw lead (mm)	5 1.0 – 5.9
LG2	B2	B0		10 2.0 – 7.8
				20 2.0 – 10.8

Notes:

- Frictional resistance of NSK K1 is included in dynamic torque in table.
- Grease is packed into ball screw, linear guide parts and support unit.
- Consult NSK for life estimates under large moment loads.

Basic load rating

Lead l (mm)	Shaft dia d (mm)	Basic dynamic load rating (N)				Basic static load rating (N)		Support unit load limit (N)
		Ball screw C_a	Linear guides C	Support unit C_a	Rated running distance L_a (km)	Ball screw C_{0a}	Linear guides C_0	
5	$\phi 15$	7 070	40 600	7 100	5	12 800	3 040	
10		7 070	32 200		10	12 800		
20		4 560	25 500		20	7 730		

Basic static moment load of linear guide

Slider	Basic static moment load (N · m)		
	Rolling M_{RO}	Pitching M_{PO}	Yawing M_{YO}
Single	890	385	385

MCH09 (Double slider)

Accuracy grade: High grade (H)

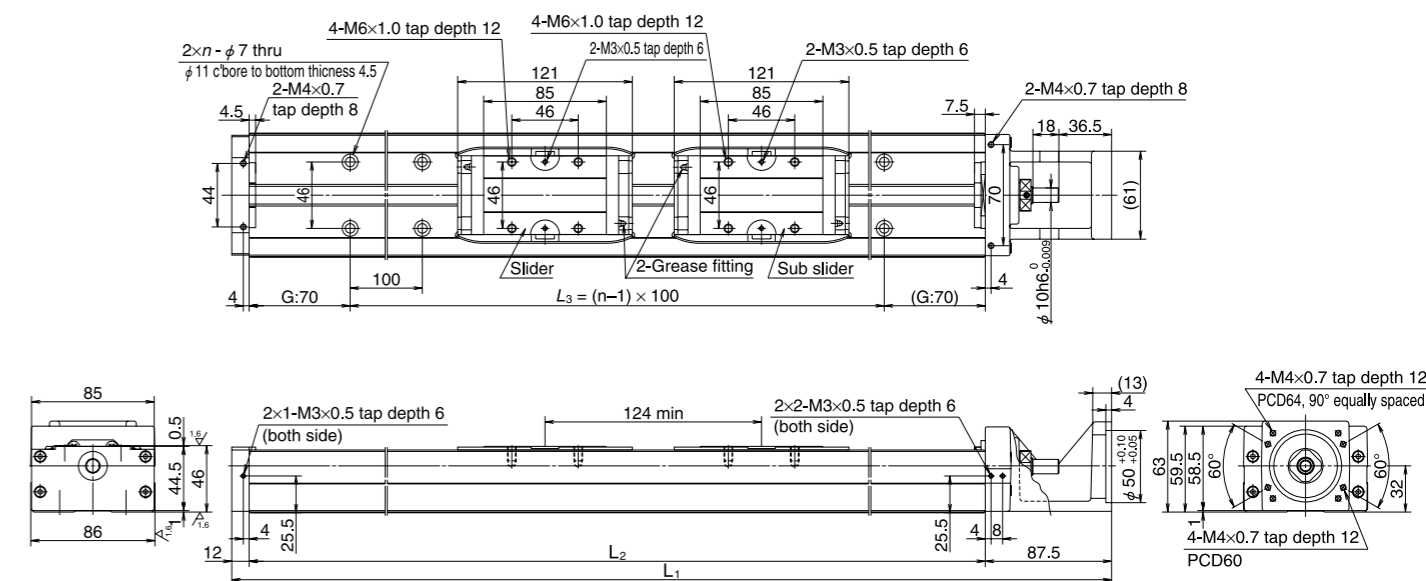

Dimension of MCH09 (Double slider)

Reference No.	Nominal stroke (mm)	Stroke limit (mm) (without K1)	Ball screw lead (mm)	Body length (mm)				Inertia $\times 10^{-6}(\text{kg} \cdot \text{m}^2)$	Mass (kg)
				L_1	L_2	L_3	n		
MCH09015H05D02	150	183 (211)	5	539.5	440	300	4	16.1	8.9
MCH09015H10D02			10					19.2	
MCH09025H05D02	250	283 (311)	5	639.5	540	400	5	19.3	11
MCH09025H10D02			10					22.4	
MCH09035H05D02	350	383 (411)	5	739.5	640	500	6	22.5	12
MCH09035H10D02			10					25.6	
MCH09045H10D02	450	483 (511)	10	839.5	740	600	7	28.8	14
MCH09045H20D02			20					40.9	
MCH09065H10D02	650	683 (711)	10	1 039.5	940	800	9	35.2	17
MCH09065H20D02			20					47.3	

Note: The nominal number in the above table is for high-grade grease specifications. In the case of other specifications, see the following table for the 13th and 14th digits.

Coding for columns 13 and 14

Grease	High-grade	Precision-grade	Monocarrier dynamic torque specification (N · cm)	
Standard	O2	(None)	Ball screw lead (mm)	5 1.5 – 7.0
LG2	B2	B0		10 2.5 – 10.8
				20 4.0 – 17.2

Notes:

- Frictional resistance of NSK K1 is included in dynamic torque in table.
- Grease is packed into ball screw, linear guide parts and support unit.
- Consult NSK for life estimates under large moment loads.

Basic load rating

Lead l (mm)	Shaft dia d (mm)	Basic dynamic load rating (N)				Basic static load rating (N)		Support unit load limit (N)
		Ball screw C_a	Linear guides C	Support unit C_a	Rated running distance L_a (km)	Ball screw C_{0a}	Linear guides C_0	
5	$\phi 15$	7 070	40 600	7 100	5	12 800	3 040	
10		7 070	32 200		10	12 800		
20		4 560	25 500		20	7 730		

Basic static moment load of linear guide

Slider	Basic static moment load (N · m)		
	Rolling M_{RO}	Pitching M_{PO}	Yawing M_{YO}
Double	1 780	2 070	2 070

MCH10

Accuracy grade: High grade (H)

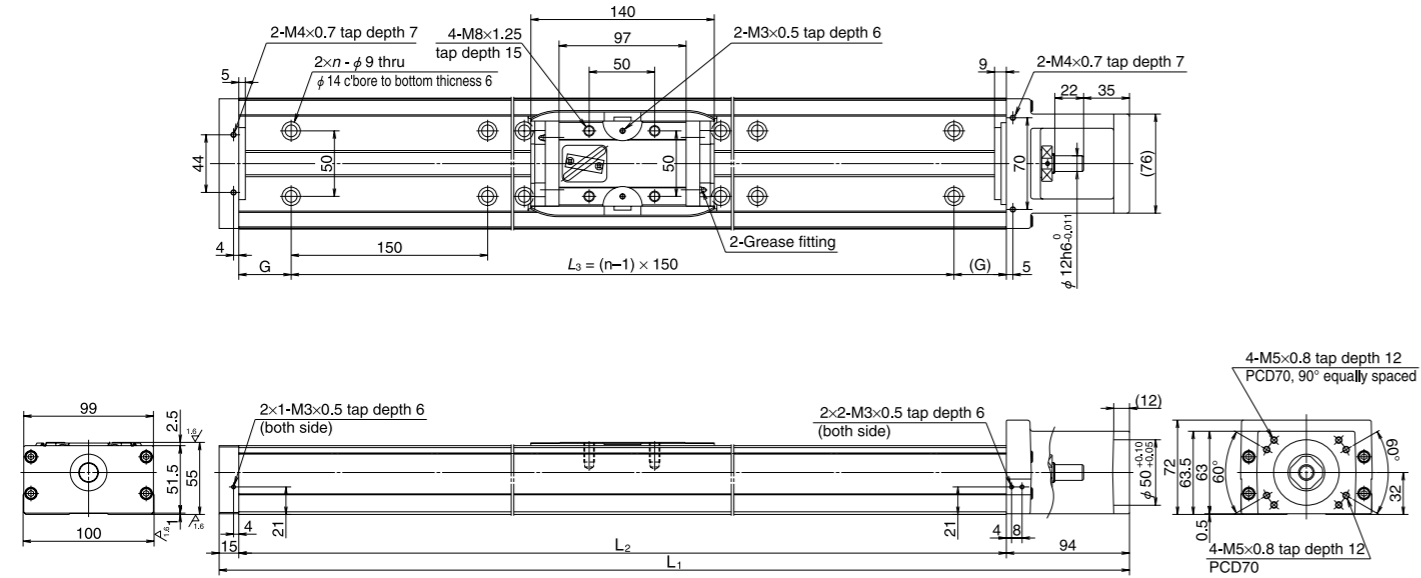

Dimension of MCH10 (Single slider)

Reference No.	Nominal stroke (mm)	Stroke limit (mm) (without K1)	Ball screw lead (mm)	Body length (mm)					Inertia × 10 ⁻⁶ (kg · m ²)	Mass (kg)
				L ₁	L ₂	G	L ₃	n		
MCH10010H10K02	100	126	10	389	280	65	150	2	33.2	7.3
MCH10010H20K02		(142)	20						41.1	
MCH10020H10K02	200	226	10	489	380	40	300	3	43.4	9.5
MCH10020H20K02		(242)	20						51.3	
MCH10030H10K02	300	326	10	589	480	15	450	4	53.7	12
MCH10030H20K02		(342)	20						61.6	
MCH10040H10K02	400	426	10	689	580	65	450	4	62.4	14
MCH10040H20K02		(442)	20						71.8	
MCH10050H10K02	500	526	10	789	680	40	600	5	74.7	16
MCH10050H20K02		(542)	20						82.3	
MCH10060H10K02	600	626	10	889	780	15	750	6	84.9	19
MCH10060H20K02		(642)	20						92.5	
MCH10070H10K02	700	726	10	989	880	65	750	6	95.1	21
MCH10070H20K02		(742)	20						103	
MCH10080H10K02	800	826	10	1 089	980	40	900	7	105	23
MCH10080H20K02		(842)	20						113	
MCH10090H10K02	900	926	10	1 189	1 080	15	1 050	8	116	25
MCH10090H20K02		(942)	20						123	
MCH10100H10K02	1 000	1 026	10	1 289	1 180	65	1 050	8	126	27
MCH10100H20K02		(1 042)	20						133	
MCH10110H10K02	1 100	1 126	10	1 389	1 280	40	1 200	9	136	29
MCH10110H20K02		(1 142)	20						143	
MCH10120H10K02	1 200	1 226	10	1 489	1 380	15	1 350	10	146	32
MCH10120H20K02		(1 242)	20						154	

Note: The nominal number in the above table is for high-grade grease specifications. In the case of other specifications, see the following table for the 13th and 14th digits.

Coding for columns 13 and 14

Grease	High-grade	Precision-grade	Monocarrier dynamic torque specification (N · cm)	
Standard	02	(None)	Ball screw lead	10 2.7 – 10.8
LG2	B2	B0	(mm)	20 3.1 – 12.7

- Notes:
- Frictional resistance of NSK K1 is included in dynamic torque in table.
 - Grease is packed into ball screw, linear guide parts and support unit.
 - Consult NSK for life estimates under large moment loads.

Basic load rating

Lead ℓ (mm)	Shaft dia d (mm)	Basic dynamic load rating (N)				Basic static load rating (N)		Support unit load limit (N)
		Ball screw C _a	Linear guides C	Support unit C _a	Rated running distance L _a (km)	Ball screw C _{0a}	Linear guides C ₀	
10	φ20	11 000	44 600	7 600	10	21 100	42 000	3 380
20		7 060	35 400		20	12 700		

Basic static moment load of linear guide

Slider	Basic static moment load (N · m)		
	Rolling M _{RO}	Pitching M _{PO}	Yawing M _{YO}
Single	1 460	610	610

MCH10 (Double slider)

Accuracy grade: High grade (H)

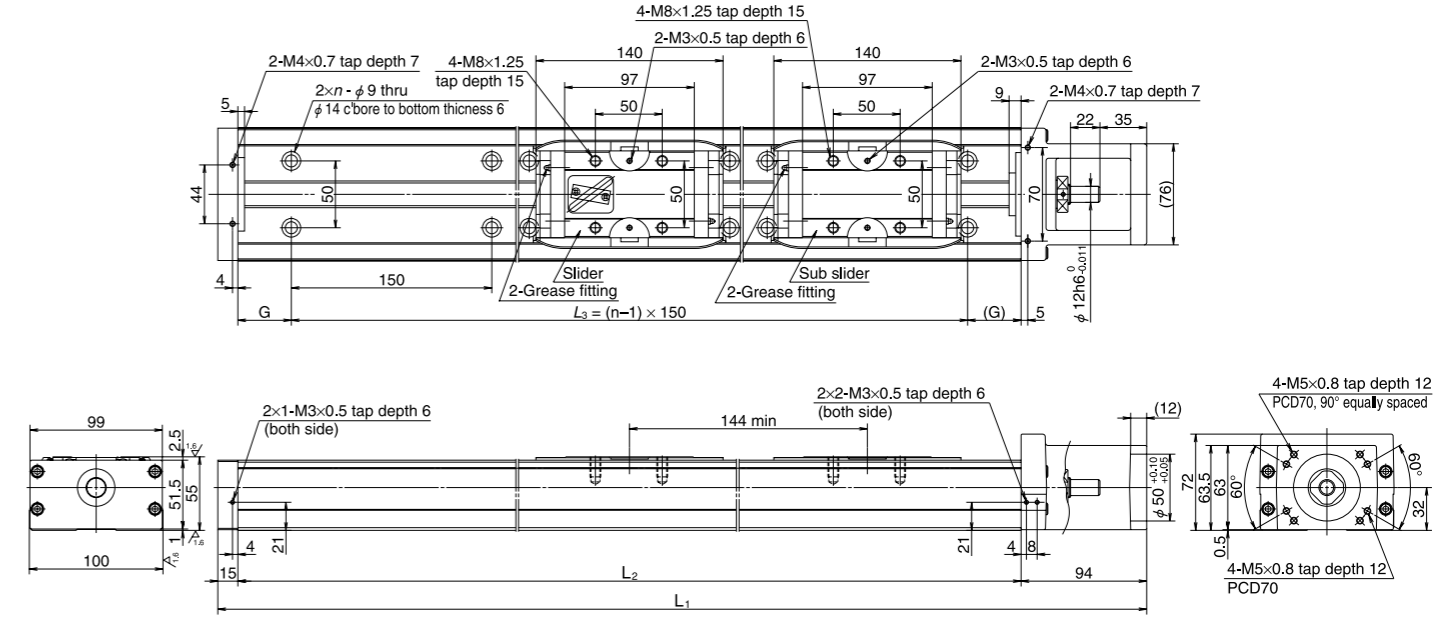

Dimension of MCH10 (Double slider)

Reference No.	Nominal stroke (mm)	Stroke limit (mm) (without K1)	Ball screw lead (mm)	Body length (mm)					Inertia × 10 ⁻⁶ (kg · m ²)	Mass (kg)
				L ₁	L ₂	G	L ₃	n		
MCH10025H10D02	250	282	10	689	580	65	450	4	67.1	15
MCH10025H20D02		(314)	20						82.4	
MCH10035H10D02	350	382	10	789	680	40	600	5	77.3	17
MCH10035H20D02		(414)	20						92.5	
MCH10045H10D02	450	482	10	889	780	15	750	6	87.5	20
MCH10045H20D02		(514)	20						103	
MCH10055H10D02	550	582	10	989	880	65	750	6	97.7	22
MCH10055H20D02		(614)	20						113	
MCH10065H10D02	650	682	10	1 089	980	40	900	7	108	24
MCH10065H20D02		(714)	20						123	
MCH10075H20D02	750	782 (814)	20	1 189	1 080	15	1 050	8	133	26
MCH10085H20D02	850	882 (914)	20	1 289	1 180	65	1 050	8	143	28
MCH10095H20D02	950	982 (1 014)	20	1 389	1 280	40	1 200	9	154	30
MCH10105H20D02	1 050	1 082 (1 114)	20	1 489	1 380	15	1 350	10	164	33

Note: The nominal number in the above table is for high-grade grease specifications. In the case of other specifications, see the following table for the 13th and 14th digits.

Coding for columns 13 and 14

Grease	High-grade	Precision-grade	Monocarrier dynamic torque specification (N · cm)	
Standard	02	(None)	Ball screw lead	10 4.2 – 15.6
LG2	B2	B0	(mm)	20 5.0 – 19.6

- Notes:
- Frictional resistance of NSK K1 is included in dynamic torque in table.
 - Grease is packed into ball screw, linear guide parts and support unit.
 - Consult NSK for life estimates under large moment loads.

Basic load rating

Lead ℓ (mm)	Shaft dia d (mm)	Basic dynamic load rating (N)				Basic static load rating (N)		Support unit load limit (N)
		Ball screw C _a	Linear guides C	Support unit C _a	Rated running distance L _a (km)	Ball screw C _{0a}	Linear guides C ₀	
10	φ20	11 000	44 600	7 600	10	21 100	42 000	3 380
20		7 060	35 400		20	12 700		

Basic static moment load of linear guide

Slider	Basic static moment load (N · m)		
	Rolling M _{RO}	Pitching M _{PO}	Yawing M _{YO}
Double	2 920	3 430	3 430

1-6. 3 MCH Series Accessories

1-6. 3. 1 Sensor Unit

● Proximity switch

Sensor rail is not included in a sensor unit.

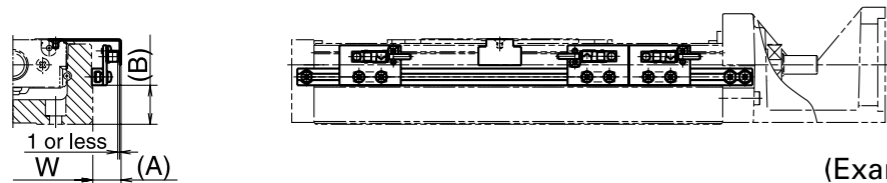

Model No.	Reference No.			A (mm)	B (mm)	Body width W (mm)
MCH06	MC-SRH06-10	MC-SRH06-11	MC-SRH06-12	17	10	60
MCH09	MC-SRH09-10	MC-SRH09-11	MC-SRH09-12	16	21	86
MCH10	MC-SRH10-10	MC-SRH10-11	MC-SRH10-12	16	16	100
Quantity	Proximity switch (normally open contact)	—	3	1	E2S-W13 (OMRON Corp.)	
	Proximity switch (normally close contact)	3	—	2	E2S-W14 (OMRON Corp.)	

Notes: 1. See page 135 for proximity switch specifications. 2. A sensor unit consists of sensors, a sensor dog and sensor mounting parts.

● Photo sensor

Sensor rail is not included in a sensor unit.

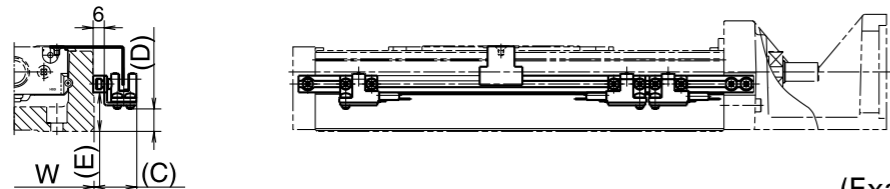

Model No.	Reference No.	C (mm)	D (mm)	E (mm)	Body width W (mm)	Remarks
MCH06	MC-SRH06-13	24	2	11	60	EE-SX674 (OMRON Corp.) 3 sets (EE-1001 connector attachment)
MCH09	MC-SRH09-13	23	12	21	86	
MCH10	MC-SRH10-13	23	29	16	100	

Notes: 1. See page 136 for proximity switch specifications. 2. A sensor unit consists of sensors, a sensor dog and sensor mounting parts.

(1) Sensor rail

Reference number: MC-SRL- * * * *

● * * * * is the same as rail dimension L₂.

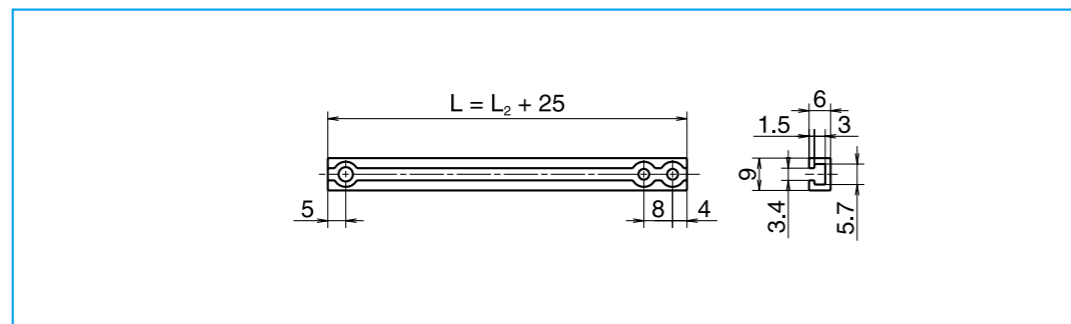

Note: For combinations of sensors and rails, see page 82.

Body of MCH Series and Sensor Rail Combination Table

Table 4

Model No.	Body length L ₂ (mm)	Reference No.	Sensor rail reference No.
MCH06	150	MCH06005H05K02	MC-SRL-0150
		MCH06005H10K02	
		MCH06005H20K02	
	200	MCH06010H05K02	MC-SRL-0200
		MCH06010H10K02	
		MCH06010H20K02	
	300	MCH06020H05K02	MC-SRL-0300
		MCH06020H10K02	
		MCH06020H20K02	
	400	MCH06030H05K02	MC-SRL-0400
		MCH06030H10K02	
		MCH06030H20K02	
MCH06020H05D02			
MCH06020H10D02			
MCH06020H10D02			
500	MCH06040H05K02	MC-SRL-0500	
	MCH06040H10K02		
	MCH06040H20K02		
	MCH06030H05D02		
	MCH06030H10D02		
	MCH06030H10D02		
600	MCH06050H05K02	MC-SRL-0600	
	MCH06050H10K02		
	MCH06050H20K02		
	MCH06040H10D02		
	MCH06040H20D02		
	MCH06040H20D02		
MCL06	150	MCL06005H05K02	MC-SRL-0150
		MCL06005H10K02	
	200	MCL06010H05K02	MC-SRL-0200
		MCL06010H10K02	
	300	MCL06020H05K02	MC-SRL-0300
		MCL06020H10K02	
400	MCL06030H10K02	MC-SRL-0400	
	MCL06030H20K02		
500	MCL06040H10K02	MC-SRL-0500	
	MCL06040H20K02		
600	MCL06050H10K02	MC-SRL-0600	
	MCL06050H20K02		
MCH09	240	MCH09010H05K02	MC-SRL-0240
		MCH09010H10K02	
		MCH09010H20K02	
	340	MCH09020H05K02	MC-SRL-0340
		MCH09020H10K02	
		MCH09020H20K02	
	440	MCH09030H05K02	MC-SRL-0440
		MCH09030H10K02	
		MCH09030H20K02	
	540	MCH09040H05K02	MC-SRL-0540
		MCH09040H10K02	
		MCH09040H20K02	
640	MCH09025H05D02	MC-SRL-0640	
	MCH09025H10D02		
	MCH09025H10D02		
740	MCH09050H05K02	MC-SRL-0740	
	MCH09050H10K02		
	MCH09050H20K02		
	MCH09035H05D02		
	MCH09035H10D02		
	MCH09035H10D02		

Model No.	Body length L ₂ (mm)	Reference No.	Sensor rail reference No.	
MCH09	840	MCH09070H05K02	MC-SRL-0840	
		MCH09070H10K02		
		MCH09070H20K02		
940	940	MCH09080H05K02	MC-SRL-0940	
		MCH09080H10K02		
		MCH09080H20K02		
MCH10	280	MCH10010H10K02	MC-SRL-0280	
		MCH10010H20K02		
		MCH10010H20K02		
	380	380	MCH10020H10K02	MC-SRL-0380
			MCH10020H20K02	
			MCH10020H20K02	
	480	480	MCH10030H10K02	MC-SRL-0480
			MCH10030H20K02	
			MCH10030H20K02	
	580	580	MCH10040H10K02	MC-SRL-0580
			MCH10040H20K02	
			MCH10040H20K02	
	680	680	MCH10050H10K02	MC-SRL-0680
			MCH10050H20K02	
			MCH10050H20K02	
780	780	MCH10035H10D02	MC-SRL-0780	
		MCH10035H20D02		
		MCH10035H20D02		
880	880	MCH10060H10K02	MC-SRL-0880	
		MCH10060H20K02		
		MCH10060H20K02		
980	980	MCH10070H10K02	MC-SRL-0980	
		MCH10070H20K02		
		MCH10070H20K02		
1 080	1 080	MCH10080H10K02	MC-SRL-1080	
		MCH10080H20K02		
		MCH10080H20K02		
1 180	1 180	MCH10090H10K02	MC-SRL-1180	
		MCH10090H20K02		
		MCH10090H20K02		
1 280	1 280	MCH10065H10D02	MC-SRL-1280	
		MCH10065H20D02		
		MCH10065H20D02		
1 380	1 380	MCH10100H10K02	MC-SRL-1380	
		MCH10100H20K02		
		MCH10100H20K02		

1-6. 3. 2 Cover Unit

Cover unit for MCH06 and MCL06

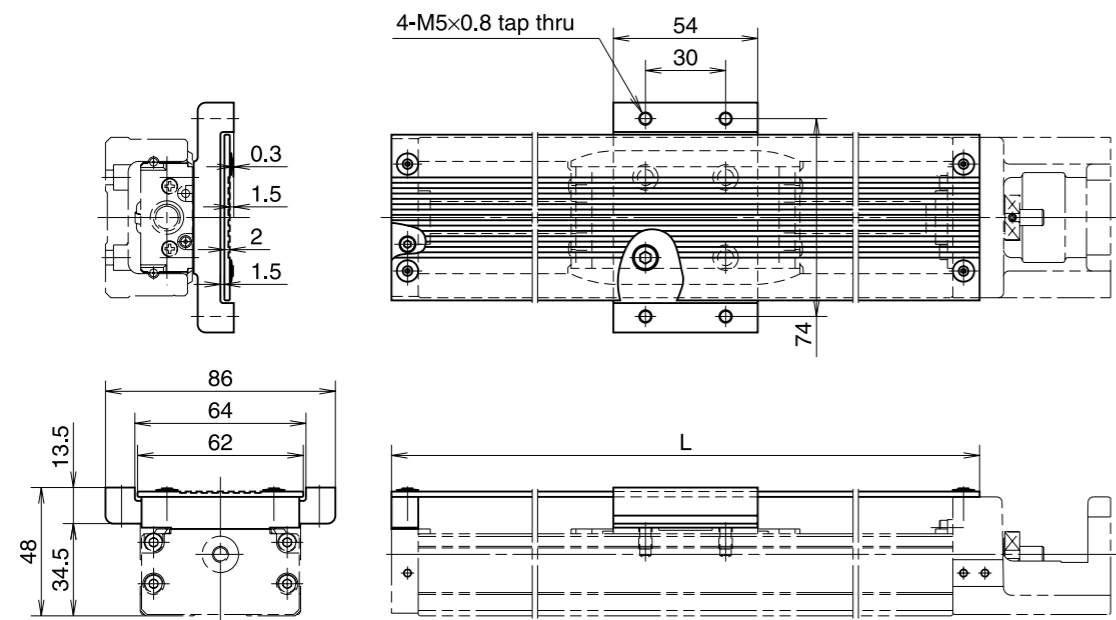

Unit: mm

Single slider		Double slider		Top cover length L
Stroke	Reference No.	Stroke	Reference No.	
50	MC-HV06005-00	-	-	170
100	MC-HV06010-00	-	-	220
200	MC-HV06020-00	100	MC-HV06010D00	320
300	MC-HV06030-00	200	MC-HV06020D00	420
400	MC-HV06040-00	300	MC-HV06030D00	520
500	MC-HV06050-00	400	MC-HV06040D00	620

●Cover unit for double sliders

Two spacers are provided for double slider.

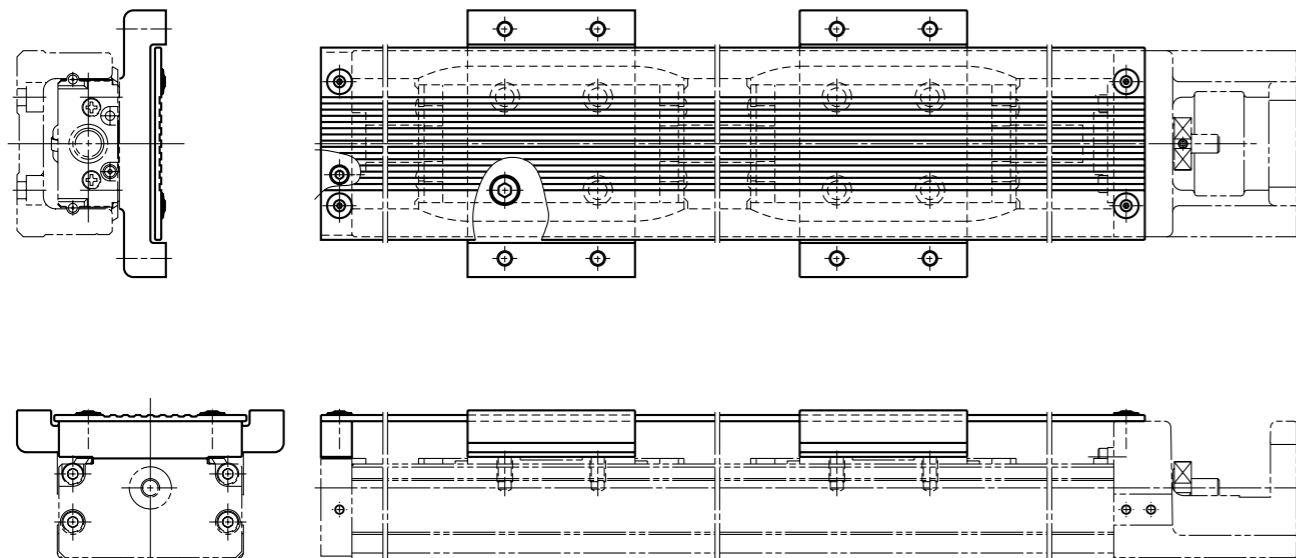

Cover unit for MCH09

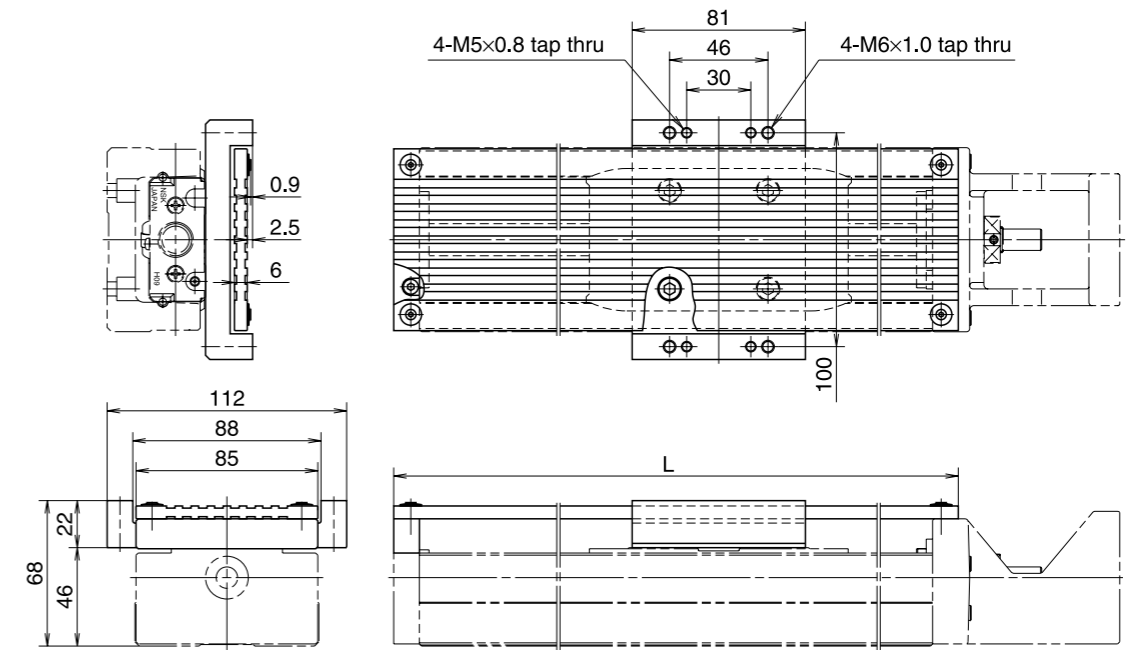

Unit: mm

Single slider		Double slider		Top cover length L
Stroke	Reference No.	Stroke	Reference No.	
100	MC-HV09010-00	-	-	264
200	MC-HV09020-00	-	-	364
300	MC-HV09030-00	150	MC-HV09015D00	464
400	MC-HV09040-00	250	MC-HV09025D00	564
500	MC-HV09050-00	350	MC-HV09035D00	664
600	MC-HV09060-00	450	MC-HV09045D00	764
700	MC-HV09070-00	-	-	864
800	MC-HV09080-00	650	MC-HV09065D00	964

●Cover unit for double sliders

Two spacers are provided for double slider.

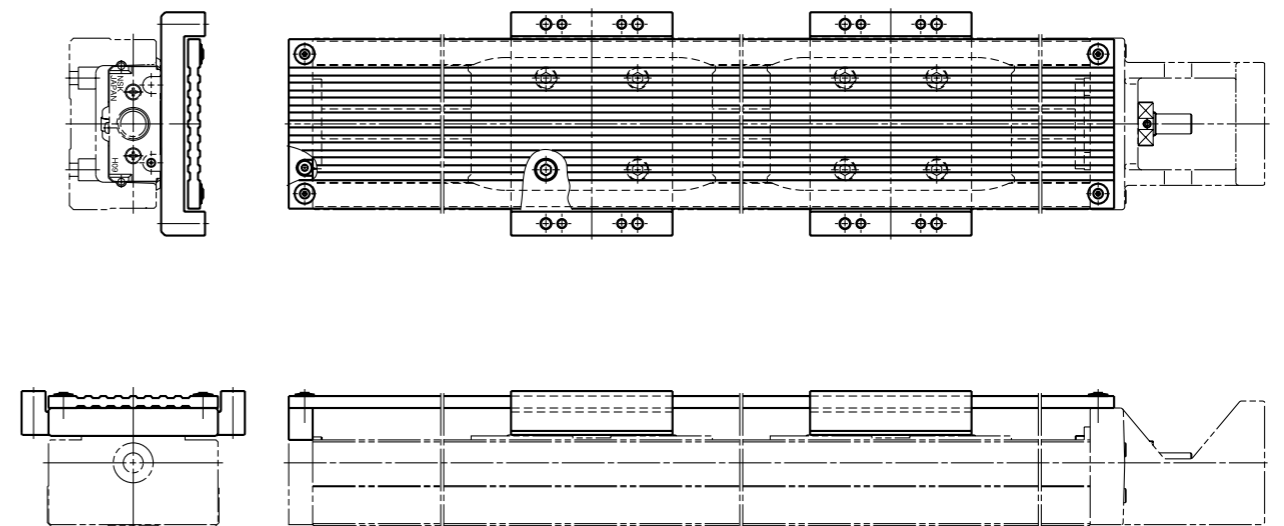

Cover unit for MCH10

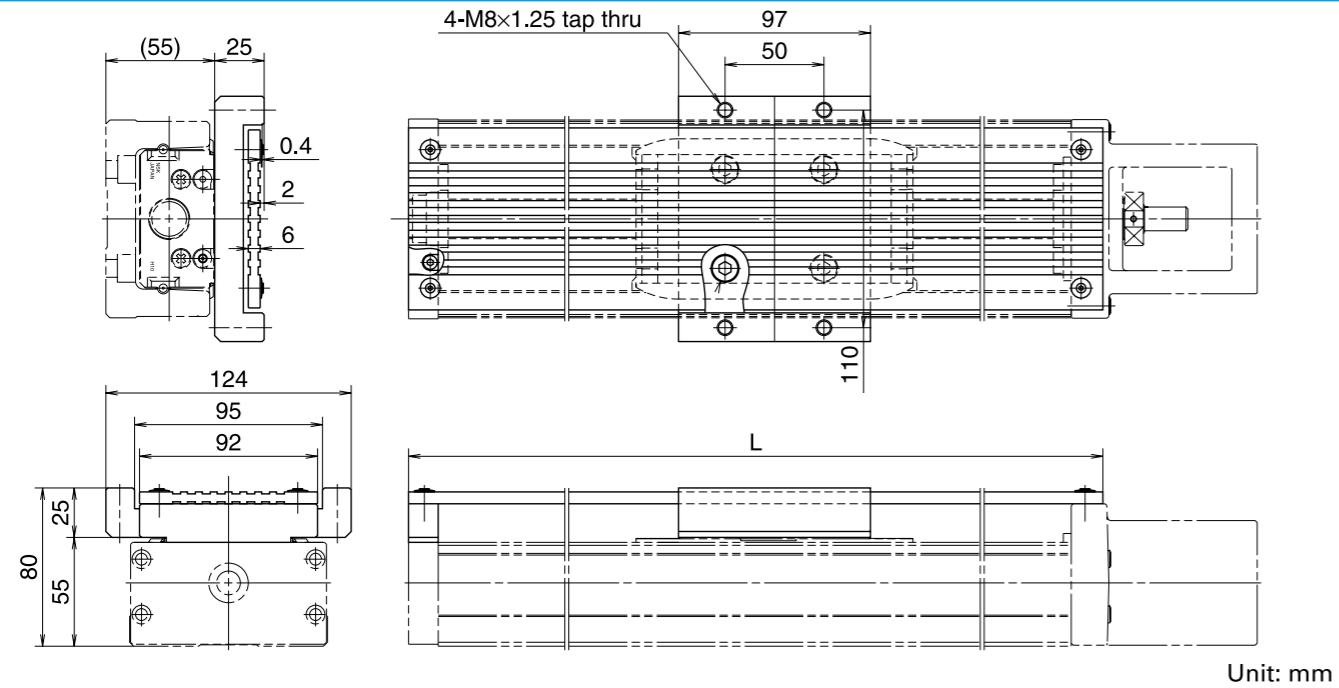

Unit: mm

Single slider		Double slider		Top cover length <i>L</i>
Stroke	Reference No.	Stroke	Reference No.	
100	MC-HV10010-00	-	-	310
200	MC-HV10020-00	-	-	410
300	MC-HV10030-00	-	-	510
400	MC-HV10040-00	250	MC-HV10025D00	610
500	MC-HV10050-00	350	MC-HV10035D00	710
600	MC-HV10060-00	450	MC-HV10045D00	810
700	MC-HV10070-00	550	MC-HV10055D00	910
800	MC-HV10080-00	650	MC-HV10065D00	1 010
900	MC-HV10090-00	750	MC-HV10075D00	1 110
1 000	MC-HV10100-00	850	MC-HV10085D00	1 210
1 100	MC-HV10110-00	950	MC-HV10095D00	1 310
1 200	MC-HV10120-00	1 050	MC-HV10105D00	1 410

●Cover unit for double sliders

Two spacers are provided for double slider.

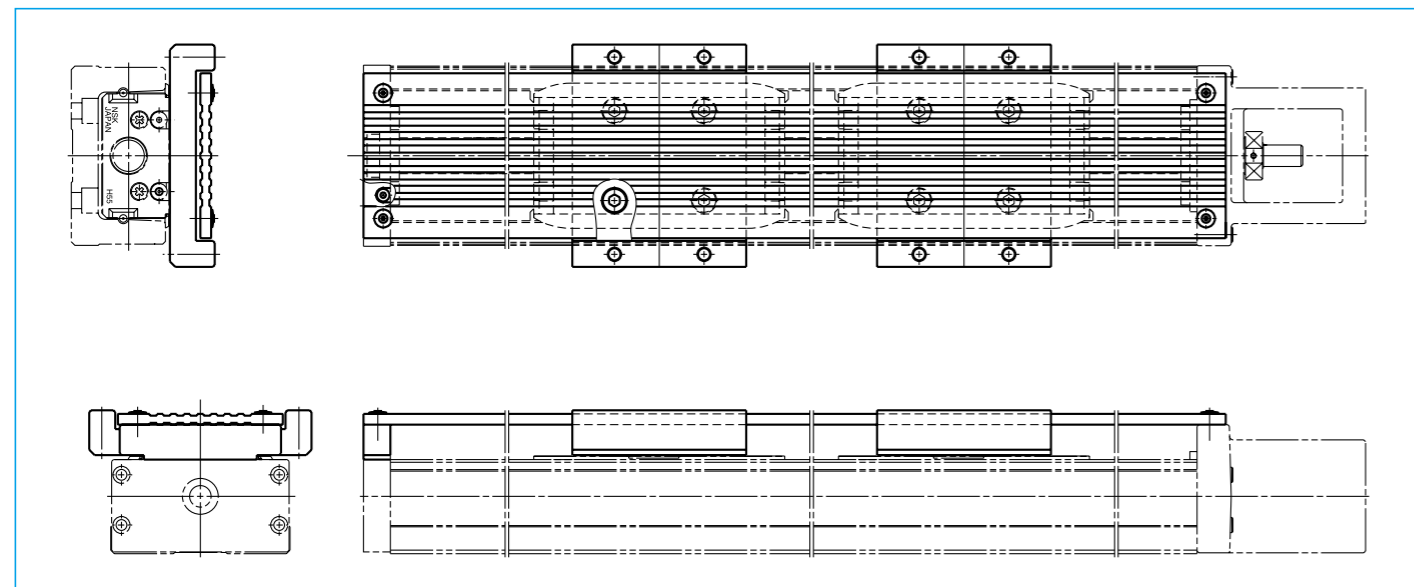

1-6. 3. 3 Intermediate Plate for Motor

- Please ask NSK about motors not listed in compatible motor list.
- In case of parallel motor mount, please consult with NSK.
- Be sure to align centerlines when installing motor.
- Motor models are subject to change at the motor manufacturers. For details, please contact the manufacturer.

Motor Bracket for MCH06 and MCL06

Reference number: MC-BKH06-145-00

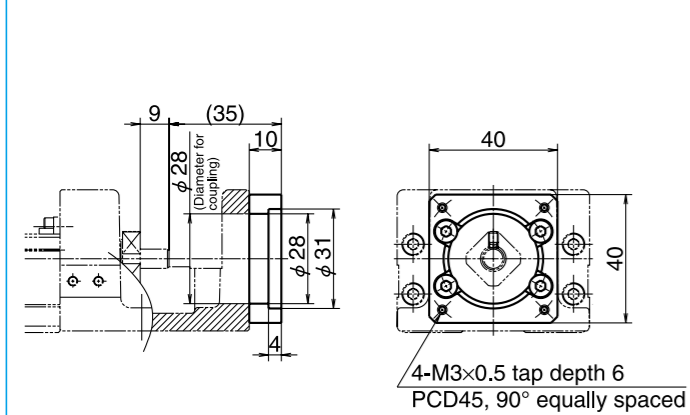

Compatible motor	
Maker	Motor models
Panasonic Co., Ltd.	MSMD5A(50W), MSMD01(100W)

Reference number: MC-BKH06-146-00

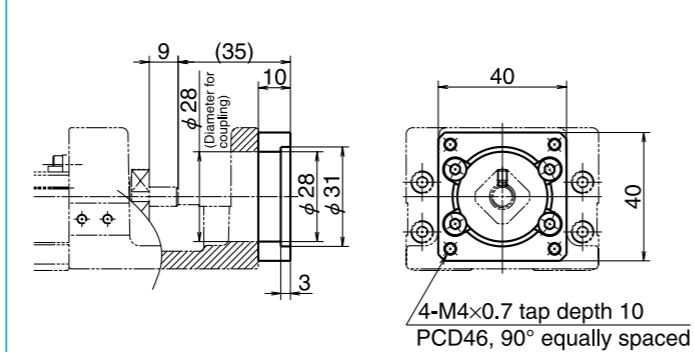

Compatible motor	
Maker	Motor models
YASKAWA Electric Corp.	SGMAH-A3(30W), SGMJV-A5A(50W), SGMVA-A5A(50W), SGMJV-01A(100W), SGMVA-01A(100W)
Mitsubishi Electric Corp.	HF-KP053(50W), HF-MP053(50W), HC-KFS053(50W), HC-MFS053(50W), HF-KP13(100W), HF-MP13(100W), HC-KFS13(100W), HC-MFS13(100W)
OMRON Corp.	R88M-W03(30W), R88M-W05(50W), R88M-W10(100W)
SANYO DENKI Co., Ltd.	P30B04xxx P Series

Reference number: MC-BKH06-231-00

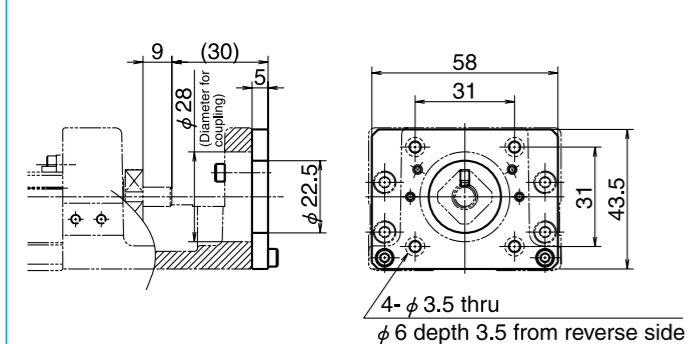

Compatible motor	
Maker	Motor models
ORIENTAL MOTOR Co., Ltd.	AS46, ASC46, UPK54x, PK54x, CSK54x, CFK54x, UMK24x, CSK24x, PK24x
SANYO DENKI Co., Ltd.	PBM423xxx, 103F55xx

Reference number: MC-BKH06-250-00

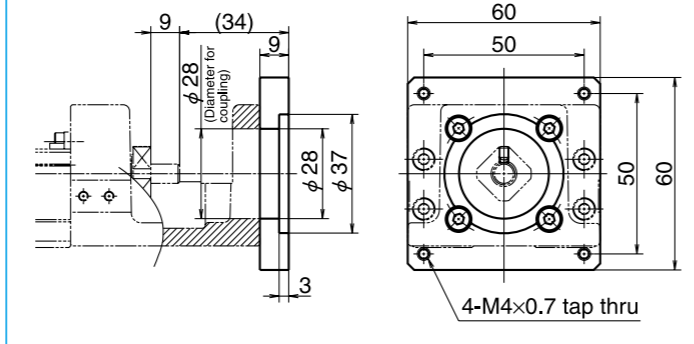

Compatible motor	
Maker	Motor models
ORIENTAL MOTOR Co., Ltd.	AS66, ASC66, UPK56x, UFK56x, PK56x, CSK56x, CFK56x
OMRON Corp.	MUMS02(200W), MUMS04(400W)
SANYO DENKI Co., Ltd.	PBM603xx, PBM604xx, 103F78xx

Diameter of ball screw shaft end to install a pulley for parallel motor mount of MCH06

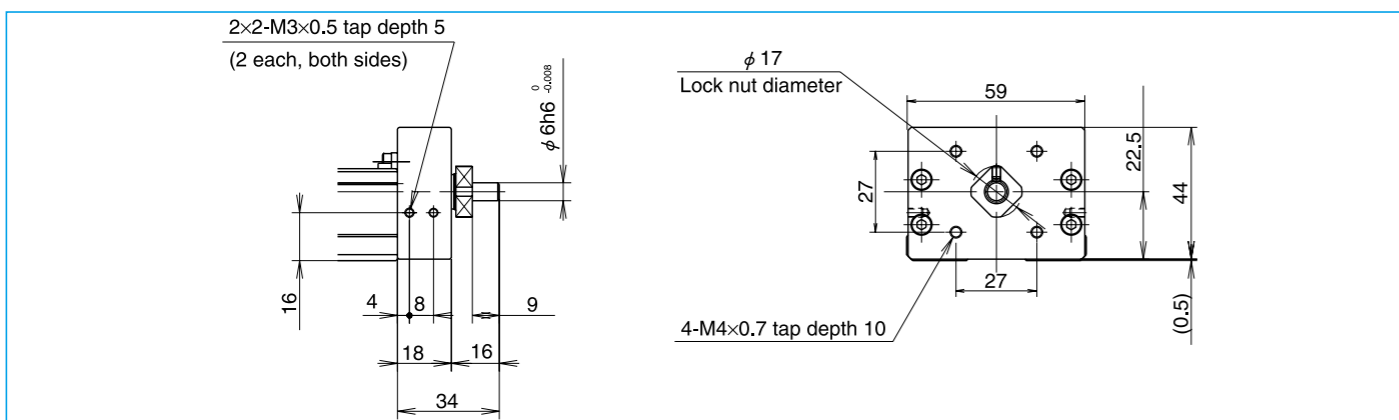

Motor Bracket for MCH09

Reference number: MC-BKH09-145-00
MC-BKH09-146-00

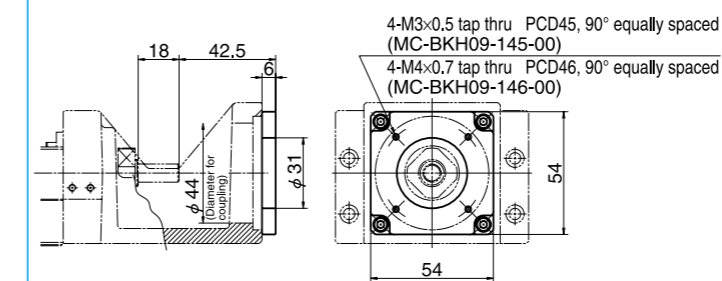

Reference No.	Compatible motor	
	Maker	Motor models
MC-BKH09-145-00	Panasonic Co., Ltd.	MSMD5A(50W), MSMD01(100W)
MC-BKH09-146-00	YASKAWA Electric Corp.	SGMJV-A5A(50W), SGMVA-A5A(50W), SGMJV-01A(100W), SGMVA-01A(100W)
	Mitsubishi Electric Corp.	HF-KP053(50W), HF-MP053(50W), HC-KFS053(50W), HC-MFS053(50W), HF-KP13(100W), HF-MP13(100W), HC-KFS13(100W), HC-MFS13(100W)
MC-BKH09-146-00	OMRON Corp.	R88M-W05(50W), R88M-W10(100W)
	SANYO DENKI Co., Ltd.	P30B04xxx P Series

Reference number: MC-BKH09-231-00

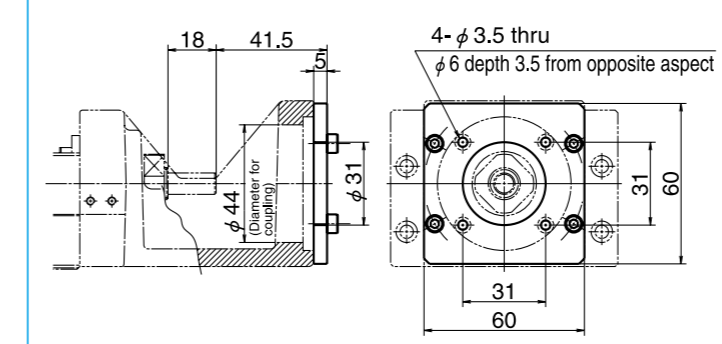

Compatible motor	
Maker	Motor models
SANYO DENKI Co., Ltd.	PBM423xxx, 103F55xx
ORIENTAL MOTOR Co., Ltd.	AS46, ASC46, UPK54x, PK54x, CSK54x, CFK54x, UMK24x, CSK24x, PK24x

Diameter of ball screw shaft end to install a pulley for parallel motor mount of MCH09

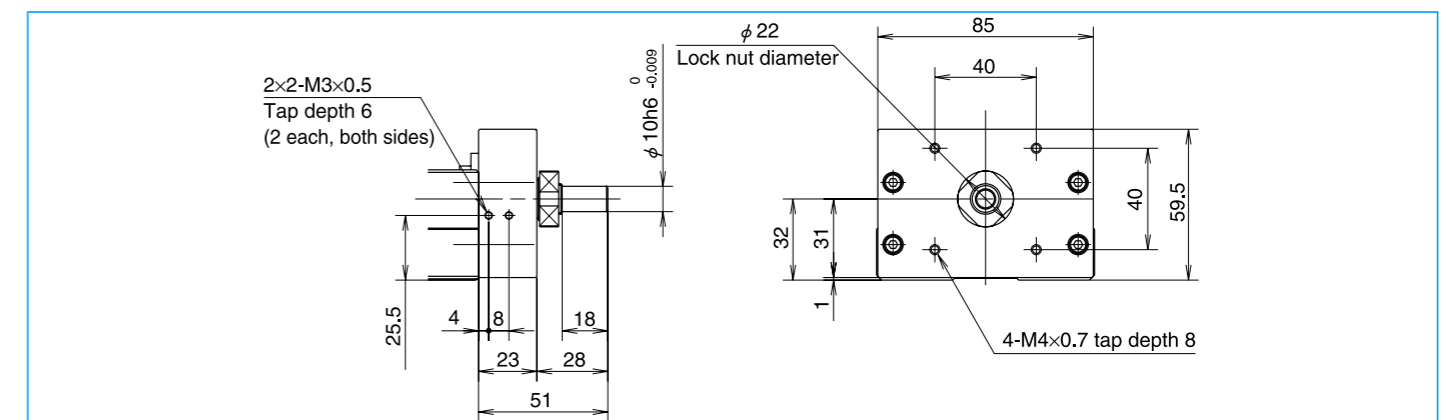

Motor Bracket for MCH10

Reference number: MC-BKH10-170-00
MC-BKH10-170-01

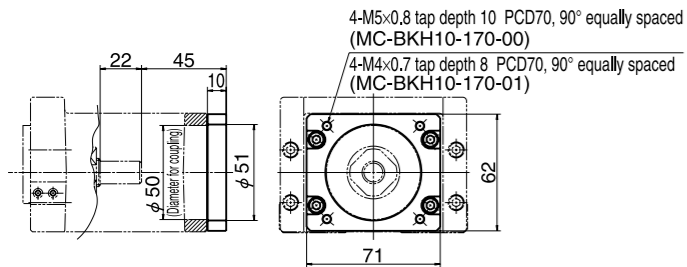

Reference number: MC-BKH10-190-00
MC-BKH10-190-01

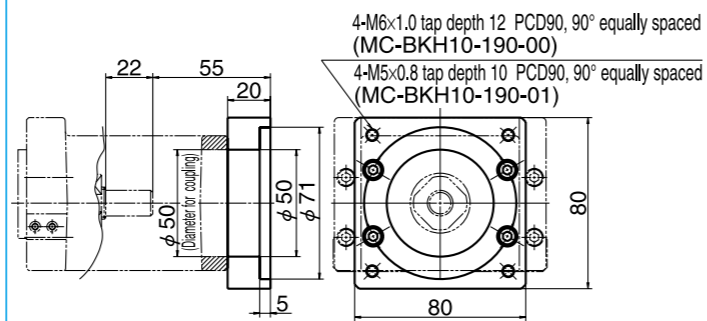

Reference No.	Compatible motor	
	Maker	Motor models
MC-BKH10-170-00	YASKAWA Electric Corp.	SGMJV-02A(200W), SGMJV-02A(200W) SGMJV-04A(400W), SGMJV-04A(400W)
	Mitsubishi Electric Corp.	HF-KP23(200W), HF-MP23(200W), HF-KP43(400W) HF-MP43(400W), HC-KFS23(200W), HC-MFS23(200W) HC-KFS43(400W), HC-MFS43(400W)
	OMRON Corp.	R88M-W20(200W), R88M-W40(400W)
MC-BKH10-170-01	SANYO DENKI Co., Ltd.	P30B06xxx P Series
	Panasonic Co., Ltd.	MSMD02(200W), MSMA02(200W) MSMD04(400W), MSMA04(400W)

Reference No.	Compatible motor	
	Maker	Motor models
MC-BKH10-190-00	Mitsubishi Electric Corp.	HC-KFS73(750W), HC-MFS73(750W) HF-KP73(750W), HF-MP73(750W)
MC-BKH10-190-01	SANYO DENKI Co., Ltd.	P50B07xxx P Series

Reference number: MC-BKH10-250-00

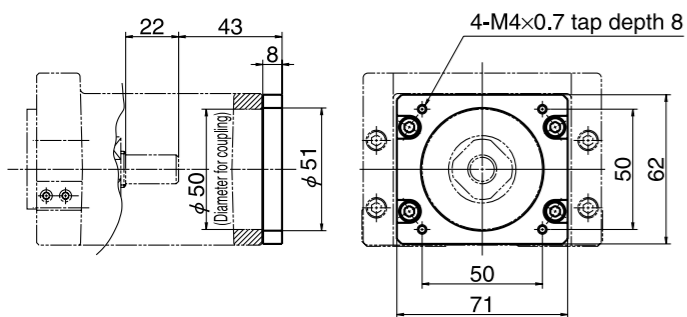

Reference number: MC-BKH10-270-00

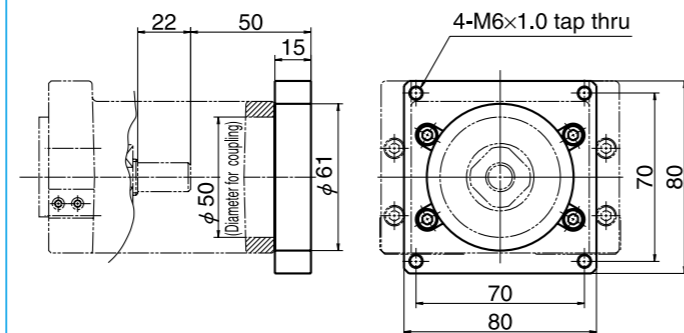

Compatible motor	
Maker	Motor models
SANYO DENKI Co., Ltd.	PBM603xx, PBM604xx, 103F78xx
ORIENTAL MOTOR Co., Ltd.	AS66, ASC66, UPK56x, PK56x, CSK56x, CFK56x UMK56x, UFK56x

Compatible motor	
Maker	Motor models
ORIENTAL MOTOR Co., Ltd.	AS98, ASC98, UPK59x, PK59x, CSK59x, CFK59x UMK59x, UFK59x

Diameter of ball screw shaft end to install a pulley for parallel motor mount of MCH10

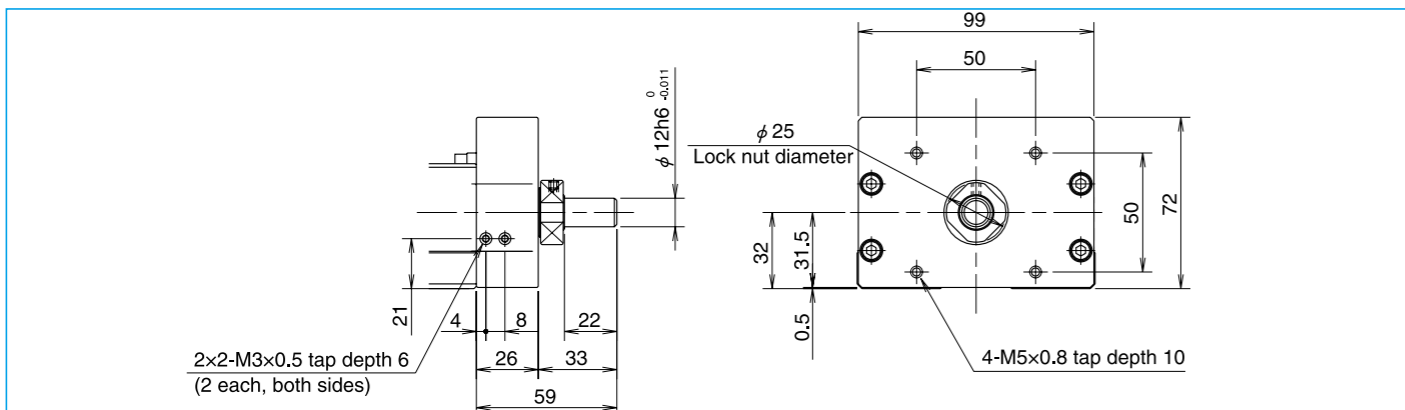

Motor Availability Table of Intermediate Plate for MCH Series

Table 5

Model No.	Reference No. code	Motor bracket reference No.	Motor manufacturer	Stepping motor model No.	Wattage of AC servo motor									
					30	50	100	200	400	750				
MCH06 MCL06	1	MC-BKH06-145-00	Panasonic Co., Ltd.			MSMD5A	MSMD01							
	2	MC-BKH06-146-00	YASKAWA Electric Corp.	SGMAH-A3	SGMJV-A5A	SGMAV-A5A	SGMJV-01A	SGMAV-01A						
			Mitsubishi Electric Corp.		HF-KP053	HF-MP053	HF-KP13	HF-MP13	HC-KFS13	HC-MFS13				
			OMRON Corp.		R88M-W03	R88M-W05	R88M-W10							
	3	MC-BKH06-231-00	SANYO DENKI Co., Ltd.	P30B04xxx (P Series)	PBM423xxx	103F55xx								
			ORIENTAL MOTOR Co., Ltd.		AS46, ASC46	UPK54x, PK54x	CSK54x, CFK54x	UMK24x, CSK24x	PK24x					
	4	MC-BKH06-250-00	SANYO DENKI Co., Ltd.		PBM603xx	PBM604xx	103F78xx							
			ORIENTAL MOTOR Co., Ltd.		AS66, ASC66	UPK56x, UFK56x	PK56x, CSK56x	CFK56x						
			OMRON Corp.							MUMS02	MUMS04			
	1	MC-BKH09-145-00	Panasonic Co., Ltd.			MSMD5A	MSMD01							
	2	MC-BKH09-146-00	YASKAWA Electric Corp.			SGMJV-A5A	SGMAV-A5A	SGMJV-01A	SGMAV-01A					
			Mitsubishi Electric Corp.			HF-KP053	HF-MP053	HF-KP13	HF-MP13	HC-KFS13	HC-MFS13			
OMRON Corp.					R88M-W05	R88M-W10								
3	MC-BKH09-170-00	YASKAWA Electric Corp.					SGMJV-02A	SGMAV-02A	SGMJV-04A	SGMAV-04A				
		Mitsubishi Electric Corp.			HF-KP23	HF-MP23	HF-KP43	HF-MP43	HC-KFS23	HC-MFS23	HC-KFS43	HC-MFS43		
		OMRON Corp.			R88M-W20	R88M-W40								
4	MC-BKH09-170-01	Panasonic Co., Ltd.					MSMD02	MSMA02	MSMD04	MSMA04				
5	MC-BKH09-231-00	SANYO DENKI Co., Ltd.			PBM423xxx	103F55xx								
		ORIENTAL MOTOR Co., Ltd.			AS46, ASC46	UPK54x, PK54x	CSK54x, CFK54x	UMK24x, CSK24x	PK24x					
6	MC-BKH09-250-00	SANYO DENKI Co., Ltd.			PBM603xx	PBM604xx	103F78xx							
		ORIENTAL MOTOR Co., Ltd.			AS66, ASC66	UPK56x, UFK56x	PK56x, CSK56x	CFK56x						
1	MC-BKH10-170-00	YASKAWA Electric Corp.					SGMJV-02A	SGMAV-02A	SGMJV-04A	SGMAV-04A				
		Mitsubishi Electric Corp.			HF-KP23	HF-MP23	HF-KP43	HF-MP43	HC-KFS23	HC-MFS23	HC-KFS43	HC-MFS43		
		OMRON Corp.			R88M-W20	R88M-W40								
2	MC-BKH10-170-01	Panasonic Co., Ltd.					MSMD02	MSMA02	MSMD04	MSMA04				
3	MC-BKH10-190-00	Mitsubishi Electric Corp.									HC-KFS73	HC-MFS73	HF-KP73	HF-MP73
		SANYO DENKI Co., Ltd.			P50B07xxx (P Series)									
		SANYO DENKI Co., Ltd.			PBM603xx	PBM604xx	103F78xx							
5	MC-BKH10-250-00	ORIENTAL MOTOR Co., Ltd.			AS66, ASC66	UPK56x, PK56x	CSK56x, CFK56x	UMK56x, UFK56x						
		ORIENTAL MOTOR Co., Ltd.			AS98, ASC98	UPK59x, PK59x	CSK59x, CFK59x	UMK59x, UFK59x						
6	MC-BKH10-270-00	ORIENTAL MOTOR Co., Ltd.												

2 Toughcarrier™

2-1. Features	93
2-2. Classification and Series	93
2-3. Accessories	95
2-4. Selection of Toughcarrier	96
2-4.1 Selection Procedures	96
2-4.2 Stroke and Lead	97
2-4.3 Reference Number Coding and Accuracy Grade	98
2-4.4 Maximum Speed	99
2-4.5 Rigidity	101
2-4.6 Basic Load Rating	102
2-4.7 Estimation of Life Expectancy	103
2-4.8 Example of Life Estimation	105
2-5. TCH Series Dimension Table of Standard Products	109
2-5.1 TCH06 Series	109
2-5.2 TCH09 Series	111
2-5.3 TCH10 Series	113
2-6. Accessories	115
2-6.1 Sensor Unit	115
2-6.2 Cover Unit	116
2-6.3 Motor Bracket	119
2-7. Motor Bracket Compatibility Table	128
2-8. Sensor Rail and Top Cover Unit Combination Table	129
2-9. Toughcarrier High-Thrust Series	132

2 Toughcarrier™

2-1 Features

Greatly improved load capacity due to switching of rolling elements to rollers.
Mounting dimensions are compatible with those of the MCH Series, allowing substitution.

● **Light weight and compact design**

Taking into account part composition and rigidity, the cross sections of the rail and slider are the same as MCH series.

● **Superb rust-preventive ability**

Low-temperature chrome plating comes standard.

● **All-in-one structure**

- 1) The all-in-one structure integrates a ball screw, a linear guide and a support unit into a single structure to significantly reduce design time.
- 2) The bottom and one side of the rail are datum surfaces to facilitate highly accurate installation. Models with pin holes are also available as standard.
- 3) Immediate operation after installation and run-in is possible due to pre-packed grease.
- 4) A wide selection of ball screw leads are available.

● **Long-term maintenance-free operation**

Use of NSK K1 lubrication unit and grease maintains smooth lubricating performance for long periods.

● **Updated rolling elements**

Rollers are installed as rolling elements for the first time anywhere.

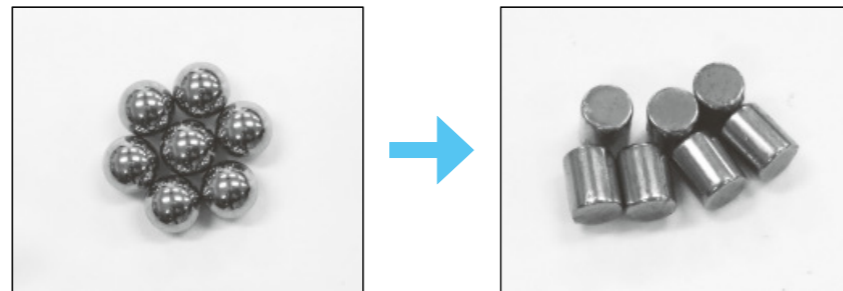

2-2 Classification and Series

Structure

Rolling elements: Balls

MCH Series

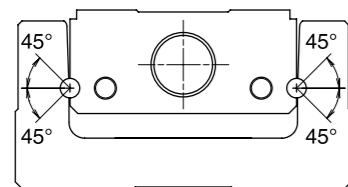

Rolling elements: Rollers

TCH Series

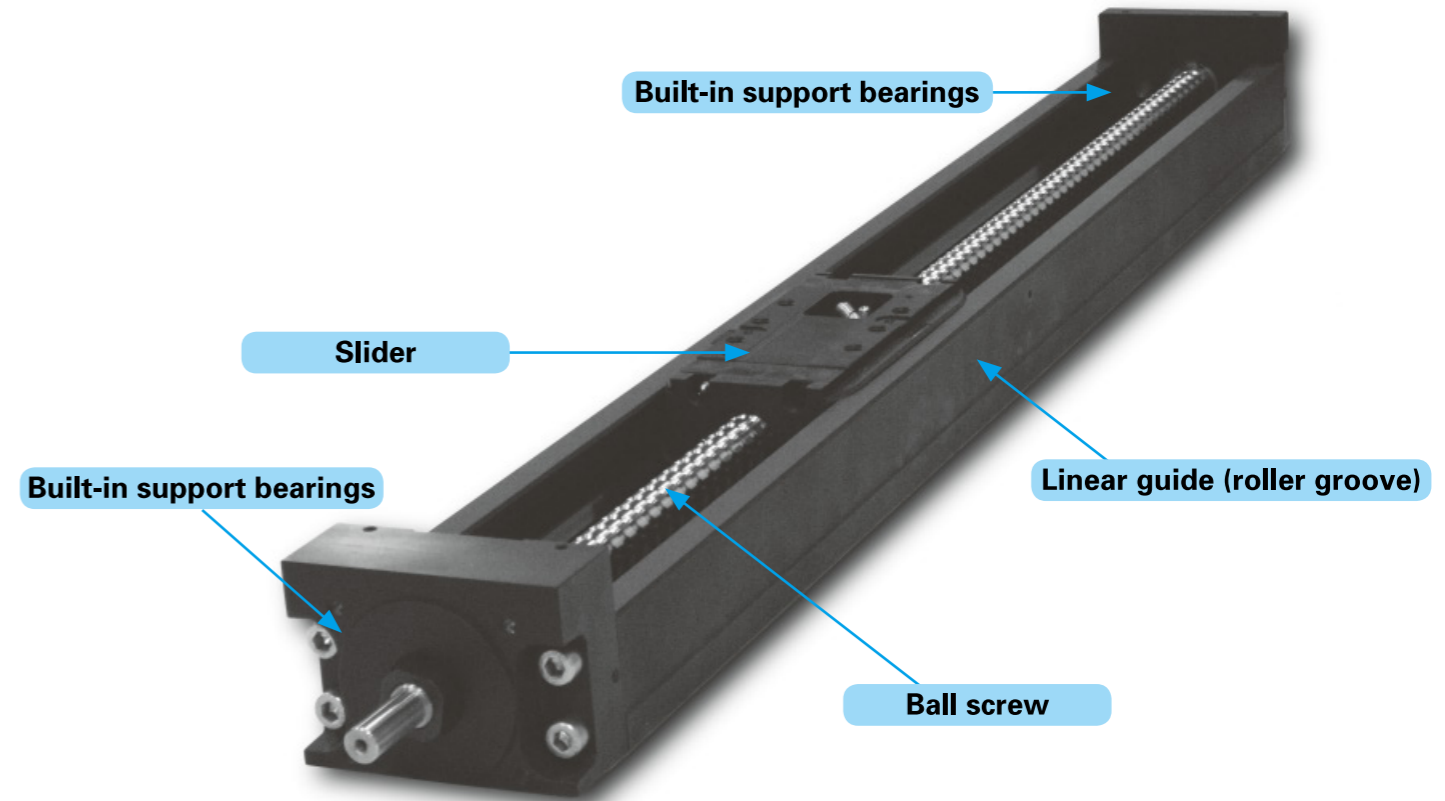
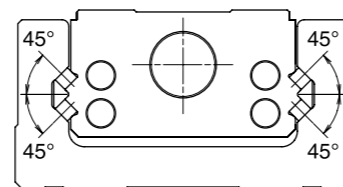

● **High rigidity, long life (N)**

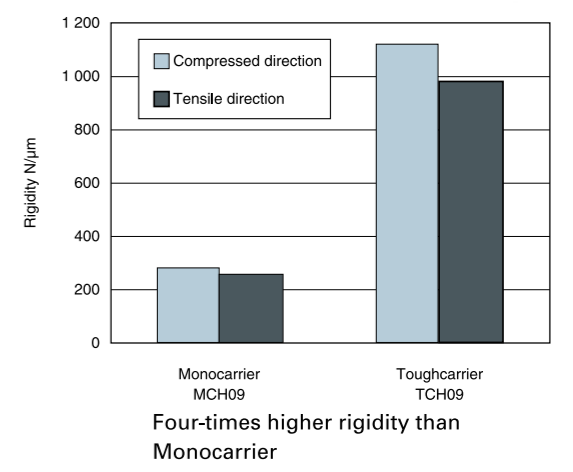
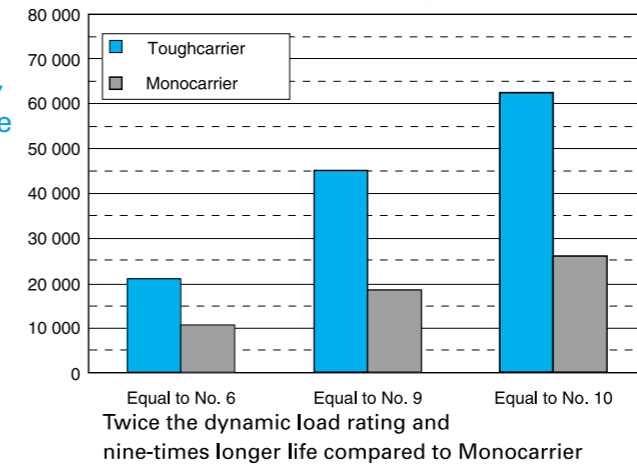

Cross-sections of TCH Series

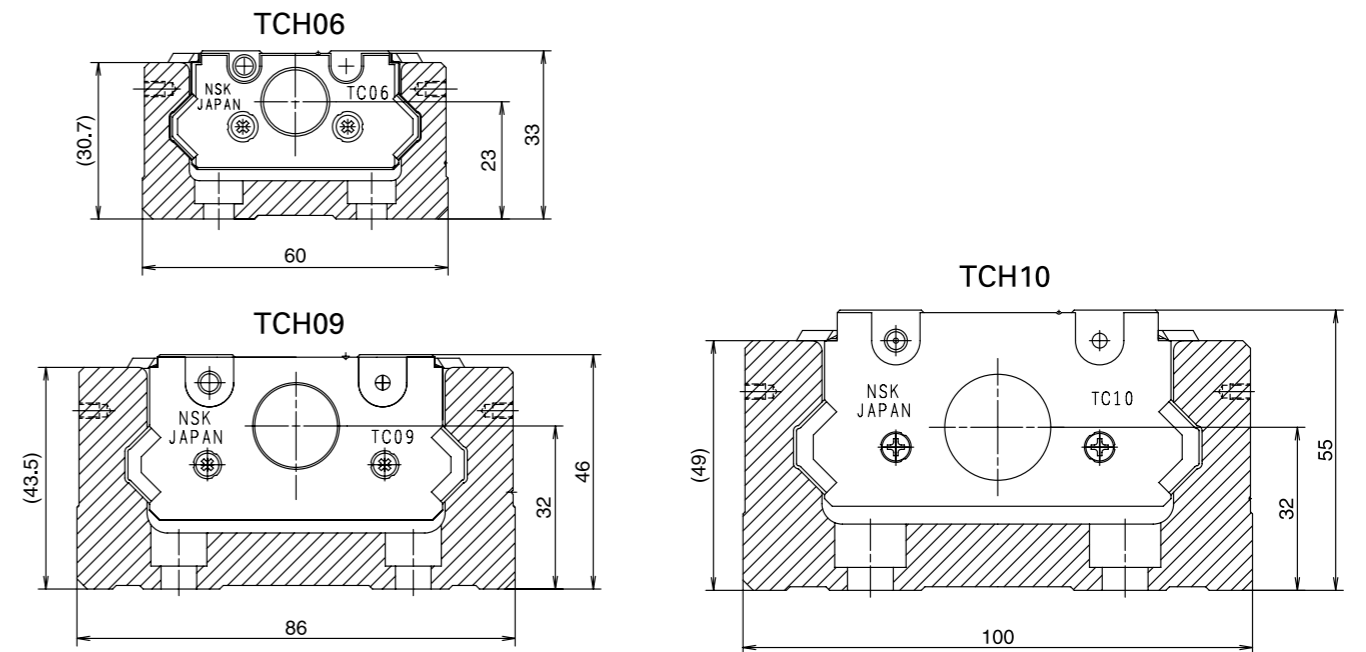

2-3 Accessories

Accessories for Toughcarrier

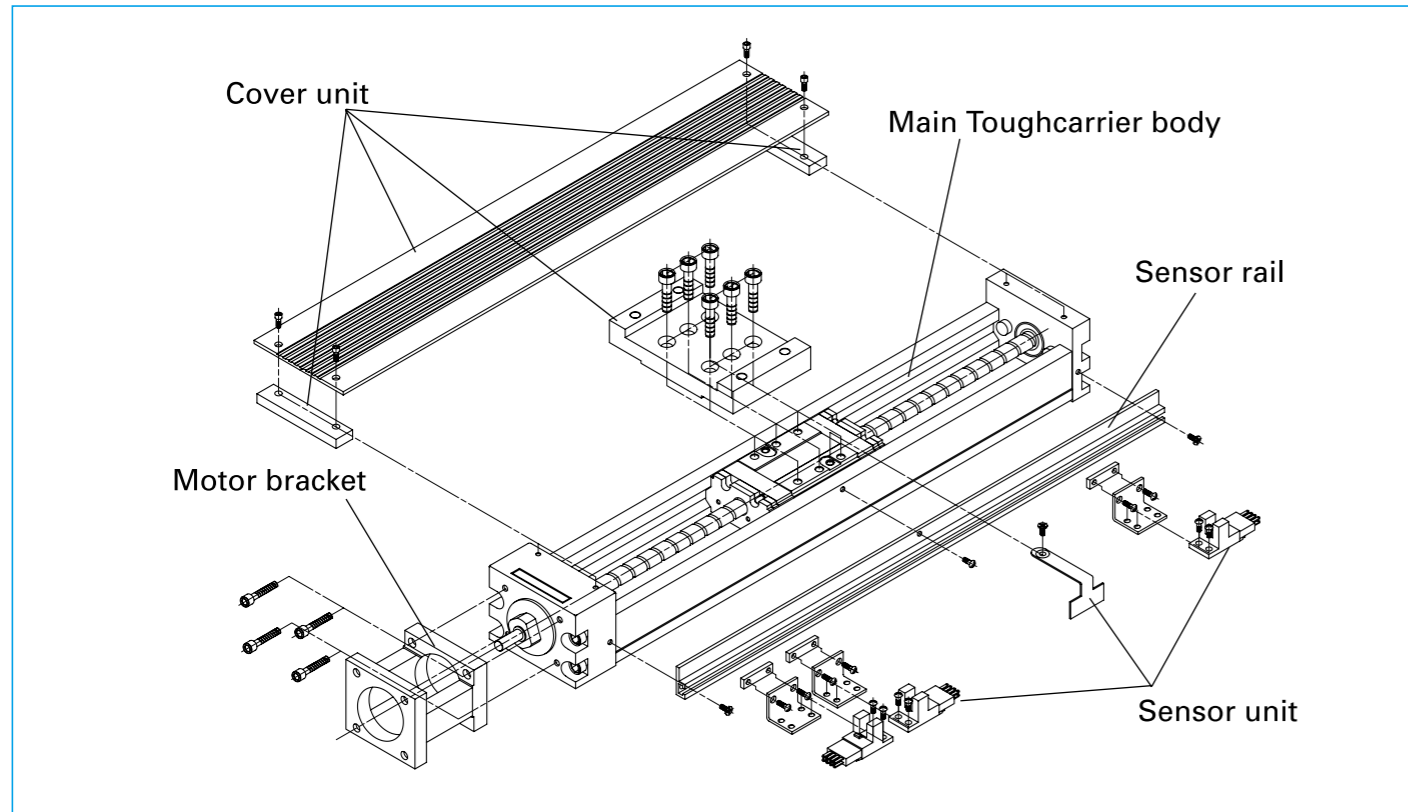

Assembly Example of accessories

Sensor unit, cover unit, motor bracket and sensor rail are available as options for Toughcarrier. Contact NSK for other specifications other than those of NSK standard accessories.

1. Sensor unit:
 - Photo sensor...Use of both OMRON EE-SX674 and EE-1001
 - Proximity switch...Use of OMRON E2S-W13, E2S-W14
 Available in a unit including sensor fitting clamps.
2. Sensor rail : This rail holds the sensor. Please order the appropriate rail according to the stroke.
3. Cover unit : This unit consists of a top cover and spacer plate.
4. Motor bracket: Brackets are available for a variety of models from different motor manufacturers. Please consult NSK when the mounting dimensions differ from your order.

2-4 Selection of Toughcarrier

2-4. 1 Selection Procedure for Toughcarrier

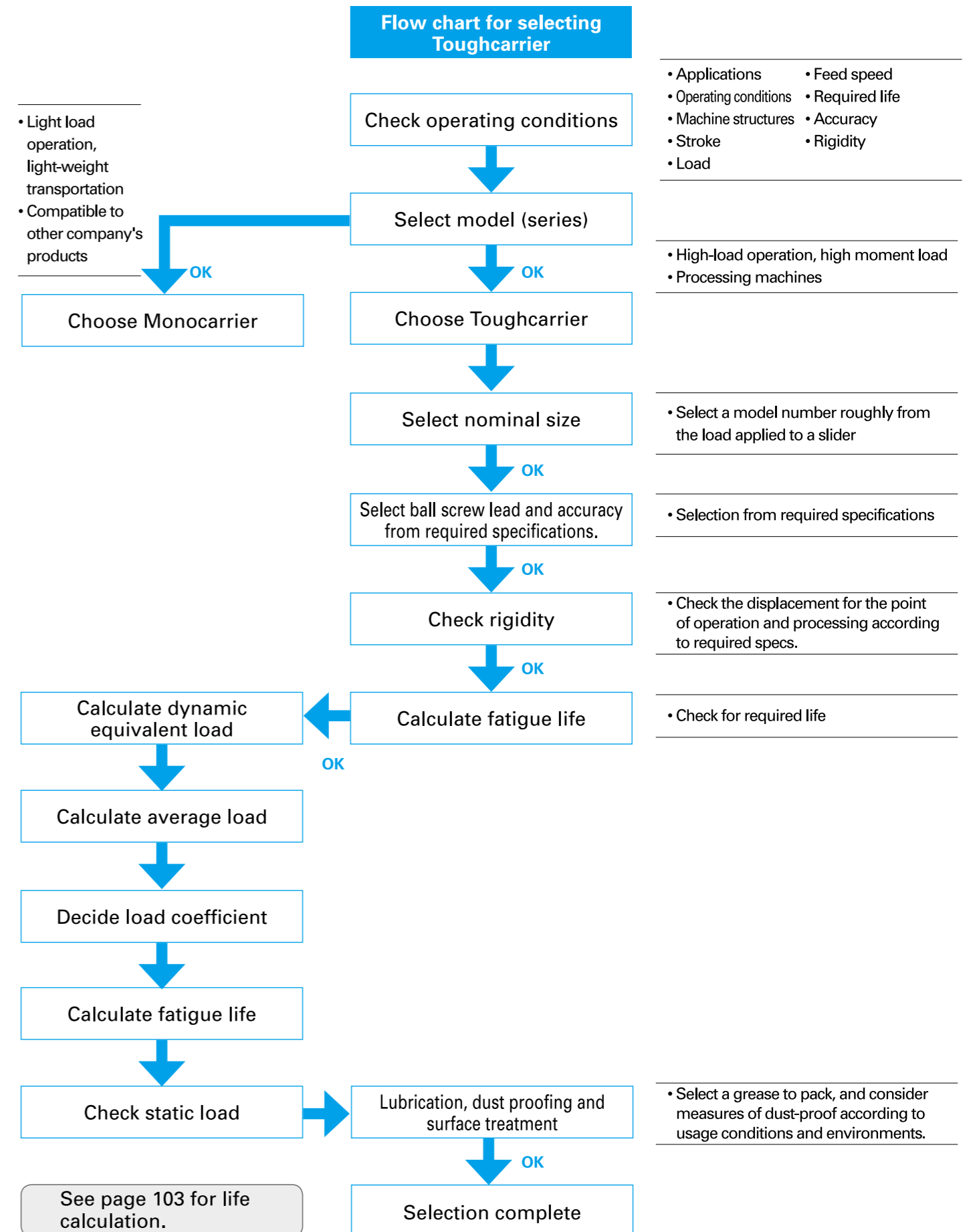

2-4. 2 Stroke and Lead

◆ Combinations of rail length and lead

● TCH06

Slider type Lead (mm) Rail length (mm)	Standard slider						Short slider					
	Single slider			Double slider			Single slider			Double slider		
	5	10	20	5	10	20	5	10	20	5	10	20
150	✓	✓	✓				✓	✓				
200	✓	✓	✓				✓	✓				
300	✓	✓	✓	✓	✓		✓	✓		✓	✓	
400	✓	✓	✓	✓	✓		✓	✓		✓	✓	
500	✓	✓	✓	✓	✓		✓	✓		✓	✓	
600	✓	✓	✓		✓	✓	✓	✓			✓	

*20 mm lead for short sliders not available.

● TCH09

Slider type Lead (mm) Rail length (mm)	Standard slider						Short slider					
	Single slider			Double slider			Single slider			Double slider		
	5	10	20	5	10	20	5	10	20	5	10	20
240	✓	✓	✓				✓	✓	✓			
340	✓	✓	✓				✓	✓	✓			
440	✓	✓	✓	✓	✓		✓	✓	✓	✓	✓	
540	✓	✓	✓	✓	✓		✓	✓	✓	✓	✓	
640	✓	✓	✓	✓	✓		✓	✓	✓	✓	✓	
740	✓	✓	✓		✓	✓	✓	✓	✓		✓	✓
840	✓	✓	✓				✓	✓	✓			
940	✓	✓	✓		✓	✓	✓	✓	✓		✓	✓

● TCH10

Slider type Lead (mm) Rail length (mm)	Standard slider				Short slider			
	Single slider		Double slider		Single slider		Double slider	
	10	20	10	20	10	20	10	20
280	✓	✓			✓	✓		
380	✓	✓			✓	✓		
480	✓	✓			✓	✓		
580	✓	✓	✓	✓	✓	✓	✓	✓
680	✓	✓	✓	✓	✓	✓	✓	✓
780	✓	✓	✓	✓	✓	✓	✓	✓
880	✓	✓	✓	✓	✓	✓	✓	✓
980	✓	✓	✓	✓	✓	✓	✓	✓
1 080	✓	✓		✓	✓	✓		✓
1 180	✓	✓		✓	✓	✓		✓
1 280	✓	✓		✓	✓	✓		✓
1 380	✓	✓		✓	✓	✓		✓

◆ Availability

Model No.	Lead (mm)	Slider	Rail length (mm)
TCH06	5, 10, 20	Single	600
		Double	
TCH09	5, 10, 20	Single	940
		Double	
TCH10	10, 20	Single	1 380
		Double	

2-4. 3 Reference Number Coding and Accuracy Grade

● Reference number coding for TCH Series

Body
Reference number: **TC H 06 030 H 10 K 0 0**

Toughcarrier
Model: TCH Series
(with accessories: TCS)
Nominal size (rail width, 10 mm units)
Stroke (10 mm units)
Accuracy grade: H, High grade; P, Precision grade

NSK control number (0: without pin holes)
(1: with pin holes)
Grease (0: YS2, standard)
Slider specification*
Ball screw lead (mm)

* K: Single slider
D: Double slider
A: Single short slider
B: Double short slider

Special specifications
Reference number: **TC H 06 030 H 10 K - [] XXB**

3: Toughcarrier for special specs
5: Toughcarrier high-thrust series*
Design serial number

* For the specifications of the High-Thrust Series, see page 132.

● Reference number for accessories

1. Sensor unit
Reference number: **TC - SRH XX - 00**
Toughcarrier
Sensor unit
Nominal size: 06, 09 and 10
Control no.: see page 115

2. Sensor rail
Reference number: **TC - SRL X - XXXX**
Toughcarrier
Sensor rail
Nominal size: 06 is 6, 09 is 9, and 10 is 1.
Body rail length

3. Cover unit
Reference number: **TC - HV XX XXX - K 00**
Toughcarrier
Cover unit
Nominal size: 06, 09 and 10
Stroke (nominal)
Slider specs: refer to the body reference no.
Control no.: See pages 116 to 118

4. Motor bracket
Reference number: **TC - BKH XX - XXX - 00**
Toughcarrier
Motor bracket
Nominal size: 06, 09 and 10
Dimension for motor mounting
Control no.

◆ Accuracy grade

Stroke (mm)	High grade (H grade)			Precision grade (P grade)			
	Repeatability	Running parallelism (vertical)	Backlash	Repeatability	Positioning accuracy	Running parallelism (vertical)	Backlash
~ 200	±10	14	20 or less	±3	20	8	3 or less
~ 400		16			25	10	
~ 600		20			30	12	
~ 700		23			35	15	
~ 1 000		30			40	20	

High and precision grades are available for accuracy grade. Consult NSK for your requirements.

2-4. 4 Maximum Speed

● Maximum speed (standard slider)

Maximum speed of the Toughcarrier is determined by the critical speed of the ball screw shaft and the $d \cdot n$ value.

Do not exceed the maximum speed in the table below.

	Stroke (nominal)	Ball screw lead (mm)	Body rail length L_2 (mm)	Maximum speed (mm/s)	
TCH06 Single slider	50	5	150	250	
	100		200		
	200		300		
	300		400		
	400		500		
	500	600	10	500	
	100	150			
	200	200			
	300	300			
	400	400			
	500	500	20	1 000	
	100	150			
	200	200			
	300	300			
	400	400			
TCH06 Double slider	130	5	300	250	
	230		400		
	330	10	500	500	
	430		600		
	530		700		
TCH09 Single slider	100	5	240	250	
	200		340		
	300		440		
	400		540		
	500		640		
	600	740	10	500	
	700	840			
	800	940			
	100	240			
	200	340			
	300	440	20	1 000	
	400	540			
	500	640			
	600	740			
	700	840			
	TCH09 Double slider	100	5	240	210
		200		340	
		300		440	
		400		540	
		500		640	
600		740	10	500	
700		840			
800		940			
100		240			
200		340			
300		440	20	1 000	
400		540			
500		640			
600		740			
700		840			
800	940	820			

Note: If you need to operate the Toughcarrier near the critical speed or in excess of the maximum speed in the table, please consult NSK.

● Maximum speed (short slider)

Maximum speed of the Toughcarrier is determined by the critical speed of the ball screw shaft and the $d \cdot n$ value.

Do not exceed the maximum speed in the table below.

	Stroke (nominal)	Ball screw lead (mm)	Body rail length L_2 (mm)	Maximum speed (mm/s)	
TCH06 Single slider	70	5	150	250	
	120		200		
	220		300		
	320		400		
	420		500		
	520	600	10	500	
	70	150			
	120	200			
	220	300			
	320	400			
	TCH06 Double slider	170	5	300	250
		270		400	
		370		500	
		470		600	
		570		700	
670		800	10	500	
770		900			
870		1 000			
970		1 100			
1 070		1 200			
TCH09 Single slider		140	5	240	250
		240		340	
		340		440	
		440		540	
		540		640	
	640	740	10	500	
	740	840			
	840	940			
	940	1 040			
	1 040	1 140			
	1 140	1 240	20	1 000	
	1 240	1 340			
	1 340	1 440			
	1 440	1 540			
	1 540	1 640			
	TCH09 Double slider	240	5	340	240
		340		440	
		440		540	
		540		640	
		640		740	
740		840	10	480	
840		940			
940		1 040			
1 040		1 140			
1 140		1 240			
1 240		1 340	20	960	
1 340		1 440			
1 440		1 540			
1 540		1 640			
1 640		1 740			
TCH10 Single slider	160	5	280	500	
	260		380		
	360		480		
	460		580		
	560		680		
	660	780	10	490	
	760	880			
	860	980			
	960	1 080			
	1 060	1 180			
	1 160	1 280	20	980	
	1 260	1 380			
	1 360	1 480			
	1 460	1 580			
	1 560	1 680			
TCH10 Double slider	260	5	380	240	
	360		480		
	460		580		
	560		680		
	660		780		
	760	880	10	380	
	860	980			
	960	1 080			
	1 060	1 180			
	1 160	1 280			
	1 260	1 380	20	760	
	1 360	1 480			
	1 460	1 580			
	1 560	1 680			
	1 660	1 780			

Note: If you need to operate the Toughcarrier near the critical speed or in excess of the maximum speed in the table, please consult NSK.

2-4. 5 Rigidity

Rigidity of rail

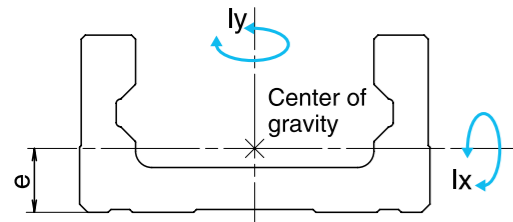

Model no.	Geometrical moment of inertia $\times 10^4$ (mm ⁴)		Center of gravity (mm)	Mass (kg/100mm)
	I _x	I _y	e	w
TCH06	6.47	36.2	10.6	0.6
TCH09	28.4	162	15.7	1.32
TCH10	46	283	17.2	1.73

◆ Rigidity in radial direction

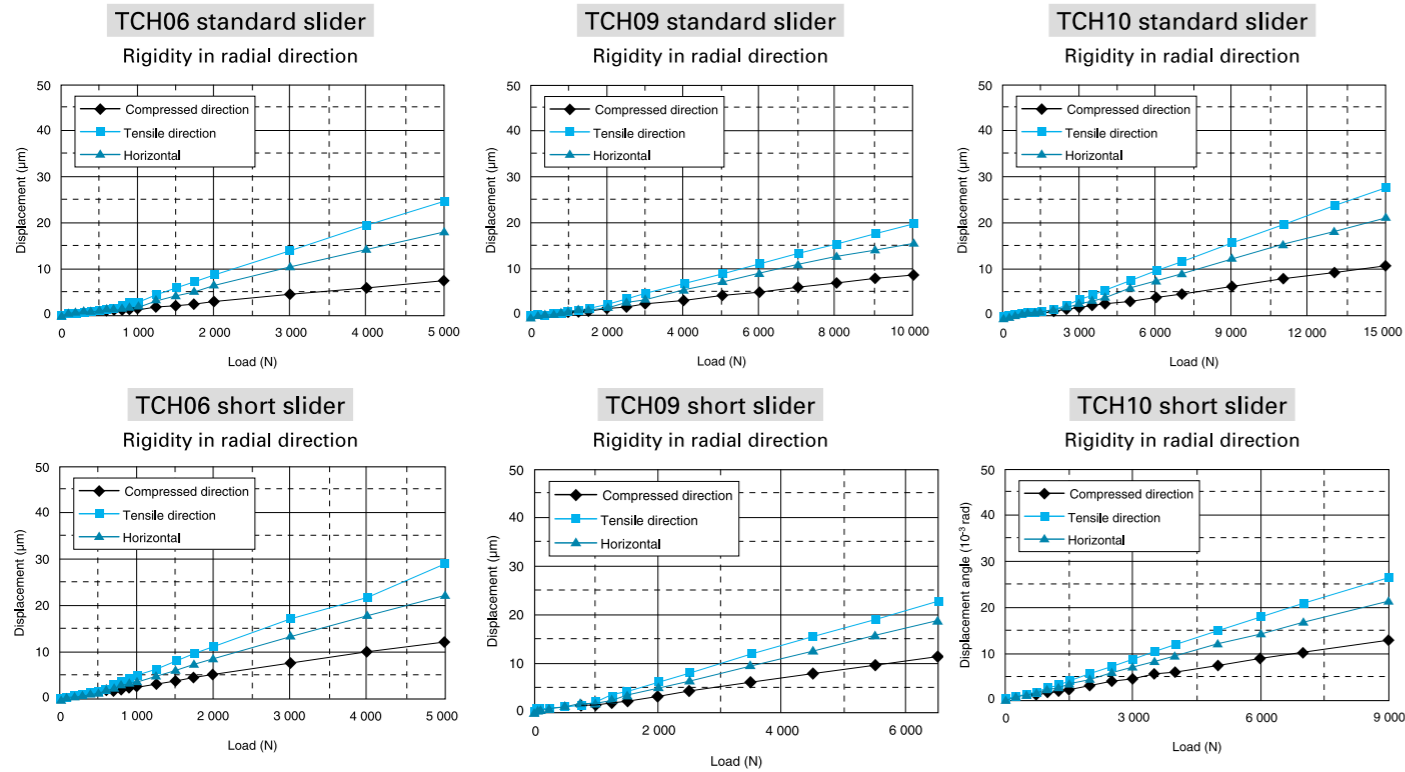

◆ Moment in radial direction

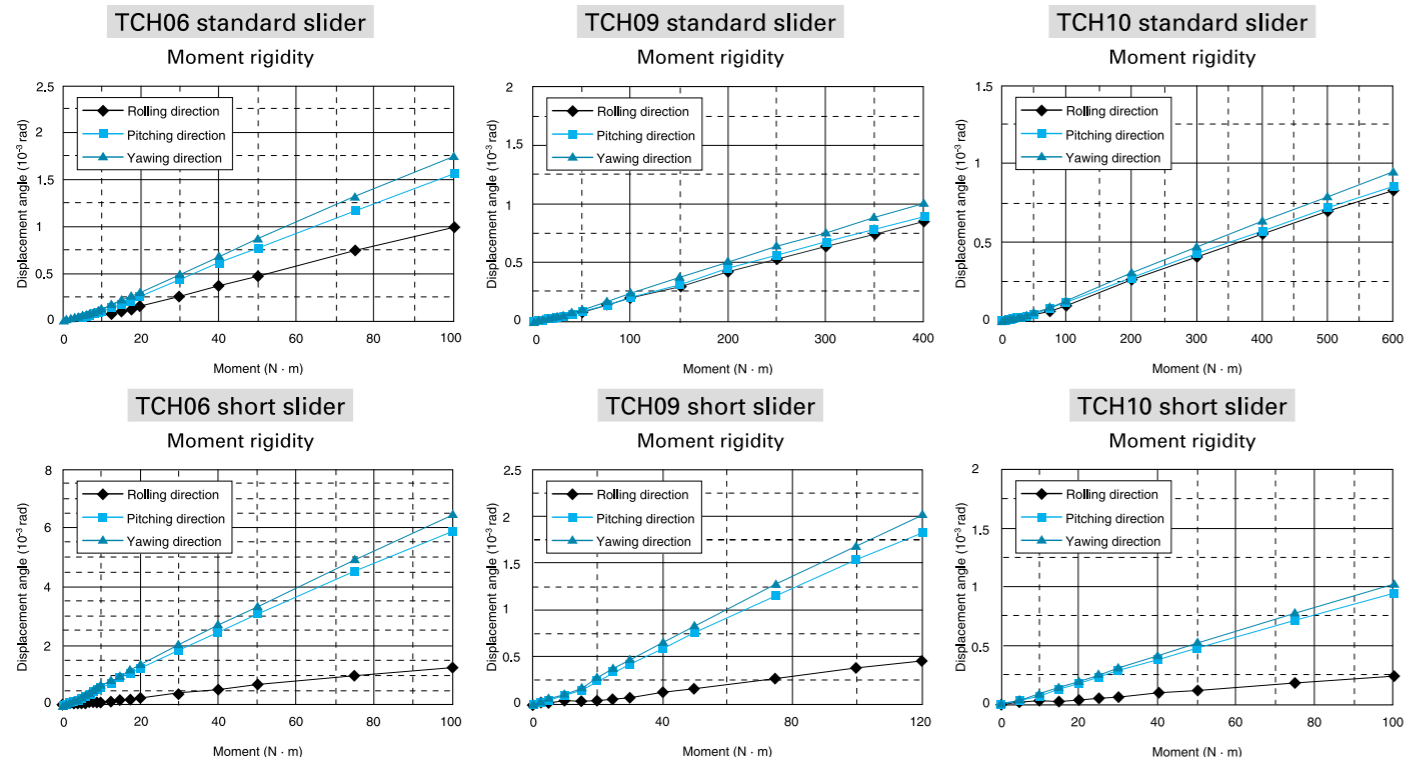

2-4. 6 Basic Load Rating

◆ Basic Load Rating for TCH series

Standard slider

Model no.	Lead l (mm)	Shaft dia. d (mm)	Basic dynamic load rating (N)			Basic static load rating (N)		Support bearing limit load (N)
			Ball screw C_a	Linear guide C	Support bearings C_a	Ball screw C_{0a}	Linear guide C_0	
TCH06	5	$\phi 12$	3 760	20 900	6 600	6 310	45 000	2 700
	10		2 260			3 780		
	20		2 260			3 780		
TCH09	5	$\phi 15$	7 100	44 900	8 800	13 000	96 900	5 090
	10		7 060			12 700		
	20		4 560			7 750		
TCH10	10	$\phi 20$	10 900	62 400	9 600	21 700	132 000	5 670
	10		7 060			12 700		
	20		7 060			12 700		

Short slider

Model no.	Lead l (mm)	Shaft dia. d (mm)	Basic dynamic load rating (N)			Basic static load rating (N)		Support bearing limit load (N)
			Ball screw C_a	Linear guide C	Support bearings C_a	Ball screw C_{0a}	Linear guide C_0	
TCH06	5	$\phi 12$	3 760	12 200	6 600	6 310	22 500	2 700
	10		2 260			3 780		
TCH09	5	$\phi 15$	7 100	27 900	8 800	13 000	52 500	5 090
	10		7 060			12 700		
TCH10	10	$\phi 20$	10 900	38 700	9 600	21 700	71 500	5 670
	20		7 060			12 700		

- Basic dynamic and static load ratings indicate values for one slider.
- Basic dynamic load rating of linear guide is a load that allows for a 50-km rating fatigue life and is a vertical and constant load on the ball mounting surface.
- Basic dynamic load rating of ball screw is load in the axial direction that allows 90% of ball screws of a group of the same Toughcarriers to rotate 1 million revolutions under the same condition without causing flaking by rolling contact fatigue.
- Basic dynamic load rating of support bearings is load that allows 1 million revolutions under the same condition.
- Basic static load rating is load that results in combined permanent deformations at contact points of rolling elements and rolling surfaces of respective parts at a diameter of 0.01%.

◆ Basic static moment load of linear guide

Standard slider

Model no.	Slider	Basic static moment load (N·m)		
		Rolling M_{RO}	Pitching M_{PO}	Yawing M_{YO}
TCH06	Single	800	340	340
TCH09	Single	2 510	1 340	1 340
TCH10	Single	3 980	2 150	2 150

Short slider

Model no.	Slider	Basic static moment load (N·m)		
		Rolling M_{RO}	Pitching M_{PO}	Yawing M_{YO}
TCH06	Single	400	85	85
TCH09	Single	1 350	390	390
TCH10	Single	2 150	630	630

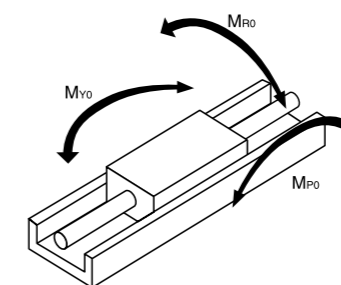

M_{RO} : Rolling moment
 M_{PO} : Pitching moment
 M_{YO} : Yawing moment

2-4. 7 Estimation of Life Expectancy

(1) Life of linear guide for Toughcarrier

Study the load to be applied to the linear guide of Toughcarrier (Fig. 1). The equivalent load (Fe) is determined by substituting the load for equation 1) (Eq. 2) or 2') for tightly coupled double slider type).

● For single slider

$$Fe = Y_H \cdot F_H + Y_V \cdot F_V + Y_R \cdot \epsilon_R \cdot M_R + Y_P \cdot \epsilon_P \cdot M_P + Y_Y \cdot \epsilon_Y \cdot M_Y \dots\dots\dots 1)$$

● For double slider

For double sliders, calculation of the load applied to each slider is required.

Dynamic equivalent load is only for rolling moment.

This is the same procedure as for linear guide selection where two sliders are installed in a rail. Check the mean load for each slider, and calculate shortest life becomes the life of linear guide.

When lateral direction (F_H) and vertical direction (F_V) loads are applied to the center of the coordinate in Fig. 1,

$$F_{HA} = \frac{F_H}{2} + \frac{M_Y}{l}, F_{VA} = \frac{F_V}{2} + \frac{M_P}{l}$$

$$F_{HB} = \frac{F_H}{2} - \frac{M_Y}{l}, F_{VB} = \frac{F_V}{2} - \frac{M_P}{l}$$

[Slider A]

$$Fe_A = Y_H \cdot F_{HA} + Y_V \cdot F_{VA} + Y_R \epsilon_R \frac{M_R}{2} \dots\dots\dots 2)$$

$$= Y_H \left(\frac{F_H}{2} + \frac{M_Y}{l} \right) + Y_V \left(\frac{F_V}{2} + \frac{M_P}{l} \right) + Y_R \epsilon_R \frac{M_R}{2}$$

[Slider B]

$$Fe_B = Y_H \cdot F_{HB} + Y_V \cdot F_{VB} + Y_R \epsilon_R \frac{M_R}{2} \dots\dots\dots 2)'$$

$$= Y_H \left(\frac{F_H}{2} - \frac{M_Y}{l} \right) + Y_V \left(\frac{F_V}{2} - \frac{M_P}{l} \right) + Y_R \epsilon_R \frac{M_R}{2}$$

F_H : Lateral direction load acting on the slider (N)

F_V : Vertical direction load acting on the slider (N)

M_R : Rolling moment acting on the slider (N · m)

M_P : Pitching moment acting on the slider (N · m)

M_Y : Yawing moment acting on the slider (N · m)

ε_R : Dynamic equivalent coefficient to rolling moment

ε_P : Dynamic equivalent coefficient to pitching moment

ε_Y : Dynamic equivalent coefficient to yawing moment

l : Sliders span

*For dynamic equivalent coefficient, see table 1.

Y_{Hr}, Y_{Vr}, Y_{Rr}, Y_{Pr}, Y_{Yr}: 1.0 or 0.5

At equations 1), 2) and 2') for obtaining equivalent load Fe, the maximum value of Y in the values for each equation is assumed to be 1.0. For others it is assumed to be 0.5.

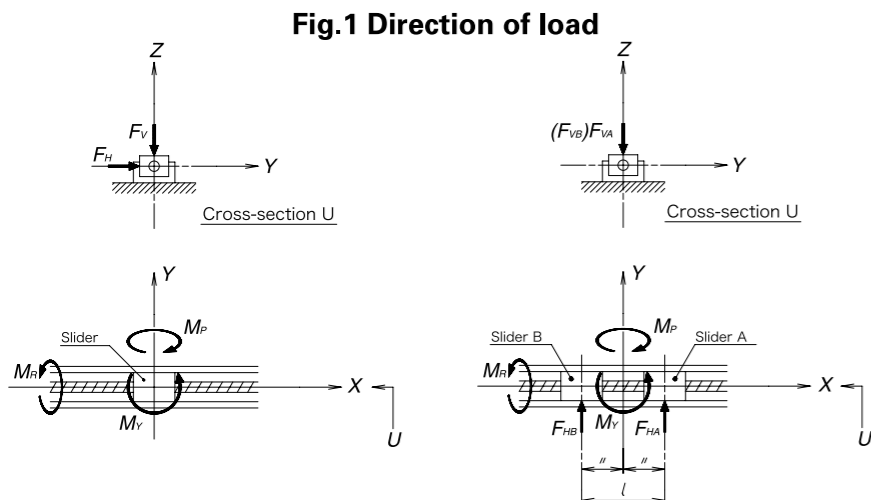
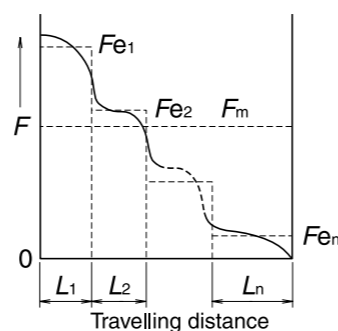

Fig.1 Direction of load

Fig. 2 Stepwise Fluctuating Load



If the loads acting on the slider fluctuate (in general, M_p and M_y may fluctuate with the acceleration/deceleration of slider), the mean effective load is determined by Eq. 3).

Travelling distance under the equivalent load Fe₁ : L₁

Travelling distance under the equivalent load Fe₂ : L₂

.....

Travelling distance under the equivalent load Fe_n : L_n

Mean effective load Fm is calculated by the following equation.

$$Fm = \sqrt[3]{\frac{1}{L} (Fe_1^{10} \cdot L_1 + Fe_2^{10} \cdot L_2 + \dots + Fe_n^{10} \cdot L_n) \dots\dots 3)}$$

Fm: Mean effective load of fluctuating loads (N)

L : Total travelling distance (mm)

The life of linear guide for Toughcarrier is determined by Eq. 4).

$$L = 50 \times \left(\frac{C}{f_w \cdot Fm} \right)^3 \dots\dots\dots 4)$$

L : Life of linear guide (km)

C : Basic dynamic load rating of linear guide (N)

Fm: Mean effective load acting on linear guide (N)

f_w : Load coefficient (see table 2)

When the estimated life does meet clear the required life, the life of the linear guide is calculated again after following measures are taken,

1: Change from single slider type to double slider type.

2: Use a larger Toughcarrier.

(2) Life of Ball Screw (Support Bearing)

The mean effective load is determined from the axial load.

Axial direction mean effective load Fm

$$Fm = \sqrt[3]{\frac{1}{L} (Fe_1^3 \cdot L_1 + Fe_2^3 \cdot L_2 + \dots + Fe_n^3 \cdot L_n) \dots\dots 5)}$$

The life of ball screw is determined by Eq. 6).

$$L = l \times \left(\frac{C_a}{f_w \cdot Fm} \right)^3 \times 10^6 \dots\dots\dots 6)$$

l : Ball screw lead (mm)

L : Life of ball screw (mm)

C_a : Basic dynamic load rating of ball screw (N)

Fm: Mean effective load acting on ball screw (N)

f_w : Load factor (see table 2)

The life of a support bearing is calculated by Eq. 6). If the life of ball screw/support bearing does not meet the required life, use a larger size Toughcarrier. After applying the calculations mentioned above, selection of the Toughcarrier is completed.

Table 2 Value of load factor

Operating conditions	Load factor f _w
At smooth operation with no mechanical shock	1.0 ~ 1.2
At normal operation	1.2 ~ 1.5
At operation with mechanical shock and vibration	1.5 ~ 3.0

*When the bottom of rail is not fastened, the load factor is 1.5 or greater.

Table 1 Dynamic equivalent coefficient

	TCH06			TCH09			TCH10		
	Rolling	Pitching	Yawing	Rolling	Pitching	Yawing	Rolling	Pitching	Yawing
Standard slider	56	93	93	39	51	51	33	44	44
Short slider	56	186	186	39	95	95	33	80	80

2-4. 8 Example of Life Estimation

Example of life estimation for Toughcarrier

Example-1

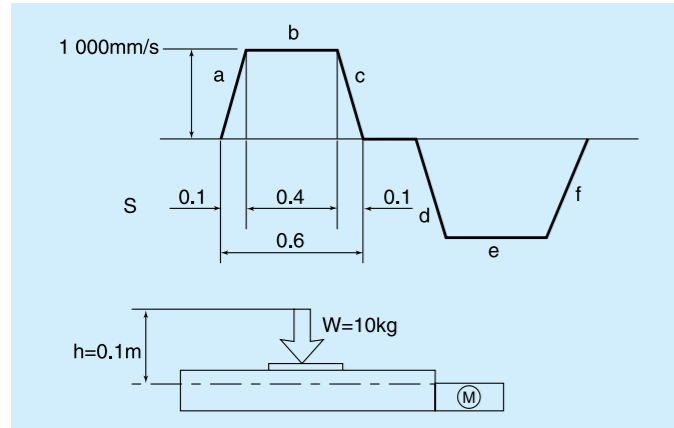

1. Use condition

- Stroke : 500 mm
- Maximum speed : 1 000 mm/s
- Load mass : $W = 10 \text{ kg}$
- Acceleration : 9.80 m/s^2
- Setting position : Horizontal
- Operating profile : See figure to above

2. Selection of model number (interim selection)
 First, select a greater ball screw lead as the maximum speed is 1 000 mm/s.
 The interim selection is TCH06050H20K00, a single slider specification TCH06 that has 500 mm stroke, as the stroke is 500 mm.

3. Calculation

3-1. Linear guide

3-1-1. Fatigue life: Multiply the result of Eq. 1) by the dynamic equivalent coefficient (**Table 1** single slider) to convert the load volume. From operation profile in the above figure, the acceleration is 10 m/s^2 .

i) Constant speed

$$F_{e1} = Y_V \cdot F_V = Y_V \cdot W \cdot g = 1 \cdot 10 \cdot 9.8 = 98 \text{ N}$$

ii) Accelerating

$$F_{e2} = Y_V \cdot F_V + Y_P \cdot \epsilon_P \cdot M_P = Y_V \cdot W \cdot g + Y_P \cdot \epsilon_P \cdot h \cdot W \cdot \alpha = 0.5 \cdot 10 \cdot 9.8 + 1 \cdot 93 \cdot 0.1 \cdot 10 \cdot 10 = 979 \text{ N}$$

iii) Decelerating

$$F_{e3} = Y_V \cdot F_V + Y_P \cdot \epsilon_P \cdot M_P = 0.5 \cdot 10 \cdot 9.8 + 1 \cdot 93 \cdot 0.1 \cdot 10 \cdot 10 = 979 \text{ N}$$

Mean effective load F_m

$$F_m = \sqrt[10]{\frac{1}{L} (F_{e1}^{10} \cdot L_1 + F_{e2}^{10} \cdot L_2 + F_{e3}^{10} \cdot L_3)}$$

$$= \sqrt[10]{\frac{1}{500} (98^{10} \cdot 400 + 979^{10} \cdot 50 + 979^{10} \cdot 50)}$$

$$= 605 \text{ N}$$

$$L = 50 \times \left(\frac{C}{f_w \cdot F_m} \right)^{\frac{10}{3}}$$

$$= 50 \times \left(\frac{20\,900}{1.2 \cdot 605} \right)^{\frac{10}{3}}$$

$$= 3.65 \times 10^6 \text{ km}$$

3-1-2. Static safety factor: Divide the basic static load rating by the maximum load.

$$F_s = \frac{C_0}{F_e} = \frac{C_0}{F_{e2}} = \frac{45\,000}{979} = 45.9$$

3-2. Ball screw

3-2-1. Fatigue life: Obtain the axial load of each stage of operation referring to the operation profile, and then calculate the mean load.

By the process above,

i) Constant speed

$$F_{e1} = \mu \cdot W \cdot g = 0.01 \cdot 10 \cdot 9.8 = 0.98 \text{ N}$$

ii) Accelerating

$$F_{e2} = F_{e1} + W \cdot \alpha = 0.98 + 10 \cdot 10 = 101 \text{ N}$$

iii) Decelerating

$$F_{e3} = F_{e1} + W \cdot \alpha = 0.98 - 10 \cdot 10 = 99 \text{ N}$$

Axial mean effective load

$$F_m = \sqrt[3]{\frac{1}{L} (F_{e1}^3 \cdot L_1 + F_{e2}^3 \cdot L_2 + F_{e3}^3 \cdot L_3)}$$

$$= \sqrt[3]{\frac{1}{500} (0.98^3 \cdot 400 + 101^3 \cdot 50 + 99^3 \cdot 50)}$$

$$= 59 \text{ N}$$

$$L = \ell \times \left(\frac{C_a}{f_w \cdot F_m} \right)^3 \times 10^6$$

$$= 20 \times \left(\frac{2\,260}{1.2 \cdot 59} \right)^3 \times 10^6$$

$$= 6.50 \times 10^5 \text{ km}$$

3-2-2. Static safety factor: Divide the basic static load rating by the maximum axial load.

$$F_s = \frac{C_{0a}}{F_e} = \frac{C_{0a}}{F_{e2}} = \frac{3\,780}{101} = 37.4$$

3-3. Support bearings

3-3-1. Fatigue life: Use the axial load $F_m = 59 \text{ N}$ that is the result of the calculation in 3-2-1, above.

$$L = \ell \times \left(\frac{C_a}{f_w \cdot F_m} \right)^3 \times 10^6$$

$$= 20 \times \left(\frac{6\,600}{1.2 \cdot 59} \right)^3 \times 10^6$$

$$= 1.62 \times 10^7 \text{ km}$$

3-3-2. Static safety factor: Divide the limit load by the maximum axial load.

$$F_s = \frac{C_{0a}}{F_e} = \frac{C_{0a}}{F_{e2}} = \frac{2\,700}{101} = 26.7$$

3-4. Result

TCH06050H20K00	Linear guide	Ball screw	Support bearings
Fatigue life	$3.65 \times 10^6 \text{ km}$	$6.50 \times 10^5 \text{ km}$	$1.62 \times 10^7 \text{ km}$
Static safety factor	45.9	37.4	26.7

Example of life estimation

Example-2

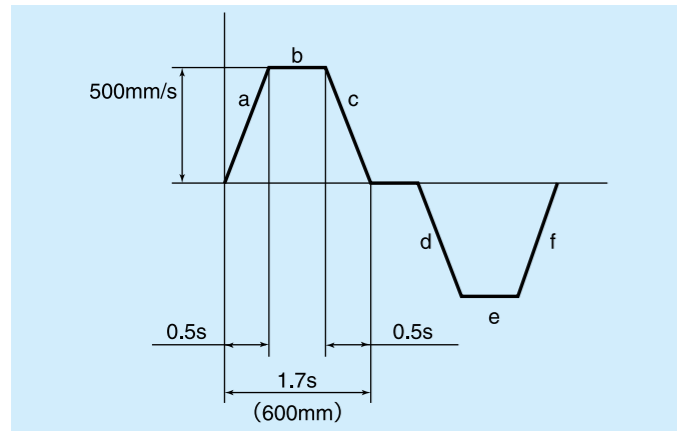

1. Use condition

- Stroke : 600 mm
- Maximum speed : 500 mm/s
- Load mass : W = 20 kg
- Acceleration : 9.8 m/s²
- Setting position : Vertical
- Operating profile : See figure to above

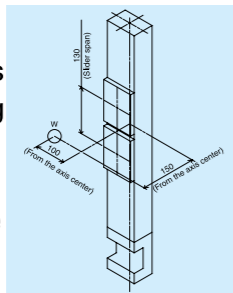

2. Selection of model number (interim selection)
 Select a 10 mm lead ball screw as the maximum speed is 500 mm/s.
 The interim selection is TCH09067H10D00 (double slider specification) from the stroke and the vertical setting position.

3. Calculation

3-1. Linear guide
 3-1-1. Fatigue life: Multiply the result of Eq. 2) and 2') by the dynamic equivalent coefficient (Table 1 double slider) to convert the load volume. From operation profile in the above figure, the acceleration is 1 m/s². The interim slider span is 0.13.

Under this condition,
 $F_H = 0, F_V = 0, M_R = 0$
 in Eq., and both sliders have the same load with different direction.

i) Constant speed

$$F_{e1} = Y_H \cdot \frac{M_Y}{l} + Y_V \cdot \frac{M_P}{l}$$

$$= 0.5 \cdot \frac{0.1 \cdot 20 \cdot 9.8}{0.13} + 1.0 \cdot \frac{0.15 \cdot 20 \cdot 9.8}{0.13}$$

$$= 302 \text{ N}$$

ii) Accelerating

$$F_{e2} = Y_H \cdot \frac{M_Y}{l} + Y_V \cdot \frac{M_P}{l}$$

$$= 0.5 \cdot \frac{0.1 \cdot 20 \cdot (9.8 + 1.0)}{0.13} + 1.0 \cdot \frac{0.15 \cdot 20 \cdot (9.8 + 1.0)}{0.13}$$

$$= 333 \text{ N}$$

iii) Decelerating

$$F_{e3} = Y_H \cdot \frac{M_Y}{l} + Y_V \cdot \frac{M_P}{l}$$

$$= 0.5 \cdot \frac{0.1 \cdot 20 \cdot (9.8 - 1.0)}{0.13} + 1.0 \cdot \frac{0.15 \cdot 20 \cdot (9.8 - 1.0)}{0.13}$$

$$= 271 \text{ N}$$

Mean effective load F_m

$$F_m = \sqrt[10]{\frac{1}{L} (F_{e1}^{10} \cdot L_1 + F_{e2}^{10} \cdot L_2 + F_{e3}^{10} \cdot L_3)}$$

$$= \sqrt[10]{\frac{1}{600} (302^{10} \cdot 350 + 333^{10} \cdot 125 + 271^{10} \cdot 125)}$$

$$= 304 \text{ N}$$

$$L = 50 \times \left(\frac{C}{f_w \cdot F_m} \right)^{\frac{10}{3}}$$

$$= 50 \times \left(\frac{44\,900}{1.2 \cdot 304} \right)^{\frac{10}{3}}$$

$$= 4.63 \times 10^8 \text{ km}$$

3-1-2. Static safety factor: Divide the basic static load rating by the maximum load.

$$F_s = \frac{C_0}{F_e} = \frac{C_0}{F_{e2}} = \frac{96\,900}{333} = 290$$

3-2. Ball screw

3-2-1. Fatigue life: Obtain the axial load of each stage of operation referring to the operation profile, and then calculate the mean load.

i) Constant speed
 $F_{e1} = W \cdot g = 20 \cdot 9.8 = 196 \text{ N}$

ii) Accelerating
 $F_{e2} = F_{e1} + W \cdot \alpha = 196 + 20 \cdot 1.0 = 216 \text{ N}$

iii) Decelerating
 $F_{e3} = F_{e1} - W \cdot \alpha = 196 - 20 \cdot 1.0 = 176 \text{ N}$

Axial mean effective load F_m

$$F_m = \sqrt[3]{\frac{1}{L} (F_{e1}^3 \cdot L_1 + F_{e2}^3 \cdot L_2 + F_{e3}^3 \cdot L_3)}$$

$$= \sqrt[3]{\frac{1}{600} (196^3 \cdot 350 + 216^3 \cdot 125 + 176^3 \cdot 125)}$$

$$= 197 \text{ N}$$

$$L = l \times \left(\frac{C_a}{f_w \cdot F_m} \right)^3 \times 10^6$$

$$= 10 \times \left(\frac{7\,060}{1.2 \cdot 197} \right)^3 \times 10^6$$

$$= 2.66 \times 10^5 \text{ km}$$

3-2-2. Static safety factor: Divide the basic static load rating by the maximum axial load.

$$F_s = \frac{C_{0a}}{F_e} = \frac{C_{0a}}{F_{e2}} = \frac{12\,700}{216} = 58.7$$

3-3. Support bearings

3-3-1. Fatigue life: Use the axial load $F_m = 197 \text{ N}$ that is the result of the calculation in 3-2-1, above.

$$L = l \times \left(\frac{C_a}{f_w \cdot F_m} \right)^3 \times 10^6$$

$$= 10 \times \left(\frac{8\,800}{1.2 \cdot 197} \right)^3 \times 10^6$$

$$= 5.15 \times 10^5 \text{ km}$$

3-3-2. Static safety factor: Divide the limit load by the maximum axial load.

$$F_s = \frac{C_{0a}}{F_e} = \frac{C_{0a}}{F_{e2}} = \frac{5\,090}{216} = 23.5$$

3-4. Result

TCH09067H10D00	Linear guide	Ball screw	Support bearings
Fatigue life	4.63 × 10 ⁸ km	2.66 × 10 ⁵ km	5.15 × 10 ⁵ km
Static safety factor	290	58.7	23.5

2-5. 2 TCH09 Series

◆ TCH09 Standard Slider Specifications (with pin holes)

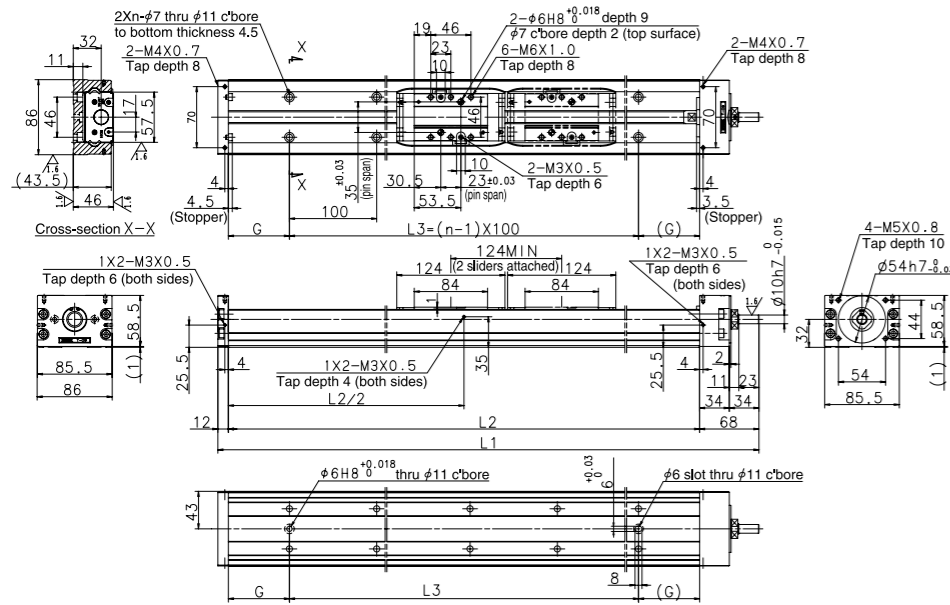

Toughcarrier dynamic torque specifications Unit: N · cm

Model no.	Slider specifications	Ball screw lead (mm)	Accuracy grade	
			High grade	Precision grade
TCH09	Single standard slider	5	2.8 ~ 7.7	4.2 ~ 12.8
		10	3.7 ~ 9.5	4.5 ~ 15.1
		20	3.7 ~ 12.6	5.1 ~ 17.9
	Double standard sliders	5	3.2 ~ 8.7	4.5 ~ 14.1
		10	4.2 ~ 12.6	5.1 ~ 17.9
		20	5.7 ~ 18.9	6.3 ~ 23.3

◆ TCH09 Short Slider Specifications (with pin holes)

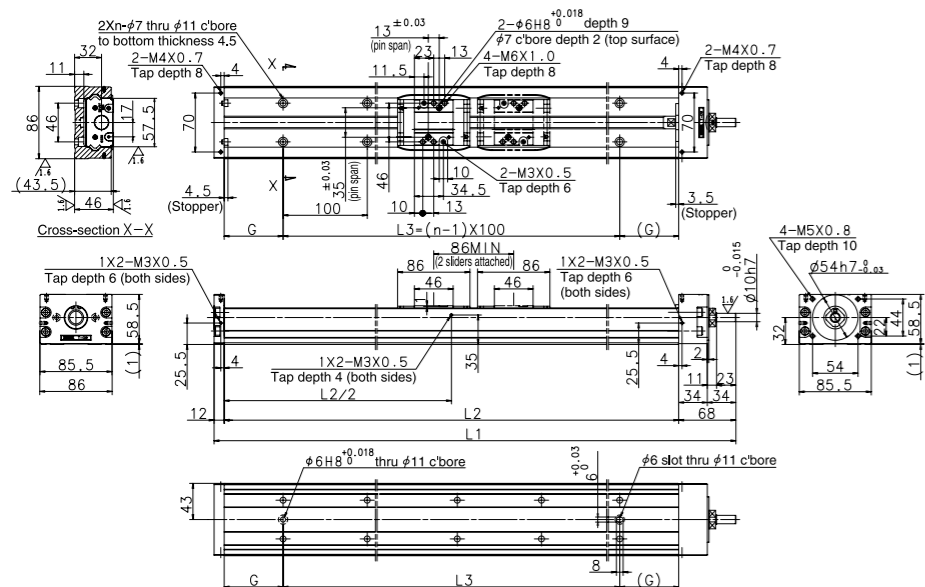

Toughcarrier dynamic torque specifications Unit: N · cm

Model no.	Slider specifications	Ball screw lead (mm)	Accuracy grade	
			High grade	Precision grade
TCH09	Single short slider	5	2.0 ~ 6.9	3.5 ~ 12.0
		10	2.9 ~ 8.7	3.8 ~ 14.3
		20	2.9 ~ 11.8	4.3 ~ 17.1
	Double short sliders	5	2.5 ~ 7.9	3.8 ~ 13.3
		10	3.4 ~ 11.8	4.3 ~ 17.1
		20	4.9 ~ 18.1	5.5 ~ 22.6

TCH09 Standard Slider Specifications (Single)

Reference number	Nominal stroke (mm)	Stroke limit (mm)	Ball screw lead (mm)	Body length (mm)				No. of mounting holes n	Inertia x 10 ⁻⁶ (kg · m ²)	Mass (kg)
				L ₁	L ₂	L ₃	G			
* TCH09010H05K00 (01)	100	108	5	320	240	100	70	2	9.13	6.5
* TCH09010H10K00 (01)			10						11.0	
* TCH09010H20K00 (01)			20						18.6	
TCH09020H05K00 (01)	200	208	5	420	340	200	70	3	14.2	7.9
TCH09020H10K00 (01)			10						16.0	
TCH09020H20K00 (01)			20						23.6	
TCH09030H05K00 (01)	300	308	5	520	440	300	70	4	18.1	9.4
TCH09030H10K00 (01)			10						19.9	
TCH09030H20K00 (01)			20						27.5	
TCH09040H05K00 (01)	400	408	5	620	540	400	70	5	21.9	10.8
TCH09040H10K00 (01)			10						23.8	
TCH09040H20K00 (01)			20						31.4	
TCH09050H05K00 (01)	500	508	5	720	640	500	70	6	25.9	12.3
TCH09050H10K00 (01)			10						27.7	
TCH09050H20K00 (01)			20						35.3	
TCH09060H05K00 (01)	600	608	5	820	740	600	70	7	29.4	13.6
TCH09060H10K00 (01)			10						31.3	
TCH09060H20K00 (01)			20						38.9	
TCH09070H05K00 (01)	700	708	5	920	840	700	70	8	33.5	15.0
TCH09070H10K00 (01)			10						35.4	
TCH09070H20K00 (01)			20						43.0	
TCH09080H05K00 (01)	800	808	5	1 020	940	800	70	9	37.4	16.4
TCH09080H10K00 (01)			10						39.3	
TCH09080H20K00 (01)			20						46.9	

Items marked with * are unavailable for upside-down operation.

TCH09 Standard Slider Specifications (Double)

Reference number	Nominal stroke (mm)	Stroke limit (mm)	Ball screw lead (mm)	Body length (mm)				No. of mounting holes n	Inertia x 10 ⁻⁶ (kg · m ²)	Mass (kg)
				L ₁	L ₂	L ₃	G			
* TCH09017H05D00 (01)	170	184	5	520	440	300	70	4	19.47	10.3
* TCH09017H10D00 (01)			10						22.89	
* TCH09017H20D00 (01)			20						26.77	
* TCH09027H05D00 (01)	270	284	5	620	540	400	70	5	23.35	11.7
* TCH09027H10D00 (01)			10						26.77	
* TCH09027H20D00 (01)			20						33.5	
TCH09037H05D00 (01)	370	384	5	720	640	500	70	6	27.22	13.2
TCH09037H10D00 (01)			10						30.64	
TCH09037H20D00 (01)			20						36.55	
TCH09047H10D00 (01)	470	484	10	820	740	600	70	7	34.55	14.5
TCH09047H20D00 (01)			20						48.24	
TCH09067H10D00 (01)			10						42.27	
TCH09067H20D00 (01)	20	55.96	1 020	940	800	70	9	55.96	17.3	

Items marked with * are unavailable for upside-down operation.

TCH09 Short Slider Specifications (Single)

Reference number	Nominal stroke (mm)	Stroke limit (mm)	Ball screw lead (mm)	Body length (mm)				No. of mounting holes n	Inertia x 10 ⁻⁶ (kg · m ²)	Mass (kg)
				L ₁	L ₂	L ₃	G			
* TCH09014H05A00 (01)	140	146	5	320	240	100	70	2	8.9	6.1
* TCH09014H10A00 (01)			10						10.1	
* TCH09014H20A00 (01)			20						14.6	
TCH09024H05A00 (01)	240	246	5	420	340	200	70	3	13.9	7.5
TCH09024H10A00 (01)			10						15.1	
TCH09024H20A00 (01)			20						19.6	
TCH09034H05A00 (01)	340	346	5	520	440	300	70	4	17.8	9.0
TCH09034H10A00 (01)			10						18.9	
TCH09034H20A00 (01)			20						23.5	
TCH09044H05A00 (01)	440	446	5	620	540	400	70	5	21.7	10.4
TCH09044H10A00 (01)			10						22.8	
TCH09044H20A00 (01)			20						27.4	
TCH09054H05A00 (01)	540	546	5	720	640	500	70	6	25.6	11.9
TCH09054H10A00 (01)			10						26.7	
TCH09054H20A00 (01)			20						31.3	
TCH09064H05A00 (01)	640	646	5	820	740	600	70	7	29.2	13.2
TCH09064H10A00 (01)			10						30.3	
TCH09064H20A00 (01)			20						34.9	
TCH09074H05A00 (01)	740	746	5	920	840	700	70	8	33.3	14.6
TCH09074H10A00 (01)			10						34.4	
TCH09074H20A00 (01)			20						39.9	
TCH09084H05A00 (01)	840	846	5	1 020	940	800	70	9	37.2	16.0
TCH09084H10A00 (01)			10						38.3	
TCH09084H20A00 (01)			20						42.8	

Items marked with * are unavailable for upside-down operation.

TCH09 Short Slider Specifications (Double)

Reference number	Nominal stroke (mm)	Stroke limit (mm)	Ball screw lead (mm)	Body length (mm)				No. of mounting holes n	Inertia x 10 ⁻⁶ (kg · m ²)	Mass (kg)
				L ₁	L ₂	L ₃	G			
TCH09025H05B00 (01)	250	260	5	520	440	300	70	4	18.96	9.5
TCH09025H10B00 (01)			10						20.86	
TCH09025H20B00 (01)			20						22.84	
TCH09035H05B00 (01)	350	360	5	620	540	400	70	5	24.74	10.9
TCH09035H10B00 (01)			10						26.71	
TCH09035H20B00 (01)			20						28.61	
TCH09045H05B00 (01)	450	460	5	720	640	500	70	6	26.71	12.4
TCH09045H10B00 (01)			10						28.61	
TCH09045H20B00 (01)			20						32.52	
TCH09055H10B00 (01)	550	560	10	820	740	600	70	7	40.13	13.7
TCH09055H20B00 (01)			20						40.13	
TCH09075H10B00 (01)			10						40.24	
TCH09075H20B00 (01)	20	47.85	1 020	940	800	70	9	47.85	16.5	

2-5. 3 TCH 10 Series

◆ TCH10 Standard Slider Specifications (with pin holes)

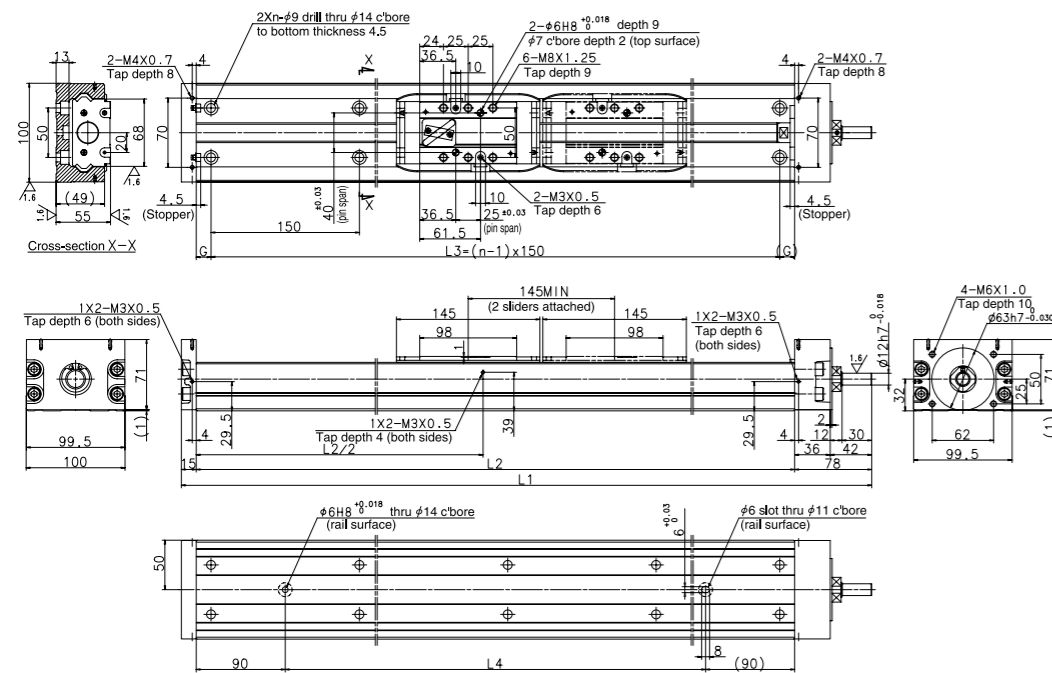

Toughcarrier dynamic torque specifications

Unit: N · cm

Model no.	Slider specifications	Ball screw lead (mm)	Accuracy grade	
			High grade	Precision grade
TCH10	Single standard slider	10	3.5 ~ 12.3	3.7 ~ 21.2
		20	4.1 ~ 16.6	4.3 ~ 25.5
	Double standard sliders	10	4.1 ~ 16.6	4.3 ~ 25.5
		20	5.4 ~ 25.2	5.6 ~ 34.1

◆ TCH10 Short Slider Specifications (with pin holes)

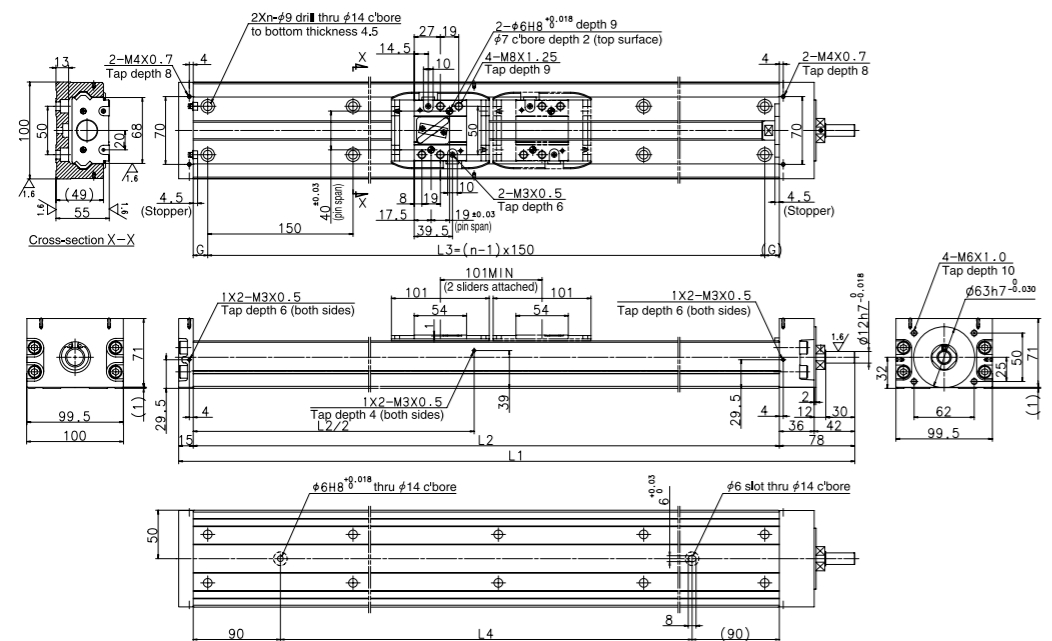

Toughcarrier dynamic torque specifications

Unit: N · cm

Model no.	Slider specifications	Ball screw lead (mm)	Accuracy grade	
			High grade	Precision grade
TCH10	Single short slider	10	3.6 ~ 11.7	3.8 ~ 20.5
		20	4.4 ~ 15.4	4.6 ~ 24.2
	Double short sliders	10	4.4 ~ 15.4	4.6 ~ 24.2
		20	6.0 ~ 22.7	6.2 ~ 31.5

TCH 10

TCH10 Standard Slider Specifications (Single)

Reference number	Nominal stroke (mm)	Stroke limit (mm)	Ball screw lead (mm)	Body length (mm)					No. of mounting holes n	Inertia $\times 10^{-6}$ (kg · m ²)	Mass (kg)
				L ₁	L ₂	L ₃	L ₄	G			
* TCH10010H10K00 (01)	100	126	10	373	280	150	100	65	2	42.72	9.6
* TCH10010H20K00 (01)			20								
TCH10020H10K00 (01)	200	226	10	473	380	300	200	40	3	54.97	11.5
TCH10020H20K00 (01)			20								
TCH10030H10K00 (01)	300	326	10	573	480	450	300	15	4	67.22	13.5
TCH10030H20K00 (01)			20								
TCH10040H10K00 (01)	400	426	10	673	580	450	400	65	4	79.47	15.4
TCH10040H20K00 (01)			20								
TCH10050H10K00 (01)	500	526	10	773	680	600	500	40	5	91.72	17.4
TCH10050H20K00 (01)			20								
TCH10060H10K00 (01)	600	626	10	873	780	750	600	15	6	104.02	19.3
TCH10060H20K00 (01)			20								
TCH10070H10K00 (01)	700	726	10	973	880	750	700	65	6	116.22	21.2
TCH10070H20K00 (01)			20								
TCH10080H10K00 (01)	800	826	10	1 073	980	900	800	40	7	128.52	23.2
TCH10080H20K00 (01)			20								
TCH10090H10K00 (01)	900	926	10	1 173	1 080	1 050	900	15	8	140.70	25.2
TCH10090H20K00 (01)			20								
TCH10100H10K00 (01)	1 000	1 026	10	1 273	1 180	1 050	1 000	65	8	152.94	27.1
TCH10100H20K00 (01)			20								
TCH10110H10K00 (01)	1 100	1 126	10	1 373	1 280	1 200	1 100	40	9	165.19	29.1
TCH10110H20K00 (01)			20								
TCH10120H10K00 (01)	1 200	1 226	10	1 473	1 380	1 350	1 200	15	10	177.43	31.1
TCH10120H20K00 (01)			20								

TCH10 Standard Slider Specifications (Double)

Items marked with * are unavailable for upside-down operation

Reference number	Nominal stroke (mm)	Stroke limit (mm)	Ball screw lead (mm)	Body length (mm)					No. of mounting holes n	Inertia $\times 10^{-6}$ (kg · m ²)	Mass (kg)
				L ₁	L ₂	L ₃	L ₄	G			
* TCH10027H10D00 (01)	270	281	10	673	580	450	400	65	4	83.02	16.8
* TCH10027H20D00 (01)			20								
* TCH10037H10D00 (01)	370	381	10	773	680	600	500	40	5	95.27	18.8
* TCH10037H20D00 (01)			20								
TCH10047H10D00 (01)	470	481	10	873	780	750	600	15	6	107.57	20.7
TCH10047H20D00 (01)			20								
TCH10057H10D00 (01)	570	581	10	973	880	750	700	65	6	119.77	22.6
TCH10057H20D00 (01)			20								
TCH10067H10D00 (01)	670	681	10	1 073	980	900	800	40	7	132.07	24.6
TCH10067H20D00 (01)			20								
TCH10077H20D00 (01)	770	781	20	1 173	1 080	1 050	900	15	8	165.54	26.6
TCH10087H20D00 (01)	870	881	20	1 273	1 180	1 050	1 000	65	8	177.78	28.5
TCH10097H20D00 (01)	970	981	20	1 373	1 280	1 200	1 100	40	9	190.03	30.5
TCH10107H20D00 (01)	1 070	1 081	20	1 473	1 380	1 350	1 200	15	10	202.27	32.5

TCH10 Short Slider Specifications (Single)

Items marked with * are unavailable for upside-down operation

Reference number	Nominal stroke (mm)	Stroke limit (mm)	Ball screw lead (mm)	Body length (mm)					No. of mounting holes n	Inertia $\times 10^{-6}$ (kg · m ²)	Mass (kg)
				L ₁	L ₂	L ₃	L ₄	G			
* TCH10016H10A00 (01)	160	170	10	373	280	150	100	65	2	41.20	8.9
* TCH10016H20A00 (01)			20								
TCH10026H10A00 (01)	260	270	10	473	380	300	200	40	3	53.45	10.9
TCH10026H20A00 (01)			20								
TCH10036H10A00 (01)	360	370	10	573	480	450	300	15	4	65.70	12.8
TCH10036H20A00 (01)			20								
TCH10046H10A00 (01)	460	470	10	673	580	450	400	65	4	77.95	14.8
TCH10046H20A00 (01)			20								
TCH10056H10A00 (01)	560	570	10	773	680	600	500	40	5	90.20	16.7
TCH10056H20A00 (01)			20								
TCH10066H10A00 (01)	660	670	10	873	780	750	600	15	6	102.50	18.6
TCH10066H20A00 (01)			20								
TCH10076H10A00 (01)	760	770	10	973	880	750	700	65	6	114.70	20.6
TCH10076H20A00 (01)			20								
TCH10086H10A00 (01)	860	870	10	1 073	980	900	800	40	7	127.00	22.6
TCH10086H20A00 (01)			20								
TCH10096H10A00 (01)	960	970	10	1 173	1 080	1 050	900	15	8	139.18	24.5
TCH10096H20A00 (01)			20								
TCH10106H10A00 (01)	1 060	1 070	10	1 273	1 180	1 050	1 000	65	8	151.42	26.5
TCH10106H20A00 (01)			20								
TCH10116H10A00 (01)	1 160	1 170	10	1 373	1 280	1 200	1 100	40	9	163.67	28.4
TCH10116H20A00 (01)			20								
TCH10126H10A00 (01)	1 260	1 270	10	1 473	1 380	1 350	1 200	15	10	175.91	30.4
TCH10126H20A00 (01)			20								

TCH10 Short Slider Specifications (Double)

Items marked with * are unavailable for upside-down operation

Reference number	Nominal stroke (mm)	Stroke limit (mm)	Ball screw lead (mm)	Body length (mm)					No. of mounting holes n	Inertia $\times 10^{-6}$ (kg · m ²)	Mass (kg)
				L ₁	L ₂	L ₃	L ₄	G			
TCH10036H10B00 (01)	360	369	10	673	580	450	400	65	4	79.97	15.6
TCH10036H20B00 (01)			20								
TCH10046H10B00 (01)	460	469	10	773	680	600	500	40	5	92.22	17.5
TCH10046H20B00 (01)			20								
TCH10056H10B00 (01)	560	569	10	873	780	750	600	15	6	104.52	19.4
TCH10056H20B00 (01)			20								
TCH10066H10B00 (01)	660	669	10	973	880	750	700	65	6	116.72	21.4
TCH10066H20B00 (01)			20								
TCH10076H10B00 (01)	760	769	10	1 073	980	900	800	40	7	129.02	23.4
TCH10076H20B00 (01)			20								
TCH10086H20B00 (01)	860	869	20	1 173	1 080	1 050	900	15	8	153.37	25.3
TCH10096H20B00 (01)	960	969	20	1 273	1 180	1 050	1 000	65	8	165.61	27.3
TCH10106H20B00 (01)	1 060	1 069	20	1 373	1 280	1 200	1 100	40	9	177.86	29.2
TCH10116H20B00 (01)	1 160	1 169	20	1 473	1 380	1 350	1 200	15	10	190.10	31.2

2-6 Accessories

2-6.1 Sensor Unit

Reference number **TC - SRH** - 1

Nominal size

Coding for model no.
 0: Proximity switch (3 b-contacts)
 1: Proximity switch (3 a-contacts)
 2: Proximity switch (1 a-contact, 2 b-contacts)
 3: Photo sensor (3 sensors)

◆ Proximity switch

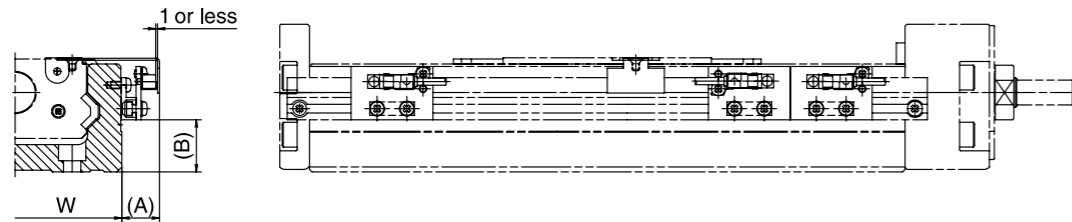

Model no.	Reference number			Dimensions		
	A (mm)	B (mm)	Body width W (mm)			
TCH06	TC-SRH06-10	TC-SRH06-11	TC-SRH06-12	17	10	60
TCH09	TC-SRH09-10	TC-SRH09-11	TC-SRH09-12	16	21	86
TCH10	TC-SRH10-10	TC-SRH10-11	TC-SRH10-12	16	25	100
Quantity	Proximity switch (a-contact)	—	3	1	E2S-W13 (OMRON Corp.)	
	Proximity switch (b-contact)	3	—	2	E2S-W14 (OMRON Corp.)	

◆ Photo sensor

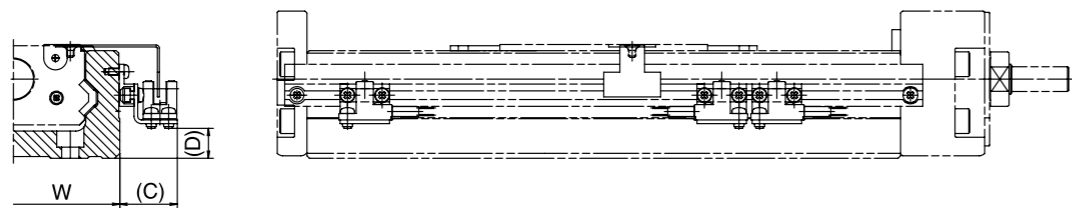

Model no.	Reference number	Dimensions			Note
		C (mm)	D (mm)	Body width W (mm)	
TCH06	TC-SRH06-13	24	2	60	EE-SX674 (OMRON Corp.) 3 sets (EE-1001 connector included)
TCH09	TC-SRH09-13	24	12	86	
TCH10	TC-SRH10-13	24	16	100	

(1) Sensor Rail

Reference number **TC - SRL**

Body rail length

Nominal no. 06→6
 09→9
 10→1

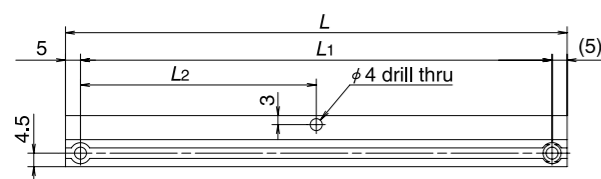

Model no.	Body rail length	Dimensions		
		L	L ₁	L ₂
TCH06	150	168	158	79
	200	218	208	104
	300	318	308	154
	400	418	408	204
	500	518	508	254
	600	618	608	304
TCH09	240	258	248	124
	340	358	348	174
	440	458	448	224
	540	558	548	274
	640	658	648	324
	740	758	748	374
TCH10	840	858	848	424
	940	958	948	474
	280	298	288	144
	380	398	388	194
	480	498	488	244
	580	598	588	294
	680	698	688	344
	780	798	788	394
	880	898	888	444
	980	998	988	494
	1 080	1 098	1 088	544
	1 180	1 198	1 188	594
1 280	1 298	1 288	644	
1 380	1 398	1 388	694	

2-6.2 Cover Unit

◆ Cover Unit
 TC-HV06XXXK00
 TC-HV06XXXD00

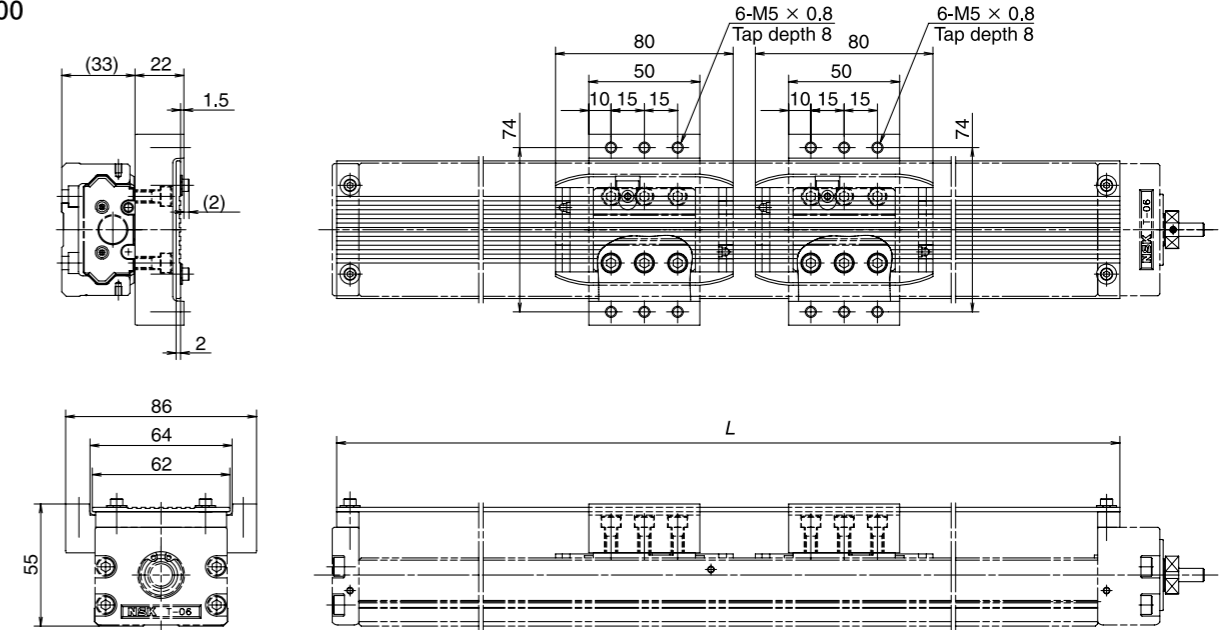

TC-HV06XXXA00
 TC-HV06XXXB00

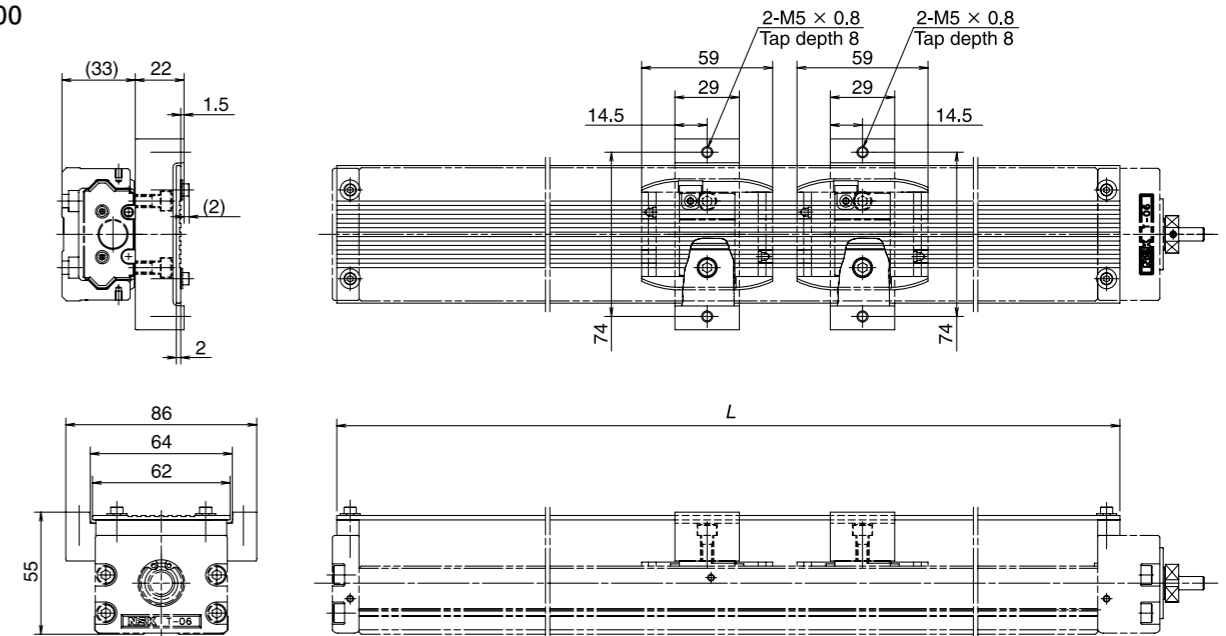

TCH06

Body rail length	Dimensions L	Slider specifications			
		Standard		Short	
		Single	Double	Single	Double
150	170	TC-HV06005K00	—	TC-HV06007A00	—
200	220	TC-HV06010K00	—	TC-HV06012A00	—
300	320	TC-HV06020K00	TC-HV06013D00	TC-HV06022A00	TC-HV06017B00
400	420	TC-HV06030K00	TC-HV06023D00	TC-HV06032A00	TC-HV06027B00
500	520	TC-HV06040K00	TC-HV06033D00	TC-HV06042A00	TC-HV06037B00
600	620	TC-HV06050K00	TC-HV06043D00	TC-HV06052A00	TC-HV06047B00

TC-HV09XXXK00
TC-HV09XXXD00

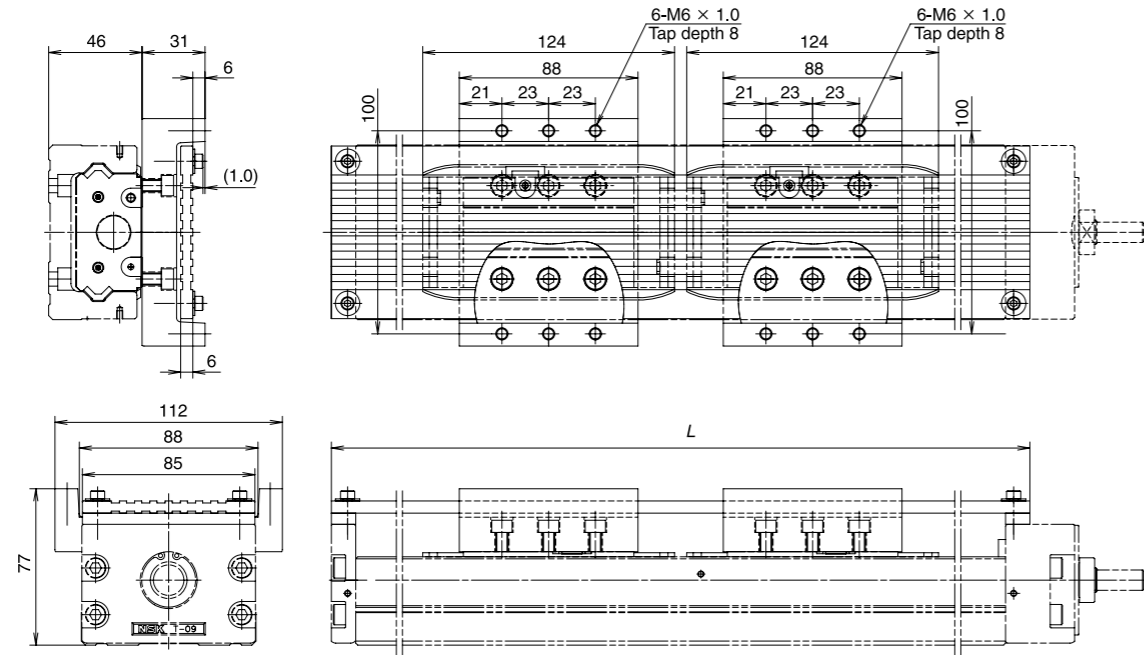

TC-HV09XXXA00
TC-HV09XXXB00

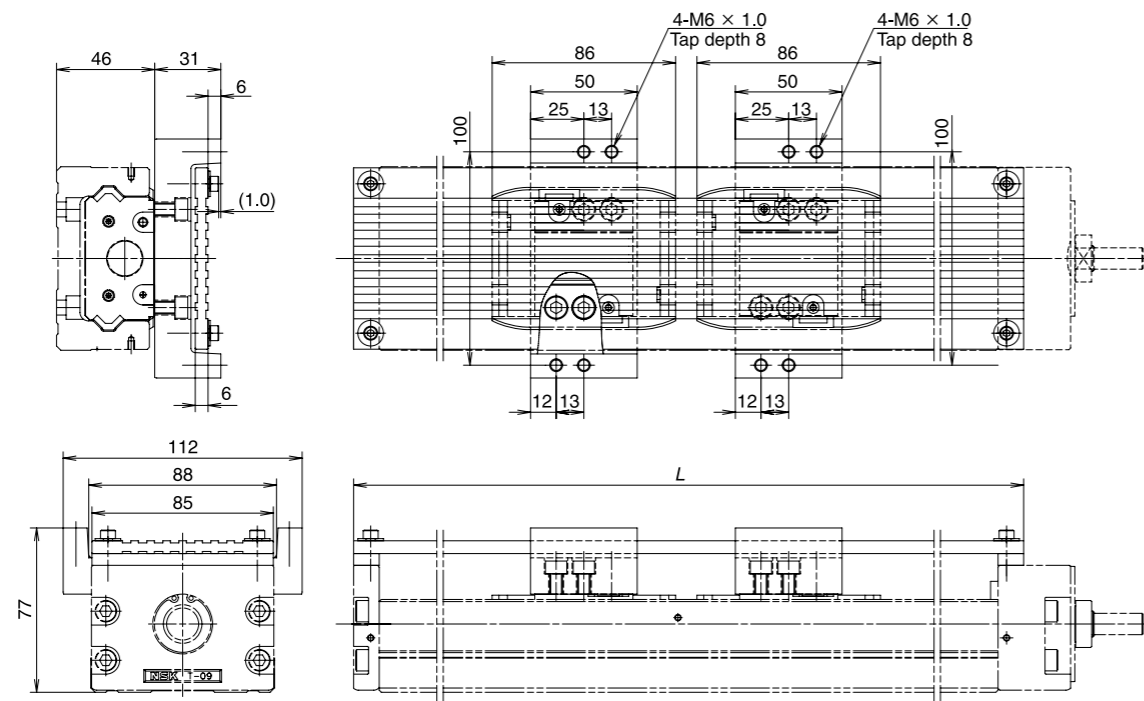

TC-HV10XXXK00
TC-HV10XXXD00

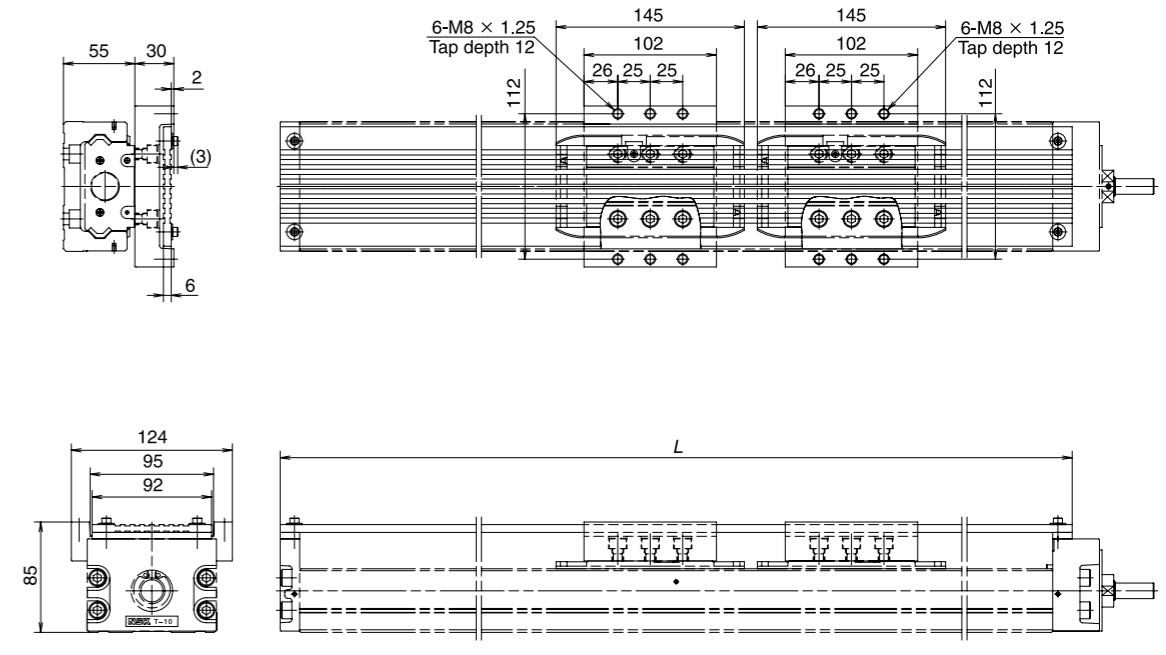

TC-HV10XXXA00
TC-HV10XXXB00

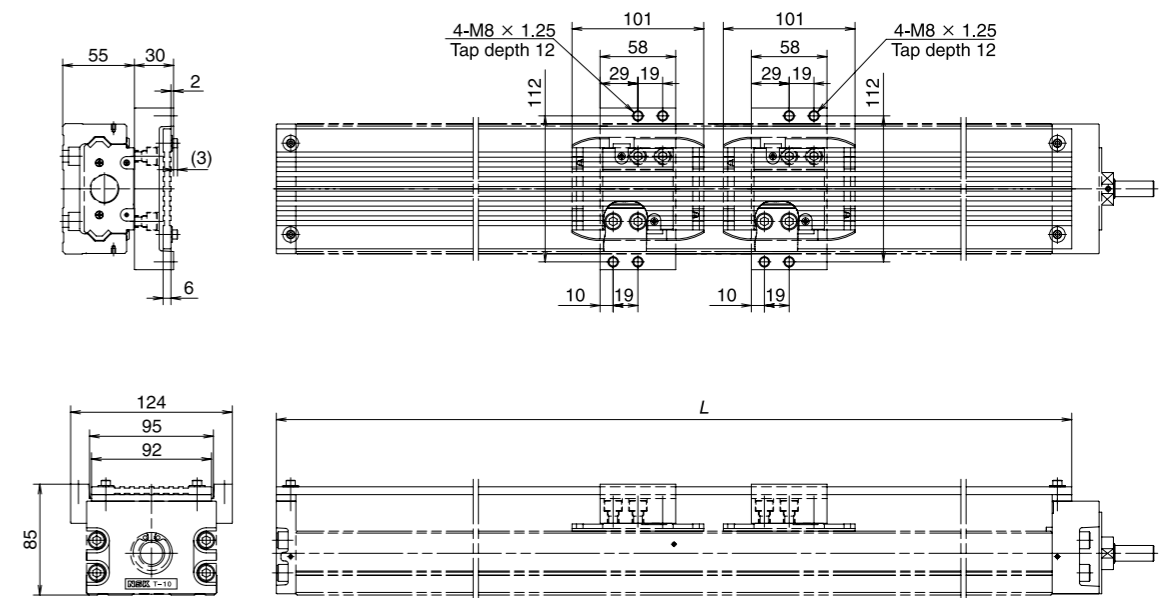

TCH09

Body rail length	Dimensions L	Slider specifications			
		Standard		Short	
		Single	Double	Single	Double
240	264	TC-HV09010K00	—	TC-HV09014A00	—
340	364	TC-HV09020K00	—	TC-HV09024A00	—
440	464	TC-HV09030K00	TC-HV09017D00	TC-HV09034A00	TC-HV09025B00
540	564	TC-HV09040K00	TC-HV09027D00	TC-HV09044A00	TC-HV09035B00
640	664	TC-HV09050K00	TC-HV09037D00	TC-HV09054A00	TC-HV09045B00
740	764	TC-HV09060K00	TC-HV09047D00	TC-HV09064A00	TC-HV09055B00
840	864	TC-HV09070K00	—	TC-HV09074A00	—
940	964	TC-HV09080K00	TC-HV09067D00	TC-HV09084A00	TC-HV09075B00

TCH10

Body rail length	Dimensions L	Slider specifications			
		Standard		Short	
		Single	Double	Single	Double
280	310	TC-HV10010K00	—	TC-HV10016A00	—
380	410	TC-HV10020K00	—	TC-HV10026A00	—
480	510	TC-HV10030K00	—	TC-HV10036A00	—
580	610	TC-HV10040K00	TC-HV10027D00	TC-HV10046A00	TC-HV10036B00
680	710	TC-HV10050K00	TC-HV10037D00	TC-HV10056A00	TC-HV10046B00
780	810	TC-HV10060K00	TC-HV10047D00	TC-HV10066A00	TC-HV10056B00
880	910	TC-HV10070K00	TC-HV10057D00	TC-HV10076A00	TC-HV10066B00
980	1 010	TC-HV10080K00	TC-HV10067D00	TC-HV10086A00	TC-HV10076B00
1 080	1 110	TC-HV10090K00	TC-HV10077D00	TC-HV10096A00	TC-HV10086B00
1 180	1 210	TC-HV10100K00	TC-HV10087D00	TC-HV10106A00	TC-HV10096B00
1 280	1 310	TC-HV10110K00	TC-HV10097D00	TC-HV10116A00	TC-HV10106B00
1 380	1 410	TC-HV10120K00	TC-HV10107D00	TC-HV10126A00	TC-HV10116B00

2-6. 3 Motor Bracket

◆ Motor bracket

Motor models are subject to change at the motor manufacturers. For details, please contact the manufacturer. For motors other than applicable motors shown below, please contact NSK.

Reference number TC-BKH06-145-00

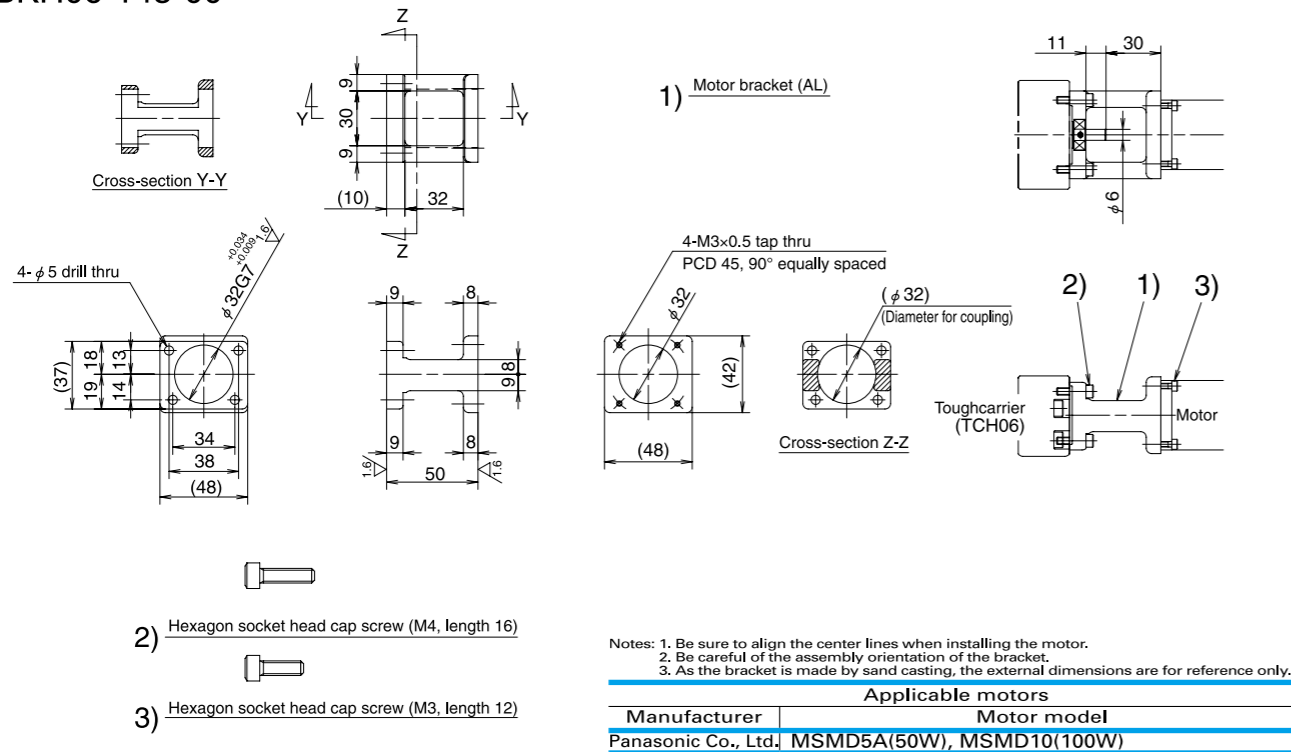

Reference number TC-BKH06-148-00

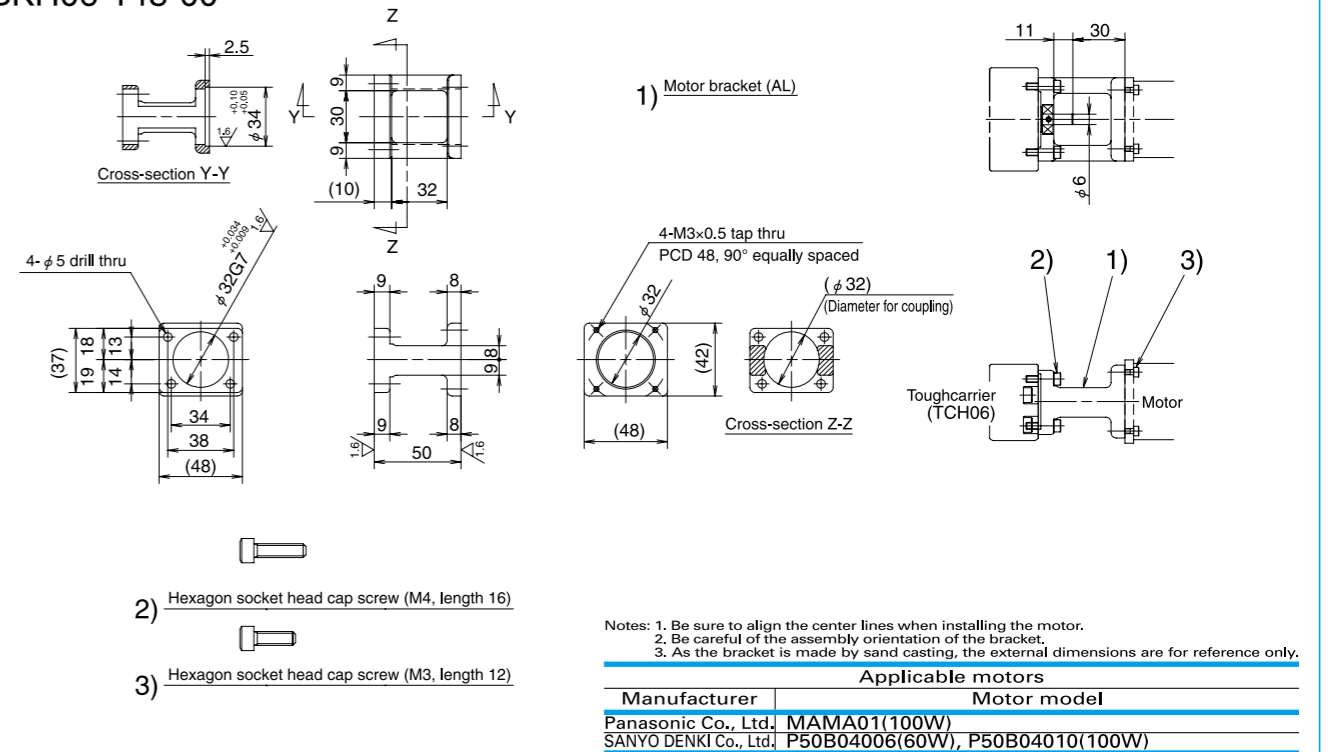

Reference number TC-BKH06-146-00

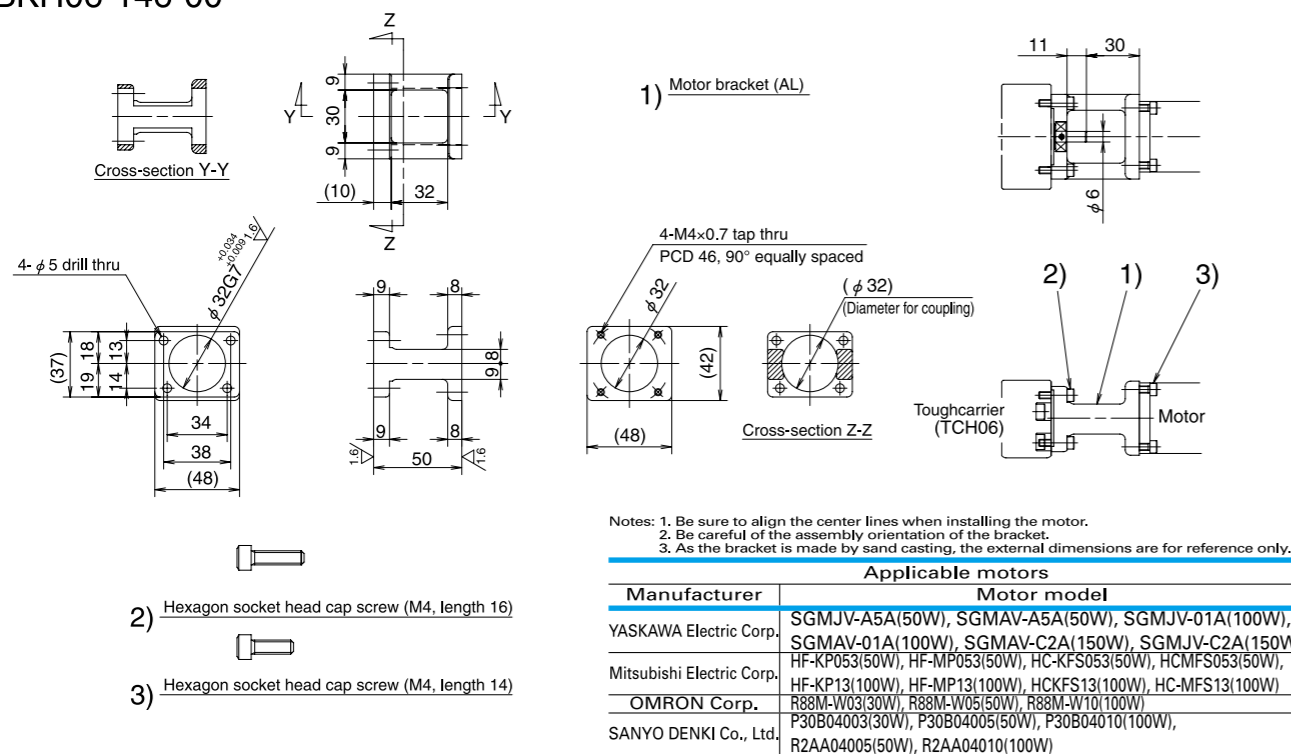

Reference number TC-BKH06-160-00

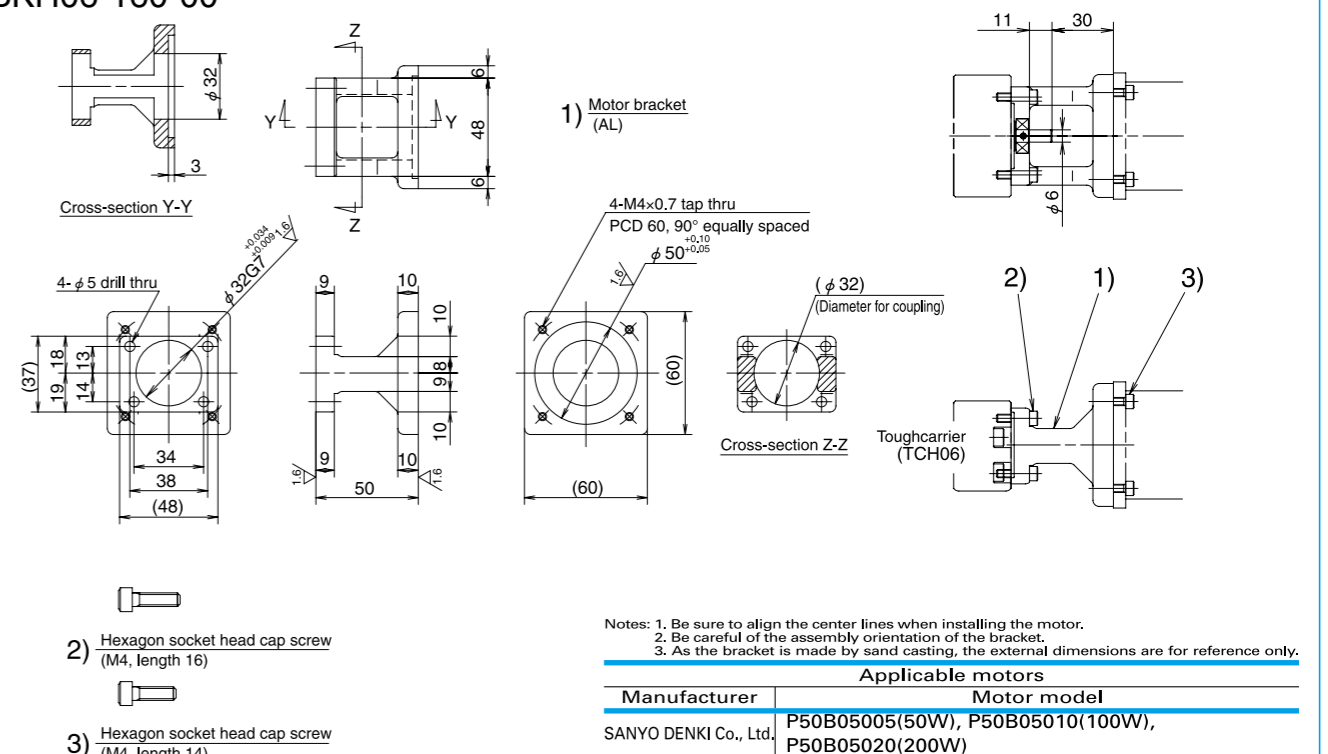

Reference number
TC-BKH09-160-00

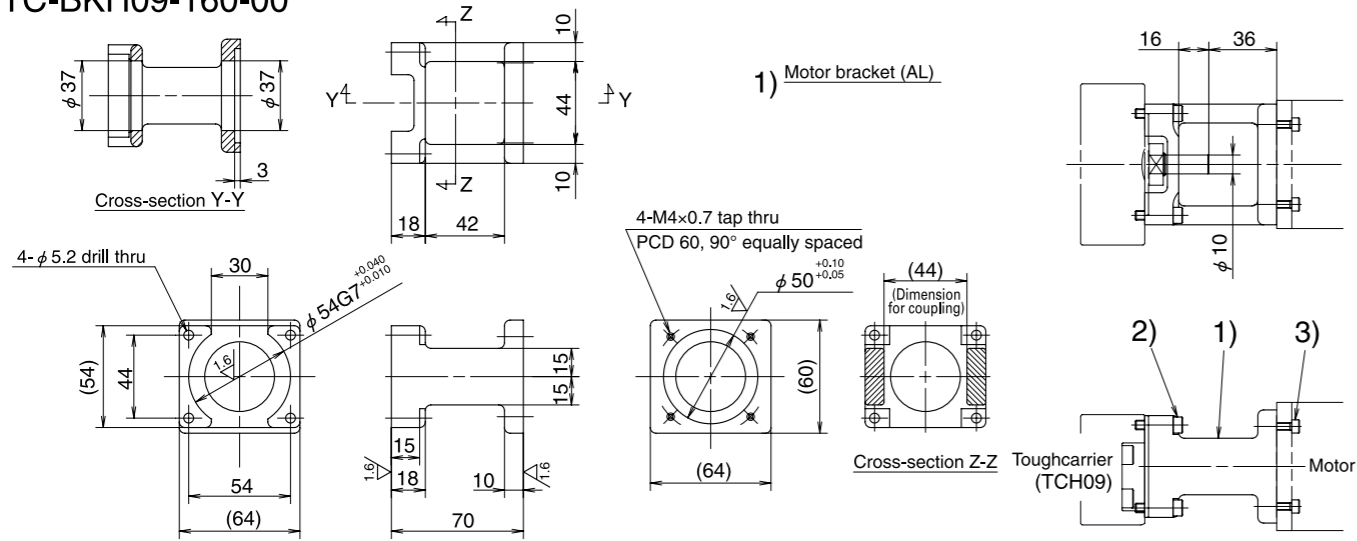

- 1) Motor bracket (AL)
- 2) Hexagon socket head cap screw (M5, length 20)
- 3) Hexagon socket head cap screw (M4, length 14)

Notes: 1. Be sure to align the center lines when installing the motor.
2. Be careful of the assembly orientation of the bracket.
3. As the bracket is made by sand casting, the external dimensions are for reference only.

Applicable motors	
Manufacturer	Motor model
SANYO DENKI Co., Ltd.	P50B05005(50W), P50B05010(100W), P50B05020(200W)

Reference number
TC-BKH09-170-01

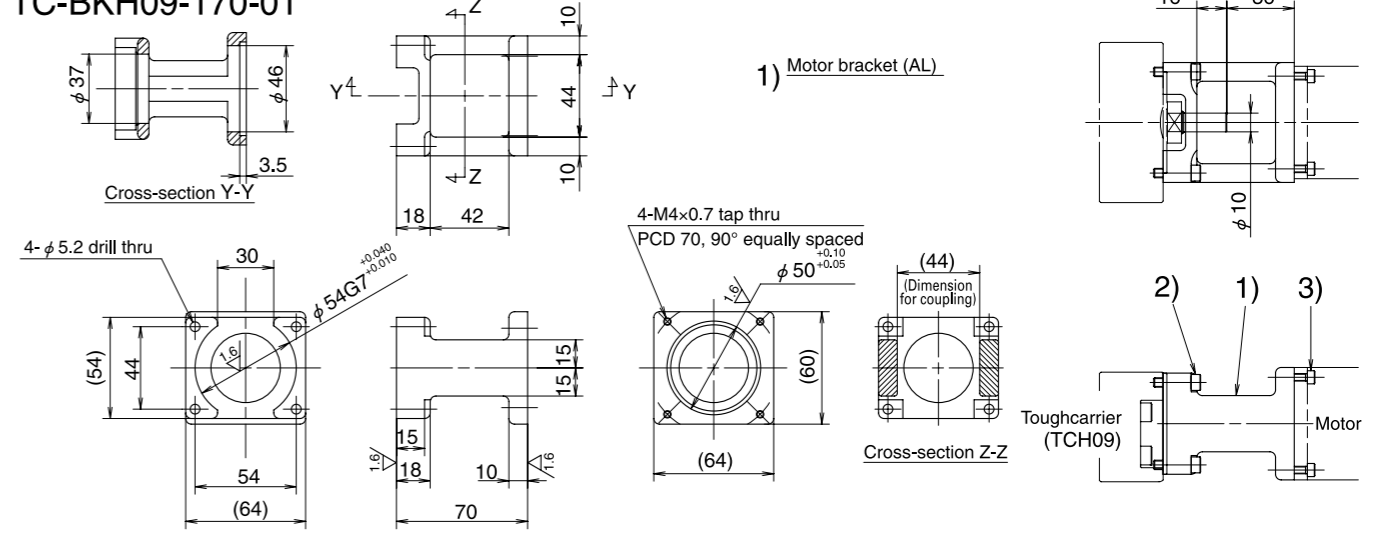

- 1) Motor bracket (AL)
- 2) Hexagon socket head cap screw (M5, length 20)
- 3) Hexagon socket head cap screw (M4, length 14)

Notes: 1. Be sure to align the center lines when installing the motor.
2. Be careful of the assembly orientation of the bracket.
3. As the bracket is made by sand casting, the external dimensions are for reference only.

Applicable motors	
Manufacturer	Motor model
Panasonic Co., Ltd.	MSMD02(200W), MAMA02(200W), MSMD04(400W), MAMA04(400W)

Reference number
TC-BKH09-170-00

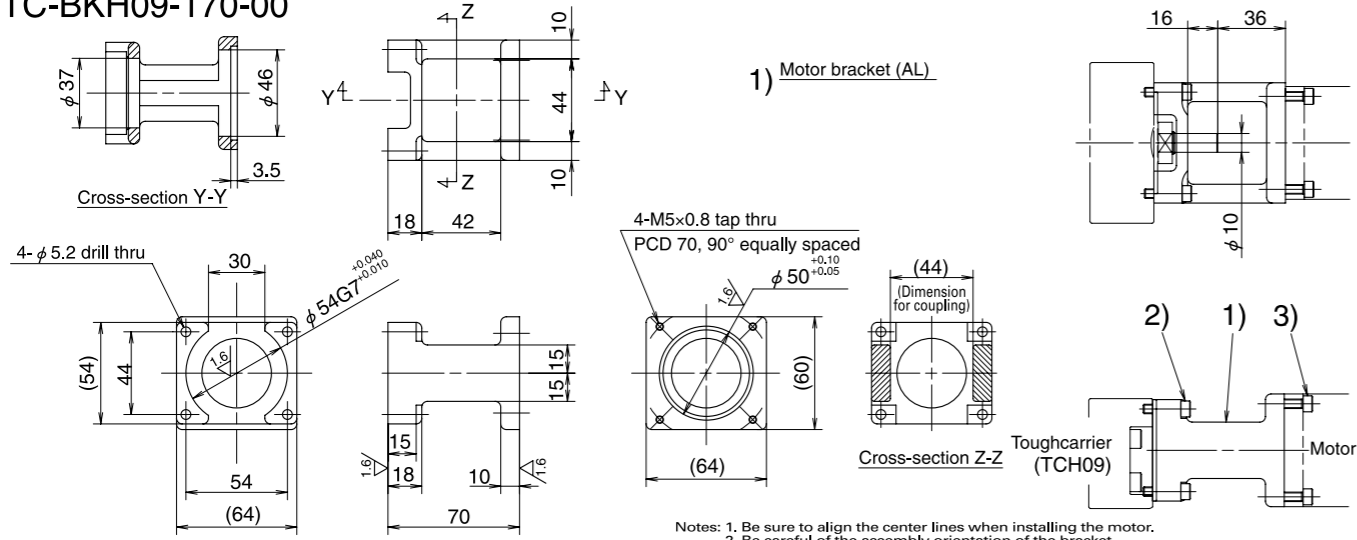

- 1) Motor bracket (AL)
- 2) Hexagon socket head cap screw (M5, length 20)
- 3) Hexagon socket head cap screw (M5, length 14)

Notes: 1. Be sure to align the center lines when installing the motor.
2. Be careful of the assembly orientation of the bracket.
3. As the bracket is made by sand casting, the external dimensions are for reference only.

Applicable motors	
Manufacturer	Motor model
YASKAWA Electric Corp.	SGMJV-02A(200W), SGMJV-04A(400W), SGMJV-04A(400W), SGMJV-04A(400W)
Mitsubishi Electric Corp.	HF-KP23(200W), HF-MP23(200W), HF-KP43(400W), HF-MP43(400W), HC-KFS23(200W), HC-MFS23(200W), HC-KFS43(400W), HC-MFS43(400W)
OMRON Corp.	R88M-VW20(200W), R88M-VW40(400W)
SANYO DENKI Co., Ltd.	P50B06020(200W), P30B06040(400W), R2AA06010(100W), R2AA06020(200W), R2A06040(400W)

Reference number
TC-BKH09-190-00

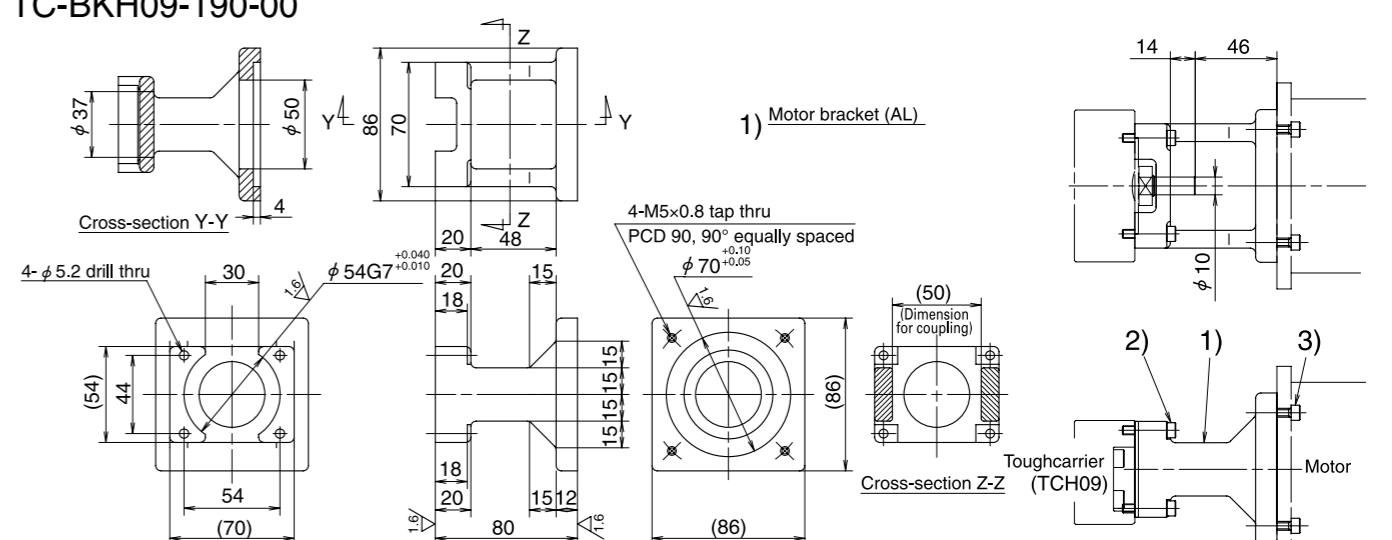

- 1) Motor bracket (AL)
- 2) Hexagon socket head cap screw (M5, length 25)
- 3) Hexagon socket head cap screw (M5, length 16)

Notes: 1. Be sure to align the center lines when installing the motor.
2. Be careful of the assembly orientation of the bracket.
3. As the bracket is made by sand casting, the external dimensions are for reference only.

Applicable motors	
Manufacturer	Motor model
SANYO DENKI Co., Ltd.	P50B07020(200W), P50B07030(300W), P50B07040(400W)

2-7 Motor Bracket Compatibility Table

Reference number
TC-BKH10-190-00

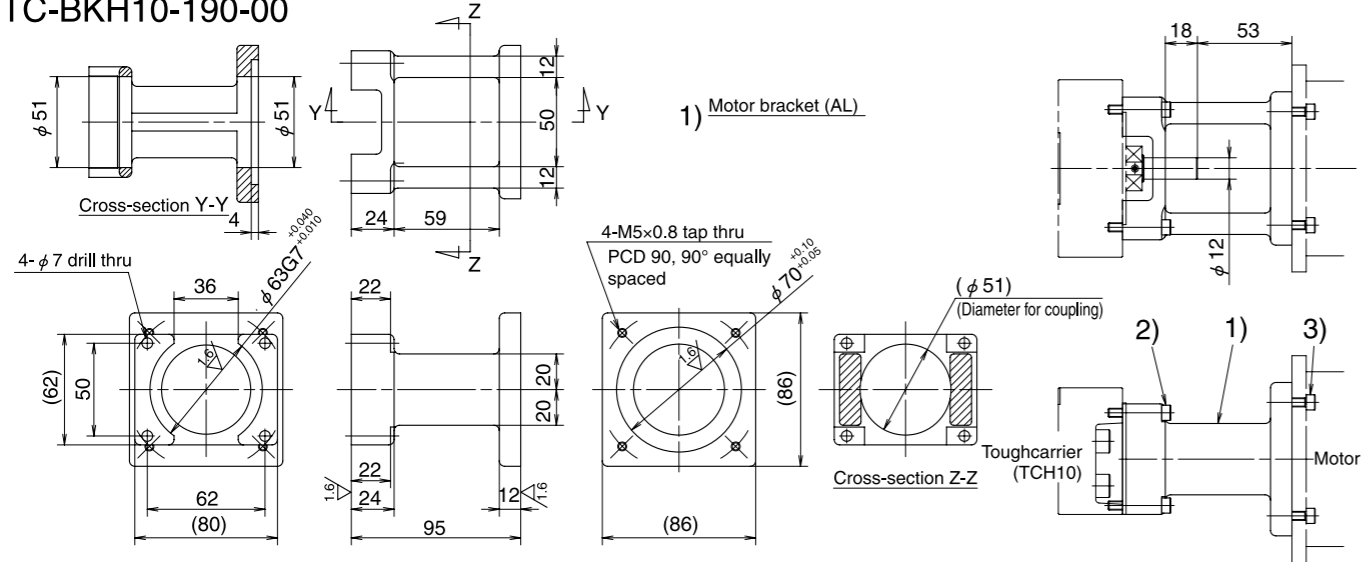

2) Hexagon socket head cap screw (M6, length 30)

3) Hexagon socket head cap screw (M5, length 16)

Notes: 1. Be sure to align the center lines when installing the motor.
2. Be careful of the assembly orientation of the bracket.
3. As the bracket is made by sand casting, the external dimensions are for reference only.

Applicable motors	
Manufacturer	Motor model
Panasonic Co., Ltd.	MSMD08(750W), MAMA08(750W)
SANYO DENKI Co., Ltd.	P50B07020(200W), P50B07030(300W), P50B07040(400W)

Reference number
TC-BKH10-270-00

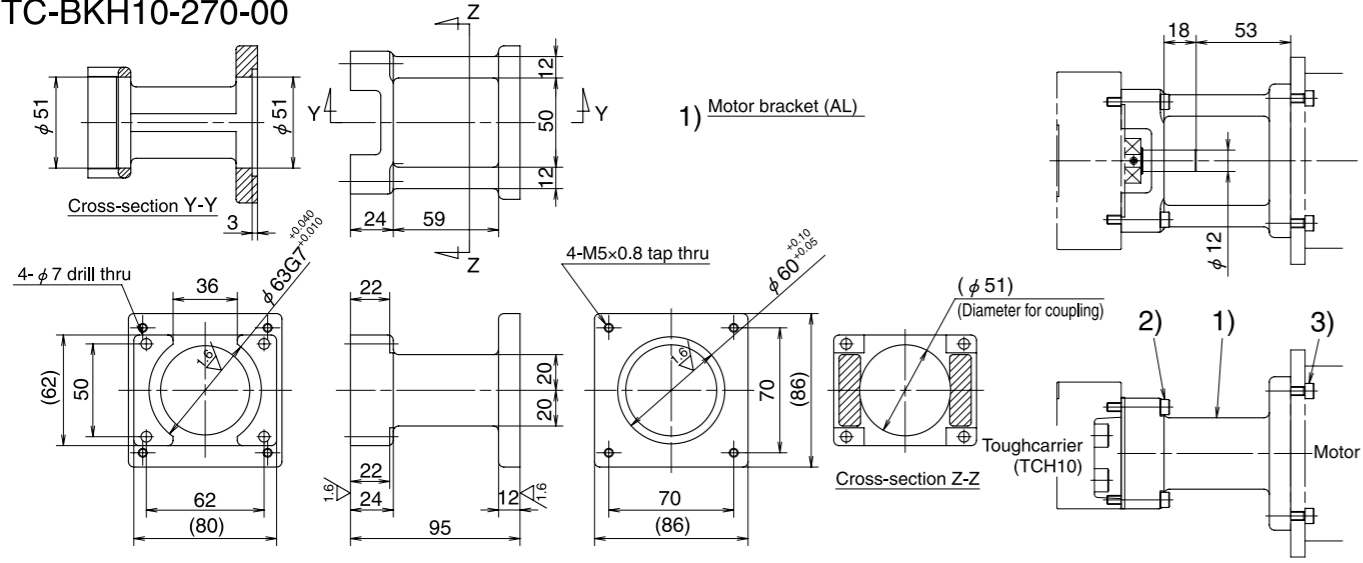

2) Hexagon socket head cap screw (M6, length 30)

3) Hexagon socket head cap screw (M5, length 16)

Notes: 1. Be sure to align the center lines when installing the motor.
2. Be careful of the assembly orientation of the bracket.
3. As the bracket is made by sand casting, the external dimensions are for reference only.

Applicable motors	
Manufacturer	Motor model
SANYO DENKI Co., Ltd.	103FB5XX
ORIENTAL MOTOR Co., Ltd.	AS98, UPK59X, PK59X, CSK59X, CFK59X, UFK59X

Model No.	Reference number	Motor manufacturer	Stepping motor model no.	Wattage of AC servo motor										
				30W	50W	60W	100W	150W	200W	300W	400W	750W		
TCH06	TC-BKH06-145-00	Panasonic Co., Ltd.			MSMD5A		MSMD10							
	TC-BKH06-146-00	YASKAWA Electric Corp.			SGMJV-A5A SGMAV-A5A		SGMJV-01A SGMAV-01A		SGMJV-C2A SGMAV-C2A					
		Mitsubishi Electric Corp.			HF-KP053 HF-MP053 HC-KFS053 HC-MFS053		HF-KP13 HF-MP13 HC-KFS13 HC-MFS13							
		OMRON Corp.		R88M-W03	R88M-W05		R88M-W10							
		SANYO DENKI Co., Ltd.		P30B04003	P30B04005 R2AA04005		P30B04010 R2AA04010							
	TC-BKH06-148-00	Panasonic Co., Ltd.					MAMA01							
	TC-BKH06-160-00	SANYO DENKI Co., Ltd.				P50B05005	P50B04006	P50B04010		P50B05010	P50B05020			
	TC-BKH06-250-00	SANYO DENKI Co., Ltd.	PBM603XXX PBM604XXX 103F78XX											
		ORIENTAL MOTOR Co., Ltd.	AS66 ASC66 UPK56X PK56X CSK56X CFK56X UFK56X											
	TCH09	TC-BKH09-145-00	Panasonic Co., Ltd.					MSMD01						
TC-BKH09-146-00		YASKAWA Electric Corp.					SGMJV-01A SGMAV-01A		SGMJV-C2A SGMAV-C2A					
		Mitsubishi Electric Corp.					HF-KP13 HF-MP13 HC-KFS13 HC-MFS13							
		SANYO DENKI Co., Ltd.				P30B04005		P30B04010 R2AA04010						
TC-BKH09-160-00		SANYO DENKI Co., Ltd.				P50B05005		P50B05010		P50B05020				
TC-BKH09-170-00		YASKAWA Electric Corp.							SGMJV-02A SGMAV-02A		SGMJV-04A SGMAV-04A			
		Mitsubishi Electric Corp.							HF-KP23 HF-MP23 HC-KFS23 HC-MFS23		HF-KP43 HF-MP43 HC-KFS43 HC-MFS43			
		OMRON Corp.					R88M-W20		R88M-W40					
		SANYO DENKI Co., Ltd.						P30B06020 R2AA06020		P30B06040 R2AA06040				
TC-BKH09-170-01		Panasonic Co., Ltd.												
TC-BKH09-190-00	SANYO DENKI Co., Ltd.							P50B07020	P50B07030	P50B07040				
TC-BKH09-250-00	SANYO DENKI Co., Ltd.	PBM603XXX PBM604XXX 103F78XX												
	ORIENTAL MOTOR Co., Ltd.	AS66 ASC66 UPK56X PK56X CSK56X CFK56X UFK56X												
	ORIENTAL MOTOR Co., Ltd.	AS98 UPK59X PK59X CSK59X CFK59X UFK59X												
TC-BKH09-270-00	ORIENTAL MOTOR Co., Ltd.	103FB5XX												
TCH10	TC-BKH10-170-00	YASKAWA Electric Corp.								SGMJV-02A SGMAV-02A		SGMJV-04A SGMAV-04A		
		Mitsubishi Electric Corp.								HF-KP23 HF-MP23 HC-KFS23 HC-MFS23		HF-KP43 HF-MP43 HC-KFS43 HC-MFS43		
		OMRON Corp.								R88M-W20		R88M-W40		
		SANYO DENKI Co., Ltd.								P30B06020 R2AA06020		P30B06040 R2AA06040		
	TC-BKH10-170-01	Panasonic Co., Ltd.												
TC-BKH10-190-00	Panasonic Co., Ltd.												MSMD08 MAMA08	
	SANYO DENKI Co., Ltd.								P50B07020	P50B07030	P50B07040			
TC-BKH10-270-00	ORIENTAL MOTOR Co., Ltd.	103FB5XX												

2-8 Sensor Rail and Top Cover Unit Combination Table

Model No.	Reference number	Rail length (L _r)	Sensor rail reference number	Cover unit reference number
TCH06	TCH06005H05K00	150	TC-SRL6-0150	TC-HV06005K00
	TCH06005H10K00			
	TCH06005H20K00			
	TCH06007H05A00			
	TCH06007H10A00			
	TCH06010H05K00	200	TC-SRL6-0200	TC-HV06010K00
	TCH06010H10K00			
	TCH06010H20K00			
	TCH06012H05A00			
	TCH06012H10A00			
	TCH06020H05K00	300	TC-SRL6-0300	TC-HV06020K00
	TCH06020H10K00			
	TCH06020H20K00			
	TCH06013H05D00			
	TCH06013H10D00			
	TCH06022H05A00			
	TCH06022H10A00			
	TCH06017H05B00			
	TCH06017H10B00			
	TCH06030H05K00			
	TCH06030H10K00			
	TCH06030H20K00			
	TCH06023H05D00			
	TCH06023H10D00			
	TCH06032H05A00			
	TCH06032H10A00			
	TCH06027H05B00			
	TCH06027H10B00			
	TCH06040H05K00	500	TC-SRL6-0500	TC-HV06040K00
	TCH06040H10K00			
TCH06040H20K00				
TCH06033H05D00				
TCH06033H10D00				
TCH06042H05A00				
TCH06042H10A00				
TCH06037H05B00				
TCH06037H10B00				
TCH06050H05K00	600			
TCH06050H10K00				
TCH06050H20K00				
TCH06043H10D00				
TCH06043H20D00				
TCH06052H05A00				
TCH06052H10A00				
TCH06047H10B00				

• Sensor rail reference numbers are determined according to the rail length. Select a sensor rail appropriate for your requirements.

• Shapes and numbers of spacer plates for cover unit are selected according to slider specifications.

Model No.	Reference number	Rail length (L _r)	Sensor rail reference number	Cover unit reference number		
TCH09	TCH09010H05K00	240	TC-SRL9-0240	TC-HV09010K00		
	TCH09010H10K00					
	TCH09010H20K00					
	TCH09014H05A00					
	TCH09014H10A00					
	TCH09014H20A00	340	TC-SRL9-0340	TC-HV09020K00		
	TCH09020H05K00					
	TCH09020H10K00					
	TCH09024H05A00					
	TCH09024H10A00					
	TCH09024H20A00	440	TC-SRL9-0440	TC-HV09030K00		
	TCH09030H05K00					
	TCH09030H10K00					
	TCH09030H20K00					
	TCH09017H05D00					
	TCH09017H10D00					
	TCH09034H05A00					
	TCH09034H10A00					
	TCH09034H20A00					
	TCH09025H05B00					
	TCH09025H10B00					
	TCH09040H05K00					
	TCH09040H10K00					
	TCH09040H20K00					
	TCH09027H05D00				540	TC-SRL9-0540
	TCH09027H10D00					
	TCH09044H05A00					
	TCH09044H10A00					
	TCH09044H20A00					
	TCH09035H05B00					
	TCH09035H10B00					
	TCH09050H05K00					
	TCH09050H10K00					
	TCH09050H20K00	640	TC-SRL9-0640	TC-HV09050K00		
	TCH09037H05D00					
	TCH09037H10D00					
	TCH09054H05A00					
	TCH09054H10A00					
	TCH09054H20A00					
	TCH09045H05B00					
TCH09045H10B00						
TCH09060H05K00						
TCH09060H10K00	740				TC-SRL9-0740	TC-HV09060K00
TCH09060H20K00						
TCH09047H10D00						
TCH09047H20D00						
TCH09064H05A00						
TCH09064H10A00						
TCH09064H20A00						
TCH09055H10B00						
TCH09055H20B00						
TCH09070H05K00		840	TC-SRL9-0840	TC-HV09070K00		
TCH09070H10K00						
TCH09070H20K00						
TCH09074H05A00						
TCH09074H10A00						
TCH09074H20A00						
TCH09080H05K00						
TCH09080H10K00						
TCH09080H20K00	940				TC-SRL9-0940	TC-HV09080K00
TCH09067H10D00						
TCH09067H20D00						
TCH09084H05A00						
TCH09084H10A00						
TCH09084H20A00						
TCH09075H10B00						
TCH09075H20B00						

• Sensor rail reference numbers are determined according to the rail length. Select a sensor rail appropriate for your requirements.

• Shapes and numbers of spacer plates for cover unit are selected according to slider specifications.

Model No.	Reference number	Rail length (L _r)	Sensor rail reference number	Cover unit reference number
TCH10	TCH10010H10K00	280	TC-SRL1-0280	TC-HV10010K00
	TCH10010H20K00			TC-HV10016A00
	TCH10016H10A00			
	TCH10016H20A00	380	TC-SRL1-0380	TC-HV10020K00
	TCH10020H10K00			TC-HV10026A00
	TCH10020H20K00			
	TCH10026H10A00	480	TC-SRL1-0480	TC-HV10030K00
	TCH10026H20A00			TC-HV10036A00
	TCH10030H10K00			
	TCH10030H20K00	580	TC-SRL1-0580	TC-HV10040K00
	TCH10036H10A00			TC-HV10027D00
	TCH10036H10A00			TC-HV10046A00
	TCH10040H10K00			TC-HV10036B00
	TCH10040H20K00			
	TCH10027H10D00			
	TCH10027H20D00	680	TC-SRL1-0680	TC-HV10050K00
	TCH10046H10A00			TC-HV10037D00
	TCH10046H20A00			TC-HV10056A00
	TCH10036H10B00			TC-HV10046B00
	TCH10036H20B00			
	TCH10050H10K00			
	TCH10050H20K00	780	TC-SRL1-0780	TC-HV10060K00
	TCH10037H10D00			TC-HV10047D00
	TCH10037H20D00			TC-HV10066A00
	TCH10056H10A00			TC-HV10056B00
	TCH10056H20A00			
	TCH10046H10B00			
	TCH10046H20B00	880	TC-SRL1-0880	TC-HV10070K00
	TCH10060H10K00			TC-HV10057D00
	TCH10060H20K00			TC-HV10076A00
	TCH10047H10D00			TC-HV10066B00
	TCH10047H20D00			
	TCH10066H10A00			
	TCH10066H20A00	980	TC-SRL1-0980	TC-HV10080K00
	TCH10056H10B00			TC-HV10067D00
	TCH10056H20B00			TC-HV10086A00
	TCH10070H10K00			TC-HV10076B00
	TCH10070H20K00			
	TCH10057H10D00			
	TCH10057H20D00	1 080	TC-SRL1-1080	TC-HV10090K00
	TCH10076H10A00			TC-HV10077D00
	TCH10076H20A00			TC-HV10096A00
	TCH10066H10B00			TC-HV10086B00
	TCH10066H20B00			
	TCH10080H10K00			
	TCH10080H20K00	1 180	TC-SRL1-1180	TC-HV10100K00
	TCH10067H10D00			TC-HV10087D00
	TCH10067H20D00			TC-HV10106A00
	TCH10086H10A00			TC-HV10096B00
	TCH10086H20A00			
	TCH10076H10B00			
	TCH10076H20B00	1 280	TC-SRL1-1280	TC-HV10110K00
	TCH10090H10K00			TC-HV10097D00
	TCH10090H20K00			TC-HV10116A00
TCH10077H20D00	TC-HV10106B00			
TCH10096H10A00				
TCH10096H20A00				
TCH10086H20B00	1 380	TC-SRL1-1380	TC-HV10120K00	
TCH10100H10K00			TC-HV10107D00	
TCH10100H20K00			TC-HV10126A00	
TCH10087H20D00			TC-HV10116B00	
TCH10106H10A00				
TCH10106H20A00				
TCH10096H20B00				
TCH10110H10K00				
TCH10110H20K00				
TCH10097H20D00				
TCH10116H10A00				
TCH10116H20A00				
TCH10106H20B00				
TCH10120H10K00				
TCH10120H20K00				
TCH10107H20D00				
TCH10126H10A00				
TCH10126H20A00				
TCH10116H20B00				

• Sensor rail reference numbers are determined according to the rail length. Select a sensor rail appropriate for your requirements.
 • Shapes and numbers of spacer plates for cover unit are selected according to slider specifications.

2-9 Toughcarrier High-Thrust Series (Special product)

◆ Specifications

The life of the feeding system is improved by use of higher load capacity ball screw part and support bearings for standard Toughcarrier.

		TCH06		TCH09		TCH10	
Ball screw	Shaft diameter (mm)	12		20		25	
	Lead (mm)	10	20	10	20	20	25
	Basic dynamic load rating Ca (N)	3 760	2 970	11 500	8 790	9 760	9 760
	Basic static load rating Coa (N)	6 310	4 240	25 700	18 500	23 600	23 600
Linear guide	Basic dynamic load rating C (N)	20 900		44 900		62 400	
	Basic static load rating Co (N)	45 000		96 900		132 000	
Support bearings	Basic dynamic load rating (N)	5 900		18 800		21 900	
	Load limit (N)	3 500		11 500		26 600	

- 1) Only compatible with standard slider.
- 2) Applicable strokes are as follows.
 TCH06: Stroke 500 mm
 TCH09: Stroke 800 mm
 TCH10: Stroke 1 200 mm
- 3) High and precision grades are available for accuracy

◆ Features

- 1) Mounting dimensions are the same as Monocarrier MCH Series and standard Toughcarrier. (Interchangeable)
- 2) Permissible rotational speed is faster than standard Toughcarrier due to different ball recirculation system.

3 Technical Materials

3-1. Sensor Specification	135
3-1.1 Proximity Switch	135
3-1.2 Photo Sensor	136
3-2. Characteristics and Evaluation Method	137
3-2.1 Positioning Accuracy	137
3-2.2 Repeatability	137
3-2.3 Running Parallelism	137
3-3. Special Specifications	138
3-4. Maintenance	139
3-4.1 Maintenance Method	139
3-4.2 NSK K1™ Lubricant Unit	139
3-5. NSK Clean Grease LG2 Specification	140

3-1 Sensor Specification

3-1. 1 Proximity Switch

Use of OMRON E2S-W13 and E2S-W14

Item	E2S-W13 type	E2S-W14 type
Setting surface	Front face	
Sensing distance	1.6 mm ±15%	
Setting distance	0 to 1.2 mm	
Differential travel	10% max. of sensing distance	
Detectable object type	Ferrous metal	
Standard sensing object	Iron, 12 × 12 × 1 mm	
Response frequency	1 kHz min.	
Power supply voltage (operating voltage range)	12 to 24 VDC; ripple (p-p), 10% max (10 to 30 VDC)	
Current consumption	13 mA max. at 24 VDC with no load	
Control output (Switching Capacity)	NPN open collector output, 50 mA max. (30 VDC max.)	
Control output (Residual voltage)	1.0 V max. with a load current of 50 mA and a cable length of 1 m	
Indicator	Operation indicator (orange)	
Operating status (with sensing object approaching)	NO (Normally open contact)	NC (Normally close contact)
Wire lead length	1 000 mm	

Notes: 1. Do not make a wrong connection.
2. Please contact NSK for PNP output type.

Movement mode	Output type	Type	Time chart	Output circuit
NO	NPN	E2S-W13 type		<p>*(Maximum load current: 50 mA)</p>
		E2S-W14 type		
NC	NPN	E2S-W14 type		

E2S-W13 (Normally open contact)
E2S-W14 (Normally close contact)
The external appearances are the same.

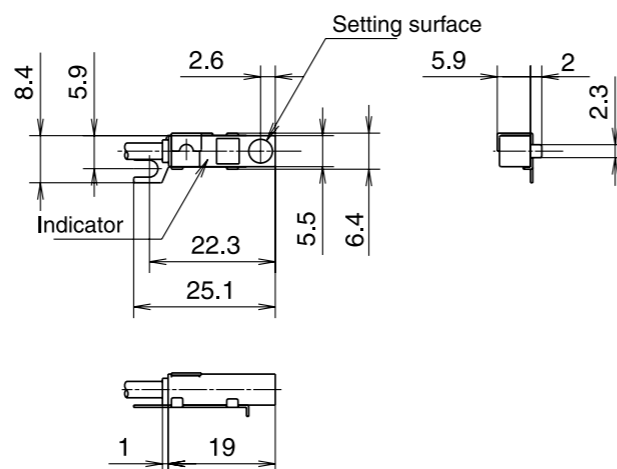

3-1. 2 Photo Sensor

Use of OMRON EE-SX674

Item	EE-SX674 type
Slot width	5 mm
Standard reference object	Opaque, 2 × 0.8 mm
Differential distance	0.025 mm
Light source	GaAs infrared LED with peak wavelength of 940 nm
Indicator (without detecting object)	ON GaP red LED (peak emission wavelength, 690 nm)
Supply voltage	5 to 24 VDC ±10%; ripple (p-p), 10% max.
Current consumption	35 mA max.
Control output	NPN open collector output models, 5 to 24 VDC, 100 mA load current
Response frequency	1 kHz max. (3 kHz typ.)
Ambient illumination	Fluorescent light, 1 000 lx max.
Ambient temperature	-25°C to 55°C (-13°F to 131°F) (for operating); -30°C to 80°C (-22°F to 176°F) (for storing)
Ambient humidity	5 to 85% RH (for operating); 5 to 95% RH (for storing)
Connecting method	EE-1001/1006 Connectors, soldering terminals

Notes: 1. Do not make a wrong connection.
2. Please contact NSK for PNP output type.

Type	Movement mode	Time chart	Connection terminal	Output circuit
EE-SX674 type	Light-ON		When terminals L and ⊕ are short circuited	
	Dark-ON		When terminals L and ⊕ are open circuited	

EE-SX674 (Sensor)
EE-1001 (Connector)

A connector is mounted to the sensor in the right figure.

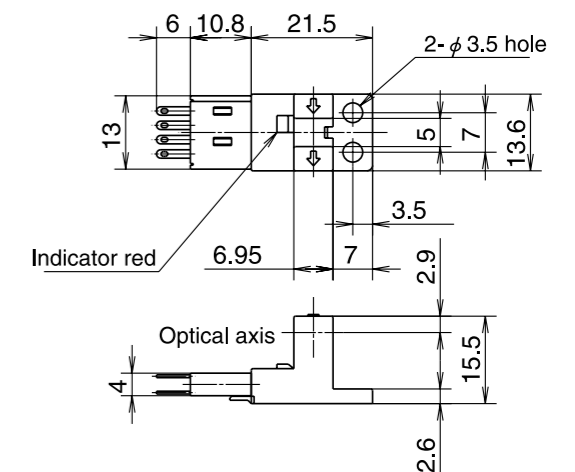

3-2 Characteristics and Evaluation Method

3-2.1 Positioning Accuracy

Perform successive positioning from the reference position in a specific direction. Measure the difference between the actual and desired travel distances for each point from the reference position. Repeat this measurement seven times to determine the average value. Measure such average value over the entire travel distance at the intervals specified for each model and take the maximum difference of the average values determined at respective positions as the measured value.

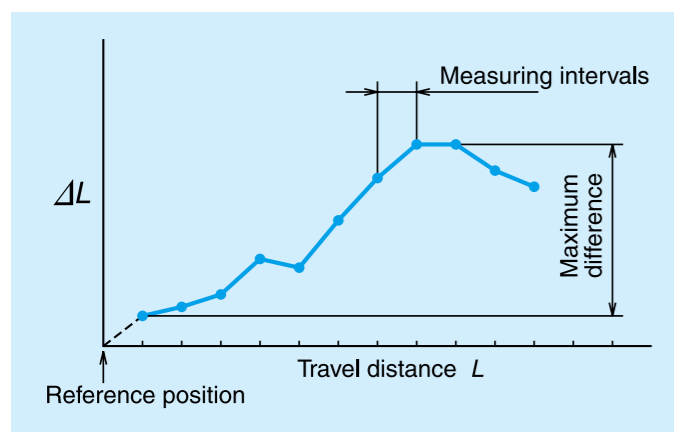

Fig. 1

3-2.3 Running Parallelism (Vertical direction)

We specify the parallelism of slider to the datum bottom surface of rail. An indicator is moved in the axial slider making its stylus slightly touching on the rail bottom surface. The slider is moved in the axial direction for the checking. We define the total indicator reading as the running parallelism. During the checking, the rail is not fixed to the table base. Please be aware that, in general application, the rail is fixed to the machine base, and thus the wobbly rolling error will be added to the running parallelism.

3-2.2 Repeatability

Repeat positioning at any point seven times from the same direction to measure the stopping position and determine one half of the maximum difference of readings. Repeat this measurement over the entire travel distance at the intervals specified for each model. Take the maximum difference of the determined values as the measured value. Express one half of the maximum difference with a plus-or-minus (\pm) sign.

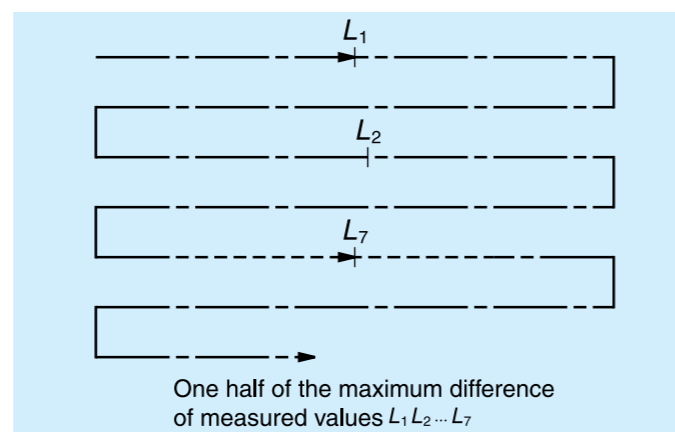

Fig. 2

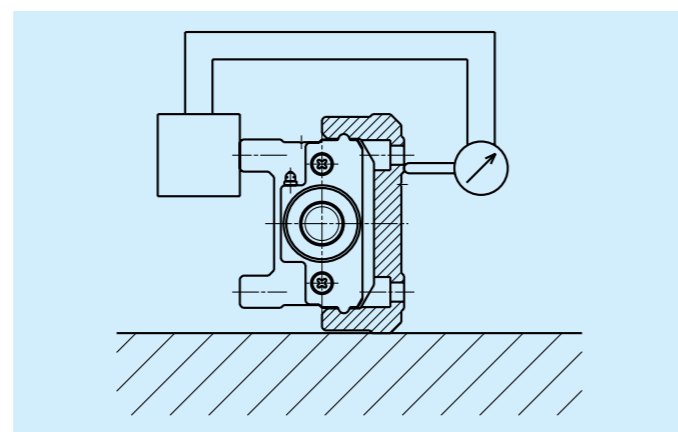

Fig. 3 Setting of indicator

3-3 Special Specifications

Please consult NSK if your requirement is not in the standard products.

(1) Surface Treatment

- Fluoride low temperature chrome plating
- Note: Ball screw parts (including low temperature chrome plating.)

(2) Special Machining (Processing)

- Shaft end processing
 - Key way processing
 - One flat or two flats processing

- Pin hole processing

- Slider
- Rail

Note: Due to interference with the internal construction, the position of pin hole is limited. Please consult with NSK about the pin position.

(3) Motor Bracket and Intermediate Plate for Motor Mounting

- We provide motor mounting brackets and intermediate plates that are not listed in the catalog.
- We assemble motor upon request if the motor is provided in advance.

Note: Motion check of the motor is unavailable.

(4) Reversed Motor Mount

The reversed motor mount is available. Please consult NSK.

- Notes: 1) We do not check motor running condition.
2) Please refer to the bottom of page 87 to 89 for the configuration of reversed motor mounting of the MCH series.

(5) Right and Left Turn Thread

Right and left turn ball screw is available. Please consult with NSK for available leads.

(6) Ball-Screw-Less Specification (Only Linear Guide Part)

A ball-screw-less rail part with the same cross section of standard Monocarriers is available for a driven linear guide. It will lessen a height adjustment work compared with a construction with two standard Monocarriers. Note: Height grinding adjustment of the two axes assembly is not available.

3-4 Maintenance

3-4.1 Maintenance Method

1. For standard Monocarrier, we pack grease in the slider, linear guides and ball screw.
2. Monocarriers are equipped with NSK K1 Lubrication Unit as a standard feature, therefore, you may use it for 5 years or 10 000 km depending on your application, whichever comes first, without maintenance. However, replenishment of preceded grease may extend its life substantially.
3. The NSK K1 Lubrication Unit is ideal in environments where oily dust exists. However, the life may be shorter than described in Clause 2 above. In such a case, it requires increasing the frequency of replenishment.

4. A Nozzle for the NSK grease pump for MCH Monocarriers is available as an option.
NSK reference number: NSK HGP NZ8

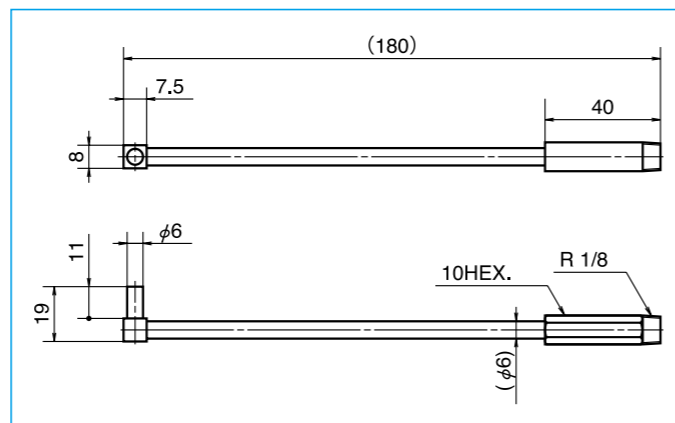

Fig. 4 NSK HGP NZ8

Precautions for handling

1. Please consult with NSK when the motor is coupled to the ball screw using a pulley because there is a restriction on allowable load to the end of ball screw shaft.
2. To extend high performance of NSK K1 lubrication unit, please observe the following.

1. Temperature range Ambient temperature: 50°C
 Max. instantaneous temperature: 80°C
2. Use of chemicals Never leave a Monocarrier in close proximity of grease removing organic solvents such as hexane or thinner. Never immerse it in an antirust solvent that contains kerosene.

Note: Other oils, such as water-based and oil based cutting oil, and grease do not cause any problems.

3-4. 2 NSK K1™ Lubricant Unit

NSK K1 lubrication unit exhibits outstanding features, confirmed by abundant experimental data, along with proven performance of linear guides and ball screws that are equipped with NSK K1.

(1) High-Speed Durability Test of Linear Guides without Lubricant

Results of high-speed durability testing of a linear guide without lubricant are shown in Fig. 5 While the linear guide cannot be operated without lubricant for even short periods without damage, the installation of the NSK K1 permits the linear guide to run over 25 000 km without any problem.

Conditions	Test piece: LH30AN (Preload Z1)
	Speed: 3.3 m/s
	Stroke: 1 800 mm
No lubricant	All grease removed
NSK K1	All grease removed + NSK K1

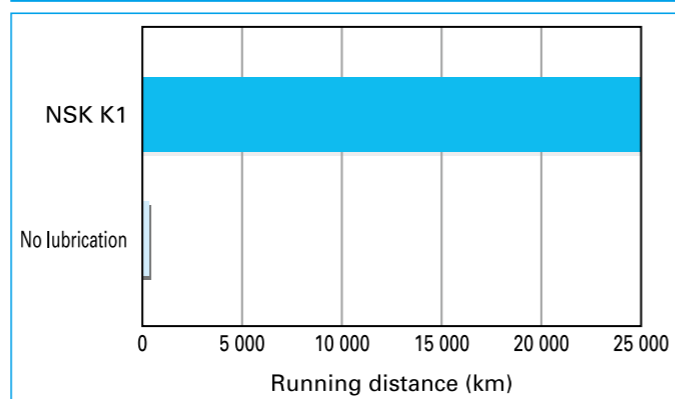

Fig. 5 Results of high-speed durability test of linear guides without lubricant

(2) High-Speed Durability Test of Ball Screws without Lubricant

Results of high-speed durability testing of ball screw without lubrication are shown in Fig. 6 While the ball screw cannot be operated without a lubricant at 8.5 km without damage, the installation of the NSK K1 permits the ball screw to run over 21 000 km without any problem.

Conditions	Test piece: BS2020 (Ball screw)
	Shaft diameter: 20 mm
	Lead: 20 mm
	Load: none
	Speed: 1.3 m/s (4 000 min ⁻¹)
No lubricant	All grease removed
	NSK K1

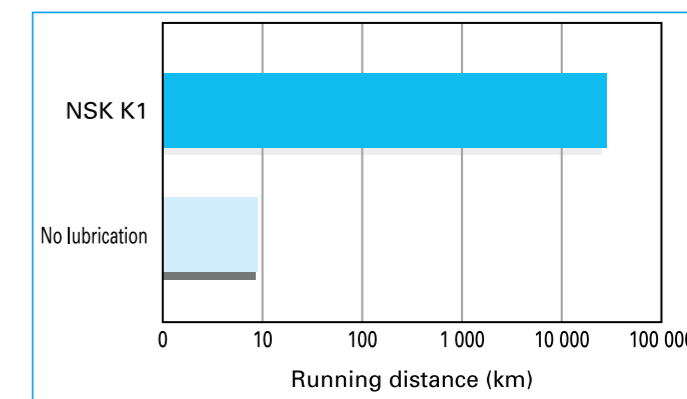

Fig. 6 Results of high-speed durability test of ball screws without lubricant

● NSK K1 Lubrication Units for food processing and medical devices are available.

For safety equipment of food processing and medical care, NSK provides the Monocarrier equipped with special NSK K1 Lubrication Unit that is made of materials approved by the FDA. Dimensions are the same as the standard NSK K1 Lubrication Unit, and special handling care is not required.

3-5 NSK Clean Grease LG2 Specification

● Features

This grease was developed by NSK to be exclusively used for linear guides and ball screws in clean rooms. Compared to the fluoride grease which are commonly used in clean rooms, LG2 has several advantages such as: higher in lubrication function, longer lubrication life, more stable torque (resistant to wear), and higher rust prevention. In dust generation, LG2 is more than equal to fluoride grease in keeping dust volume low. Since the base oil is not a special oil but a mineral oil, LG2 can be handled in the same manner as general grease.

● Applications

LG2 is lubrication grease for rolling contact machine components such as linear guides and ball screws for processing equipment for semiconductors and LCD which require highly clean environment at normal pressure in normal temperatures. It cannot be used in a vacuum environment.

● Nature

Thickener	Lithium soap base
Base oil	Mineral oil + Synthetic hydrocarbon oil
Consistency	199
Dropping point	201°C
Volume of evaporation	1.40% (99°C, 22 hr)
Copper plate corrosion test	Satisfactory (Method B, 100°C, 24 hr)
Oil separation	0.8% (100°C, 24 hr)
Base oil Kinematic Viscosity	32 mm ² /s (40°C)

Worldwide Sales Offices

P: Phone F: Fax ☆: Head Office

NSK LTD.-HEADQUARTERS, TOKYO, JAPAN

Nissei Bldg., 1-6-3 Ohsaki, Shinagawa-ku, Tokyo 141-8560, Japan
INDUSTRIAL MACHINERY BUSINESS DIVISION-HEADQUARTERS
P: +81-3-3779-7227 F: +81-3-3779-7644
AUTOMOTIVE BUSINESS DIVISION-HEADQUARTERS
P: +81-3-3779-7189 F: +81-3-3779-7917

●Africa

South Africa:

NSK SOUTH AFRICA (PTY) LTD.

SANDTON 27 Galaxy Avenue, Linbro Business Park, Sandton 2146, South Africa
P: +27-11-458-3600 F: +27-11-458-3608

●Asia and Oceania

Australia:

NSK AUSTRALIA PTY. LTD.

MELBOURNE ☆ 11 Dalmore Drive, Scoresby, Victoria 3179, Australia
P: +61-3-9765-4400 F: +61-3-9764-8304
SYDNEY Unit 10, 24-28 River Road West, Parramatta, New South Wales, 2150, Australia
P: +61-2-8843-8100 F: +61-2-9893-8406
BRISBANE 1/69 Selhurst Street, Coopers Plains, Queensland 4108, Australia
P: +61-7-3347-2600 F: +61-7-3345-5376
PERTH Unit 1, 71 Tacoma Circuit, Canning Vale, Western Australia 6155, Australia
P: +61-8-9256-5000 F: +61-8-9256-1044

New Zealand:

NSK NEW ZEALAND LTD.

AUCKLAND 3 Te Apunga Place, Mt. Wellington, Auckland 1060, New Zealand
P: +64-9-276-4992 F: +64-9-276-4082

China:

NSK (SHANGHAI) TRADING CO., LTD.

JIANGSU No.8 NSK Rd., Huaqiao Economic Development Zone, Kunshan, Jiangsu, China (215332)
P: +86-512-5796-3000 F: +86-512-5796-3300

NSK (CHINA) INVESTMENT CO., LTD.

JIANGSU ☆ No.8 NSK Rd., Huaqiao Economic Development Zone, Kunshan, Jiangsu, China (215332)
P: +86-512-5796-3000 F: +86-512-5796-3300

BEIJING Room 2116, Beijing Fortune Bldg., 5 Dong San Huan Bei Lu, Chao Yang District, Beijing, China (100004)
P: +86-10-6590-8161 F: +86-10-6590-8166

TIAN JIN Room 06, 09F The Exchange Tower 2, No. 189 NanJing Road, Heping District, Tianjin, China (300050)
P: +86-22-8319-5030 F: +86-22-8319-5033

CHANGCHUN Room 2311, Building A, Zhongyin Building, 727 Xi'an Road, Changchun, Jilin, China (130061)
P: +86-431-8898-8682 F: +86-431-8898-8670

SHENYANG Room 1101, China Resources Building, No. 286 Qingnian Street, Heping District, Shenyang Liaoning, China (110004)
P: +86-24-2334-2868 F: +86-24-2334-2058

DALIAN Room 1805 Xiwang Tower, No.136 Zhongshan Road, Zhongshan District, Dalian, Liaoning, China (116001)
P: +86-411-8800-8168 F: +86-411-8800-8160

NANJING Room A1 22F, Golden Eagle International Plaza, No.89 Hanzhong Road, Nanjing, Jiangsu, China (210029)
P: +86-25-8472-6671 F: +86-25-8472-6687

FUZHOU Room 1801-1811, B1#1A Class Office Building, Wanda Plaza, No.8 Aojiang Road, Fuzhou, China (350009)
P: +86-591-8380-1030 F: +86-591-8380-1225

WUHAN Room 1110, New World International Trade Tower I, No.568 Jianshe Road, Wuhan, Hubei, China (430000)
P: +86-27-8556-9630 F: +86-27-8556-9615

QINGDAO Room 802, Farglory International Plaza, No.26 Xianggang Zhong Road, Shinan District, Qingdao, Shandong, China (266071)
P: +86-532-5568-3877 F: +86-532-5568-3876

GUANGZHOU Room 2302, TaiKoo Hui Tower 1, No.385 Tianhe Road, Tianhe District, Guangzhou, China (510620)
P: +86-20-3817-7800 F: +86-20-3786-4501

CHANGSHA Room 1048, 10/F, Zhongtian Plaza, No.766 WuyiRoad, Changsha, Hunan, China (410005)
P: +86-731-8571-3100 F: +86-731-8571-3255

LUOYANG Room 1108, Fangda Hotel, 6 XiYuan Road, LuoYang HeNan, China (471003)
P: +86-379-6069-6188 F: +86-379-6069-6180

XI'AN Room 1007, B Changan Metropolis Center 88 Nanguanzheng Steet, Xi'an, Shanxi, China (710068)
P: +86-29-8765-1896 F: +86-29-8765-1895

CHONGQING Room 2306, Unit B, No.137, Keyuan 2nd Road, Jiulongpo District, Chongqing, China (400039)
P: +86-23-6806-5310 F: +86-23-6806-5292

CHENGDU Room 1117, Lippo Tower, No.62 North Kehua Road, Chengdu, Sichuan, China (610041)
P: +86-28-8528-3680 F: +86-28-8528-3690

NSK CHINA SALES CO., LTD.

JIANGSU No.8 NSK Rd., Huaqiao Economic Development Zone, Kunshan, Jiangsu, China (215332)
P: +86-512-5796-3000 F: +86-512-5796-3300

NSK HONG KONG LTD.

HONG KONG ☆ Suite 705, 7th Floor, South Tower, World Finance Centre, Harbour City, T.S.T, Kowloon, Hong Kong, China
P: +852-2739-9933 F: +852-2739-9323

SHENZHEN Room 624-626, 6/F, Kerry Center, Renminnan Road, Shenzhen, Guangdong, China
P: +86-755-25904886 F: +86-755-25904883

Taiwan:

TAIWAN NSK PRECISION CO., LTD.

TAIPEI ☆ 11F., No.87, Song Jiang Rd., Jhongsan District, Taipei City 104, Taiwan R.O.C.
P: +886-2-2509-3305 F: +886-2-2509-1393

TAICHUNG 3F., -2, No. 540, Sec. 3, Taiwan Blvd., Xitun Dist., Taichung City 407, Taiwan R.O.C.
P: +886-4-2708-3393 F: +886-4-2708-3395

TAINAN 5F, No.8, Daye 1st Rd., Southern Taiwan Science Park, Tainan City 741, Taiwan R.O.C.
P: +886-6-505-5861 F: +886-6-505-5061

TAIWAN NSK TECHNOLOGY CO., LTD.

TAIPEI ☆ 11F., No.87, Song Jiang Rd., Jhongsan District, Taipei City 104, Taiwan R.O.C.
P: +886-2-2509-3305 F: +886-2-2509-1393

TAICHUNG 10F-3, No.925, Sec.4, Taiwan Blvd., Xitun Dist., Taichung City 407, Taiwan R.O.C.
P: +886-4-2358-2945 F: +886-4-2358-7682

TAINAN 5F, No.8, Daye 1st Rd., Southern Taiwan Science Park, Tainan City 741, Taiwan R.O.C.
P: +886-6-505-5861 F: +886-6-505-5061

India:

NSK INDIA SALES CO.PVT.LTD.

CHENNAI ☆ 6th Floor, Bannari Amman Towers, No.29 Dr. Radhakrishnan Salai, Mylapore, Chennai-600 004 Tamil Nadu, India
P: +91-44-2847-9600 F: +91-44-2847-9601

GURGAON Unit No-202, 2nd Floor, Block-A, Iris Tech Park, Sector-48, Sohna Road, Gurgaon-122018, Haryana, India
P: +91-124-4104-530 F: +91-124-4104-532

MUMBAI 321, 'A' Wing, Ahura Centre, 82, Mahakali Caves Road, Andheri (East), Mumbai -400 093, India
P: +91-22-2838-7787 F: +91-22-2838-5191

Indonesia:

PT. NSK INDONESIA

JAKARTA Summitas II, 6th Floor, Jl. Jend Sudirman Kav. 61-62, Jakarta 12190, Indonesia
P: +62-21-252-3458 F: +62-21-252-3223

Korea:

NSK KOREA CO., LTD.

SEOUL Posco Center (West Wing) 9F, 440, Teheran-ro, Gangnam-gu, Seoul, 135-777, Korea
P: +82-2-3287-0300 F: +82-2-3287-0345

Malaysia:

NSK BEARINGS (MALAYSIA) SDN. BHD.

SHAH ALAM ☆ No. 2, Jalan Pemaju, U1/15, Seksyen U1, Hicom Glenmarie Industrial Park, 40150 Shah Alam, Selangor, Malaysia
P: +60-3-7803-8859 F: +60-3-7806-5982

PRAI No.24, Jalan kikik, Taman Inderawasih, 13600 Prai, Penang, Malaysia
P: +60-4-3902275 F: +60-4-3991830

JOHOR BAHRU 88 Jalan Ros Merah 2/17, Taman Johor Jaya, 81100 Johor Bahru, Johor, Malaysia
P: +60-7-3546290 F: +60-7-3546291

IPOH Gr. Floor, 89 Jalan Bendahara, 31650 Ipoh, Perak, Malaysia
P: +60-5-2555000 F: +60-5-2553373

Philippines:

NSK REPRESENTATIVE OFFICE

MANILA 8th Floor The Salcedo Towers 169 H.V. dela Costa St., Salcedo Village Makati City, Philippines 1227
P: +63-2-893-9543 F: +63-2-893-9173

Singapore:

NSK INTERNATIONAL (SINGAPORE) PTE LTD.

SINGAPORE 238A, Thomson Road, #24-01/05, Novena Square Tower A, Singapore 307684
P: +65-6496-8000 F: +65-6250-5845

NSK SINGAPORE (PRIVATE) LTD.

SINGAPORE 238A, Thomson Road, #24-01/05, Novena Square Tower A, Singapore 307684
P: +65-6496-8000 F: +65-6250-5845

Thailand:

NSK BEARINGS (THAILAND) CO.,LTD.

BANGKOK 26 Soi Onnuch 55/1 Pravet Subdistrict, Pravet District, Bangkok 10250, Thailand
P: +66-2320-2555 F: +66-2320-2826

Vietnam:

NSK VIETNAM CO., LTD.

HANOI Techno Center, Room 204-205, Thang Long Industrial Park, Dong Anh District, Hanoi, Vietnam
P: +84-4-3955-0159 F: +84-4-3955-0158

NSK REPRESENTATIVE OFFICE

HO CHI MINH CITY Suite 307, Metropolitan Building, 235 Dong Khoi Street, District 1, HCMC, Vietnam
P: +84-8-3822-7907 F: +84-8-3822-7910

Worldwide Sales Offices

P: Phone F: Fax ☆: Head Office

● Europe

United Kingdom:

NSK EUROPE LTD. (EUROPEAN HEADQUARTERS)

MAIDENHEAD Belmont Place, Belmont Road, Maidenhead, Berkshire SL6 6TB, U.K.
P: +44-1628-509-800 F: +44-1628-509-808

NSK UK LTD.

NEWARK Northern Road, Newark, Nottinghamshire NG24 2JF, U.K.
P: +44-1636-605-123 F: +44-1636-605-000

France:

NSK FRANCE S.A.S.

PARIS Quartier de l'Europe, 2 Rue Georges Guynemer, 78283 Guyancourt, France
P: +33-1-30-57-39-39 F: +33-1-30-57-00-01

Germany:

NSK DEUTSCHLAND GMBH

DUSSELDORF ☆ Harkortstrasse 15, D-40880 Ratingen, Germany
P: +49-2102-4810 F: +49-2102-4812-290

STUTTGART Liebknechtstrasse 33, D-70565 Stuttgart-Vaihingen, Germany
P: +49-711-79082-0 F: +49-711-79082-289

WOLFSBURG Tischlerstrasse 3, D-38440 Wolfsburg, Germany
P: +49-5361-27647-10 F: +49-5361-27647-70

Italy:

NSK ITALIA S.P.A.

MILANO Via Garibaldi 215, Garbagnate Milanese (Milano) 20024, Italy
P: +39-299-5191 F: +39-299-025778

Netherlands:

NSK EUROPEAN DISTRIBUTION CENTRE B.V.

TILBURG De Kroonstraat 38, 5048 AP Tilburg, Netherlands
P: +31-13-4647647 F: +31-13-4647648

Poland:

NSK REPRESENTATIVE OFFICE

WARSAW Ul. Migdalowa 4/73, 02-796, Warsaw, Poland
P: +48-22-645-1525 F: +48-22-645-1529

Russia:

NSK POLSKA SP. Z O.O.

SAINT-PETERSBURG Office 1703, Bldg 29, 18th Line of Vasilievskiy Ostrov, Saint-Petersburg, Russia, 199178
P: +7-812-332-5071 F: +7-812-332-5072

Spain:

NSK SPAIN S.A.

BARCELONA C/Tarragona, 161 Cuerpo Bajo, 2a Planta, 08014, Barcelona, Spain
P: +34-93-289-2763 F: +34-93-433-5776

Turkey:

NSK RULMANLARI ORTA DOGU TIC. LTD. STI.

ISTANBUL 19 Mayıs Mah. Atatürk Cad., Ulya Engin Is Merkezi No: 68 Kat. 6, P.K. : 34734,
Kozyatagi-Istanbul, Turkey
P: +90-216-477-7111 F: +90-216-477-7174

United Arab Emirates:

NSK BEARINGS GULF TRADING CO.

DUBAI JAFZA View 19, Floor 24 Office LB192402/3, PO Box 262163, DownTown Jebel Ali,
Dubai, UAE
P: +971-4-804-8207 F: +971-4-884-7227

● North and South America

United States of America:

NSK AMERICAS, INC. (AMERICAN HEADQUARTERS)

ANN ARBOR 4200 Goss Road, Ann Arbor, Michigan 48105, U.S.A.
P: +1-734-913-7500 F: +1-734-913-7511

NSK CORPORATION

ANN ARBOR 4200 Goss Road, Ann Arbor, Michigan 48105, U.S.A.
P: +1-734-913-7500 F: +1-734-913-7511

NSK PRECISION AMERICA, INC.

FRANKLIN ☆ 3450 Bearing Drive, Franklin, Indiana 46131, U.S.A.
P: +1-317-738-5000 F: +1-317-738-5050

SAN JOSE 780 Montague Expressway, Suite 504, San Jose, California, 95131, U.S.A.
P: +1-408-944-9400 F: +1-408-944-9405

NSK LATIN AMERICA, INC.

MIAMI 3470 NW 82 Avenue Suite 625, Miami FL 33122, U.S.A.
P: +1-305-477-0605 F: +1-305-477-0377

Canada:

NSK CANADA INC.

TORONTO ☆ 5585 McAdam Road, Mississauga, Ontario, Canada L4Z 1N4
P: +1-905-890-0740 F: +1-800-800-2788

MONTREAL 2150-32E Avenue Lachine, Quebec, Canada H8T 3H7
P: +1-514-633-1220 F: +1-800-800-2788

VANCOUVER 3353 Wayburne Drive, Burnaby, British Columbia, Canada V5G 4L4
P: +1-877-994-6675 F: +1-800-800-2788

Argentina:

NSK ARGENTINA SRL

BUENOS AIRES Garcia del Rio 2477 Piso 7 Oficina "A" (1429) Buenos Aires-Argentina
P: +54-11-4704-5100 F: +54-11-4704-0033

Brazil:

NSK BRASIL LTDA.

SAO PAULO ☆ Rua 13 de Maio, 1633-14th Andar-Bela Vista-CEP 01327-905 São Paulo, SP, Brazil
P: +55-11-3269-4786 F: +55-11-3269-4720

BELO HORIZONTE Rua Ceara 1431-4th andar-sala 405-Funcionarios Belo Horizonte-MG, Brazil
30150-311
P: +55-31-3274-2591 F: +55-31-3273-4408

JOINVILLE Rua Blumenau, 178-sala 910-Centro Joinville-SC, Brazil 89204-250
P: +55-47-3422-5445 F: +55-47-3422-2817

PORTO ALEGRE Av. Cristovão Colombo, 1694-sala 202-Floresta Porto Alegre-RS, Brazil 90560 001
P: +55-51-3222-1324 F: +55-51-3222-2599

RECIFE Av. Conselheiro Aguiar, 2738-6th andar-conj. 604-Boa Viagem Recife-PE, Brazil 51020-020
P: +55-81-3326-3781 F: +55-81-3326-5047

Peru:

NSK PERU S.A.C.

LIMA Av. Caminos del Inca 670, Ofic : # 402, Santiago del Surco, Lima, Perú
P: +51-1-652-3372 F: +51-1-638-0555

Mexico:

NSK RODAMIENTOS MEXICANA, S.A. DE C.V.

MEXICO CITY ☆ Av. Presidente Juarez No.2007 Lote 5, Col. San Jeronimo Tepetlaco,
Tlalnepantla, Estado de Mexico, Mexico, C.P.54090
P: +52-55-3682-2900 F: +52-55-3682-2937

MONTERREY Av. Ricardo Margain 575, IOS Torre C, Suite 516, Parque Corporativo Santa
Engracia, San Pedro Garza Garcia, N.L. Mexico, C.P.66267
P: +52-81-8000-7300 F: +52-81-8000-7095

<As of January 2015>

For the latest information, please refer to the NSK website.

www.nsk.com

NSK Ltd. has a basic policy not to export any products or technology designated as controlled items by export-related laws. When exporting the products in this brochure, the laws of the exporting country must be observed. Specifications are subject to change without notice and without any obligation on the part of the manufacturer. Every care has been taken to ensure the accuracy of the data contained in this brochure, but no liability can be accepted for any loss or damage suffered through errors or omissions. We will gratefully acknowledge any additions or corrections.

