

Linear Way F

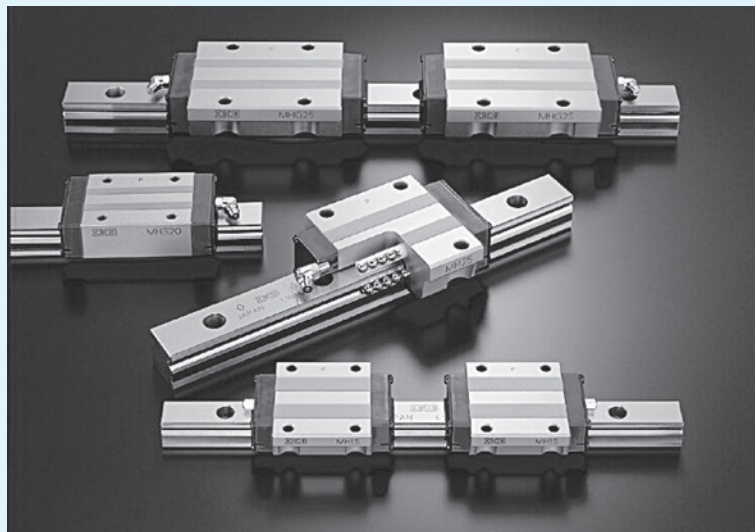

Linear Way F

LWFF

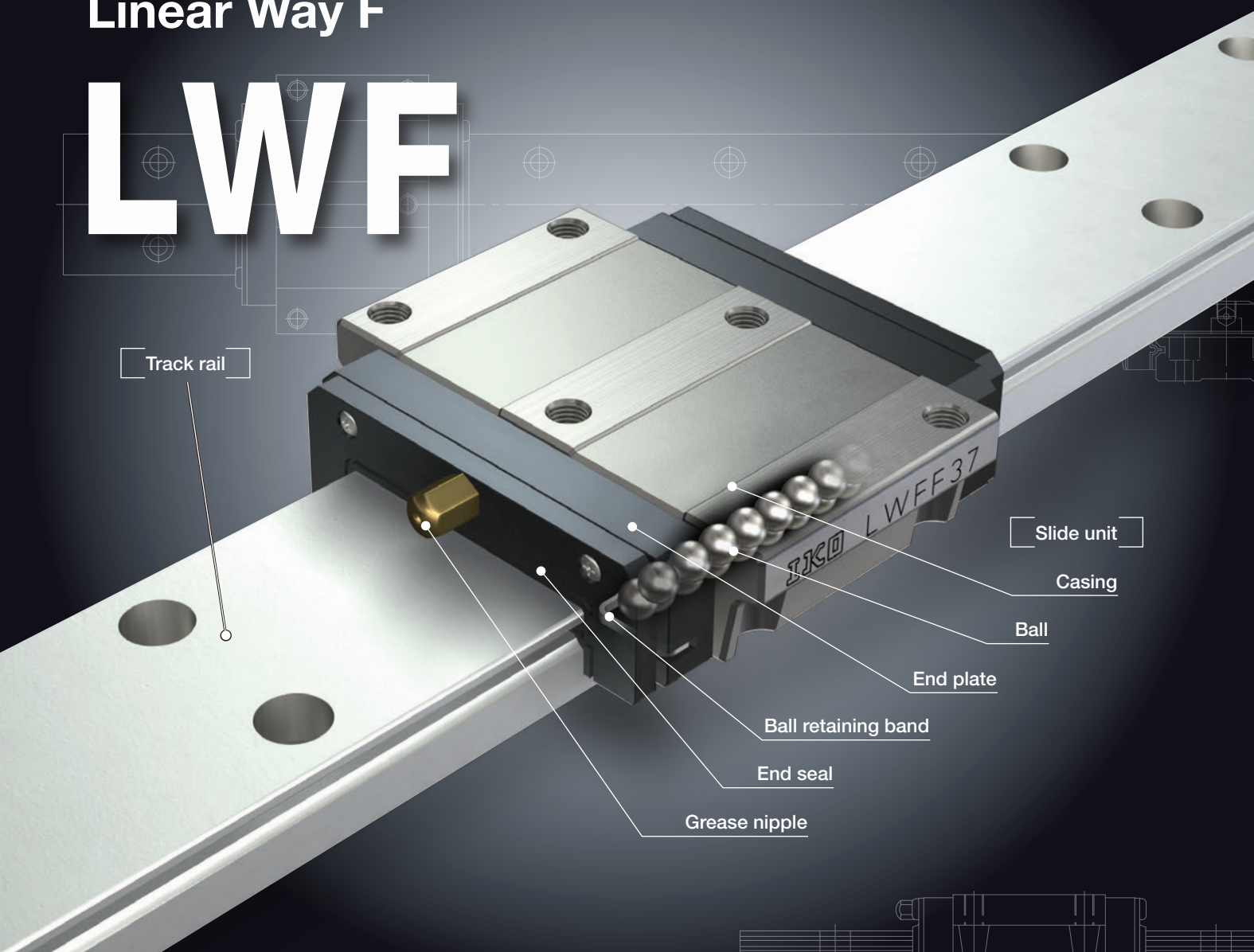

Points

● Wide rail type series resistant to moment load

As track rail width is wide and distance between moment load points is long, this is a linear motion rolling guide resistant to moment load and complex load and suitable for serial use.

● Slide unit shapes for various usage

As the lineup of three types of slide unit shape including two flange types with different dimensional series and block type with small width are available, you can select an optimal product for the specifications of your machine and device.

● Stainless steel selections superior in corrosion resistance are listed on lineup. For details ▶ P.I-41

Products made of stainless steel are highly resistant to corrosion, so that they are suitable for applications where rust prevention oil is not preferred, such as in a cleanroom environment.

Identification Number and Specification

Example of an identification number

The specification of LWFF series is indicated by the identification number. Indicate the identification number, consisting of a model code, dimensions, a part code, a material code, a preload symbol, a classification symbol, an interchangeable code, and any supplemental codes for each specification to apply.

	1	2	3	4	5	6	7	8	9
Non-interchangeable specification									
Assembled set	LWFF	37	C1	R800		T ₁	P		/FZ
Interchangeable specification									
Single slide unit	LWFF	37	C1			T ₁	P	S1	/Z
Single track rail ⁽¹⁾	LWFF	37		R800			P	S1	/F
Assembled set	LWFF	37	C1	R800		T ₁	P	S1	/FZ

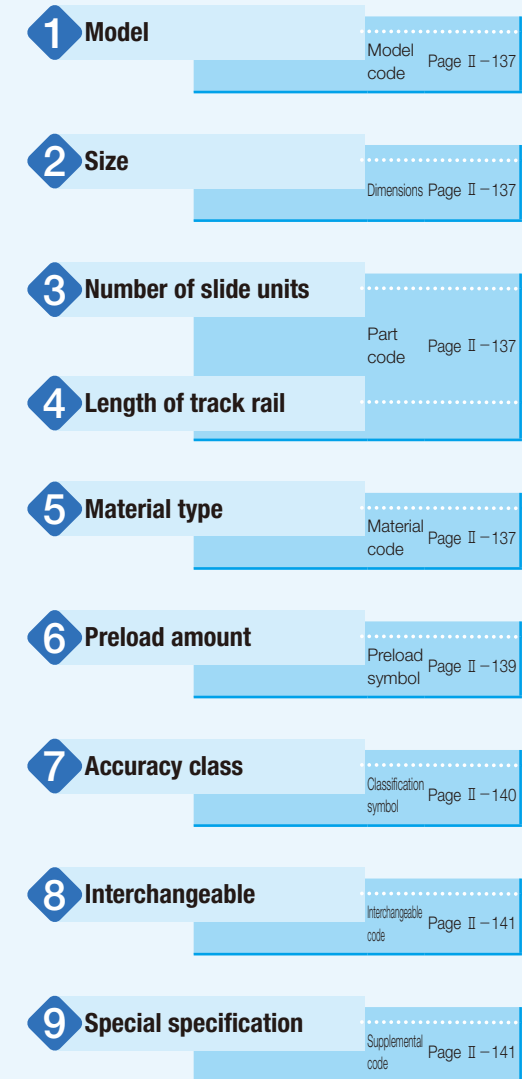

Note (1) Indicate "LWFF" for the model code of the single track rail of block type LWFS mounting from top.

Identification Number and Specification — Model · Size · Number of Slide Unit ·

1 Model	Linear Way F ⁽¹⁾ (LWF series)	Flange type mounting from top / bottom	: LWFH : LWFF
		Block type mounting from top	: LWFS
For applicable models and sizes, see Table 1. Indicate "LWFF" for the model code of the single track rail of block type LWFS mounting from top. Note ⁽¹⁾ This model has no built-in C-Lube.			
2 Size	33,37,40,42,60,69,90	For applicable models and sizes, see Table 1.	
3 Number of slide units	: C○	For an assembled set, indicates the number of slide units assembled on a track rail. For a single slide unit, only "C1" is specified.	
4 Length of track rail	: R○	Indicate the length of track rail in mm. For standard and maximum length, see Table 2.1 and Table 2.2.	
5 Material type	High carbon steel made	: No symbol	For applicable models and sizes, see Table 1.
	Stainless steel made ⁽²⁾	: SL	
Note ⁽²⁾ Mount a standard grease nipple (brass) on the stainless steel type, too. Stainless steel grease nipple is also available. If needed, please contact IKO .			

Table 1 Models and sizes of LWF series

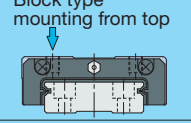
Material	Shape	Model	Size						
			33	37	40	42	60	69	90
High carbon steel made	Flange type mounting from top/bottom 	LWFH	—	—	○	—	○	—	○
	Flange type mounting from top/bottom 	LWFF	○	○	—	○	—	○	—
	Block type mounting from top 	LWFS	○	○	—	—	—	—	—
Stainless steel made	Block type mounting from top 	LWFS...SL	○	○	—	○	—	—	—

Remark: For the models indicated in , the interchangeable specification is available.

Length of Track Rail · Material Type—

Table 2.1 Standard and maximum length of high carbon steel track rail

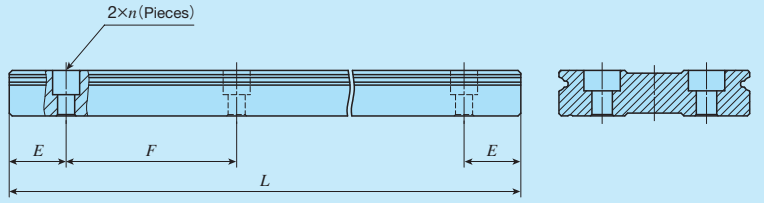

Item	LWFH40	LWFH60	LWFH90
Standard length L (n)	180 (3)	240 (3)	480 (6)
	240 (4)	480 (5)	640 (8)
	360 (6)	640 (8)	800 (10)
	480 (8)	800 (10)	1 040 (13)
	660 (11)	1 040 (13)	1 200 (15)
	840 (14)		1 520 (19)
Pitch of mounting holes F	60	80	80
E	30	40	40
Standard E dimensions ⁽¹⁾	or higher	8	10
	below	38	50
Maximum length ⁽²⁾	1 500	1 520	1 520

unit: mm

Item	LWFF33 LWFS33	LWFF37 LWFS37	LWFF42	LWFF69
Standard length L (n)	120 (3)	150 (3)	180 (3)	320 (4)
	200 (5)	250 (5)	240 (4)	480 (6)
	320 (8)	400 (8)	360 (6)	800 (10)
	480 (12)	500 (10)	480 (8)	1 040 (13)
	560 (14)	600 (12)	660 (11)	1 280 (16)
		800 (16)	840 (14)	1 600 (20)
Pitch of mounting holes F	40	50	60	80
E	20	25	30	40
Standard E dimensions ⁽¹⁾	or higher	7	7	9
	below	27	32	49
Maximum length ⁽²⁾	1 600	2 000	1 980	2 000

Notes ⁽¹⁾ This does not apply to female threads for bellows (supplemental code "/J").

⁽²⁾ We can produce products longer than the maximum length. If needed, please contact **IKO**.

Remarks 1. Indicate "LWFF" for the model code of the single track rail of block type LWFS mounting from top.

2. If not directed, E dimensions for both ends will be the same within the range of standard E dimensions. To change the dimensions, indicate the specified rail mounting hole positions "/E" of special specification. For more information, see page III-30.

Table 2.2 Standard and maximum length of stainless steel track rail

Item	LWFS33...SL	LWFS37...SL	LWFS42...SL
Standard length L (n)	120 (3)	150 (3)	180 (3)
	200 (5)	250 (5)	240 (4)
	320 (8)	400 (8)	360 (6)
	480 (12)	500 (10)	480 (8)
	560 (14)	600 (12)	660 (11)
		800 (16)	840 (14)
Pitch of mounting holes F	40	50	60
E	20	25	30
Standard E dimensions ⁽¹⁾	or higher	7	7
	below	27	32
Maximum length ⁽²⁾	1 200	1 200	1 200

Notes ⁽¹⁾ This does not apply to female threads for bellows (supplemental code "/J").

⁽²⁾ We can produce products longer than the maximum length. If needed, please contact **IKO**.

Remarks 1. Indicate "LWFF" for the model code of the single track rail.

2. If not directed, E dimensions for both ends will be the same within the range of standard E dimensions. To change the dimensions, indicate the specified rail mounting hole positions "/E" of special specification. For more information, see page III-30.

—Preload Amount—

6	Preload amount	Standard	: No symbol	Specify this item for an assembled set or a single slide unit.
	Light preload	: T ₁	For details of the preload amount, see Table 3.	
	Medium preload	: T ₂	For applicable preload types, see Table 4.	

Table 3 Preload amount

Preload type	Item	Preload symbol	Preload amount N	Operational conditions
Standard	(No symbol)	0 ⁽¹⁾	· Light and precise motion	
Light preload	T ₁	0.02C ₀	· Almost no vibrations · Load is evenly balanced · Light and precise motion	
Medium preload	T ₂	0.05C ₀	· Medium vibration · Medium overhung load	

Note ⁽¹⁾ Indicates zero or minimal amount of preload.
Remark: C₀ indicates the basic static load rating.

Table 4 Application of preload

Size	Preload type (preload symbol)		
	Standard (No symbol)	Light preload (T ₁)	Medium preload (T ₂)
33	○	○	○
37	○	○	○
40	○	○	○
42	○	○	○
60	○	○	○
69	○	○	○
90	○	○	○

Remark: The mark indicates that interchangeable specification products are available.

—Accuracy Class—

7	Accuracy class	High	: H	For interchangeable specification products, assemble a slide unit and a track rail of the same accuracy class.
	Precision	: P	For details of accuracy class, see Table 5.	
	Super precision	: SP	For applicable accuracy class, see Table 6.	

Table 5 Tolerance and allowance

unit: mm

Item	Class (classification symbol)		
	High (H)	Precision (P)	Super precision (SP)
Dim. H tolerance	±0.040	±0.020	±0.010
Dim. N tolerance	±0.050	±0.025	±0.015
Dim. variation of H ⁽¹⁾	0.015	0.007	0.005
Dim. variation of N ⁽¹⁾	0.020	0.010	0.007
Dim. variation of H for multiple assembled sets ⁽²⁾	0.035	0.025	—
Parallelism in operation of the slide unit C surface to A surface	See Fig. 1		
Parallelism in operation of the slide unit D surface to B surface	See Fig. 1		

Notes ⁽¹⁾ It means the size variation between slide units mounted on the same track rail.
⁽²⁾ Applicable to the interchangeable specifications.

Table 6 Application of accuracy class

Size	Class (classification symbol)		
	High (H)	Precision (P)	Super precision (SP)
33	○	○	○
37	○	○	○
40	○	○	○
42	○	○	○
60	○	○	○
69	○	○	○
90	○	○	○

Remark: The mark indicates that interchangeable specification products are available.

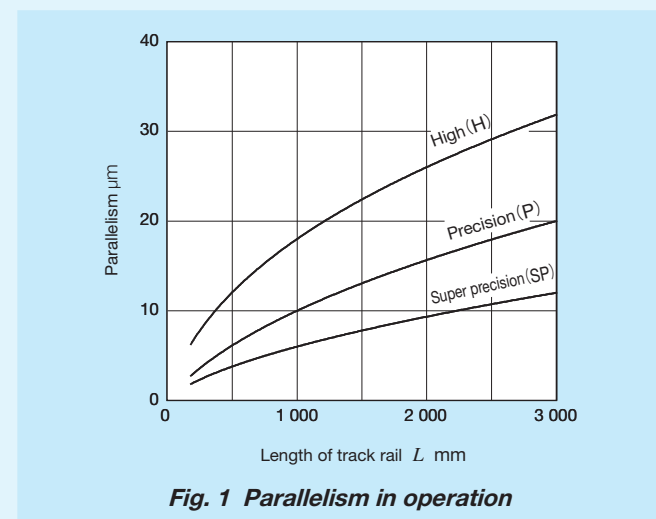

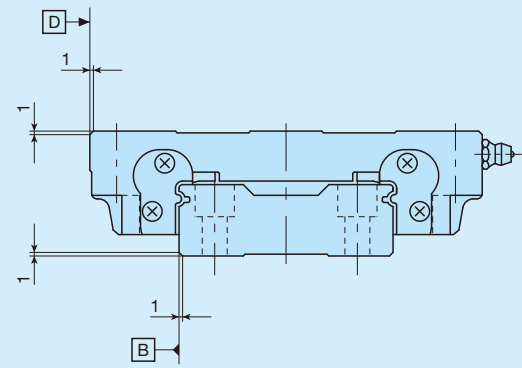
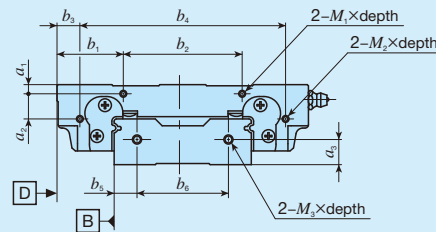

Fig. 2 Dimension of chamfered reference surface (Supplemental code /C /CC)

Remark: Add chamfer to the reference mounting surface of the slide unit and track rail.
For corner R of the mounting section, see Table 17.2 on page II - 148.

Table 9 Dimension of female threads for bellows (Supplemental code Single unit: /J Assembled set: /J /JJ)



unit: mm

Identification number	Slide unit								Track rail			
	a_1	a_2	b_1	b_2	b_3	b_4	$M_1 \times \text{depth}$	$M_2 \times \text{depth}$	a_3	b_5	b_6	$M_3 \times \text{depth}$
LWFH 40	3	—	23.5	35	—	—	M3×6	—	9	8	24	M3×6
LWFH 60	4	11	29	52	10	90	M3×6	M3×3	11	10	40	M4×8
LWFH 90	6	17	41	80	13	136	M3×5	M3×5	13	15	60	M4×8

Table 10 Dimension of female threads for bellows (Supplemental code Single unit: /J Assembled set: /J /JJ)

Size 33, 37

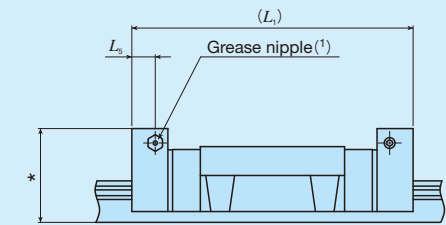
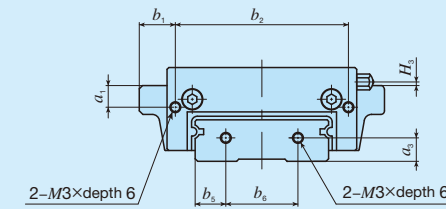

Size 42

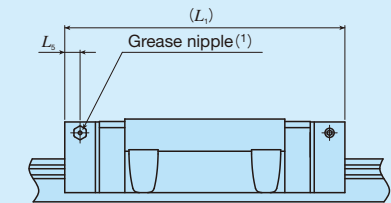
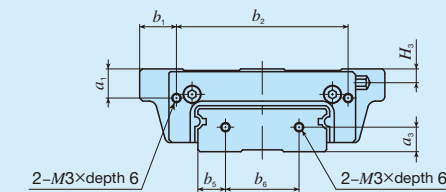

Size 69

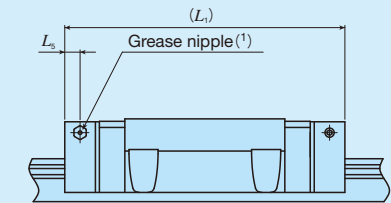
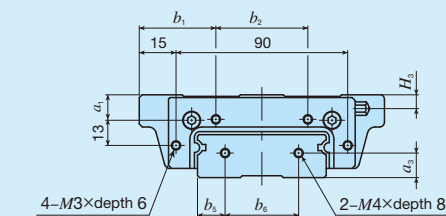

unit: mm

Identification number	Slide unit						Track rail			
	a_1	b_1	b_2	$L_1^{(2)}$	L_2	H_3	a_3	b_5	b_6	
LWFF 33	4	8.25	43.5	71	5	1	6	7.5	18	
LWFS 33(...SL)		3.25								
LWFF 37	6	10	48	78	5	1	6.5	8.5	20	
LWFS 37(...SL)		3								
LWFF 42	9.5	12	56	92	7	4.5	8	9	24	
LWFS 42...SL		3								
LWFF 69	9	35	50	125	7	5	11	14.5	40	

Notes (1) Grease nipple specifications and mounting position are different from standard specifications. Provided grease nipple is A-M3 for size 37 and 42 models, and A-M4 for size 69 model. For grease nipple specification, see Table 15 on page II - 146.

(2) Dimensions of the specification that female threads for bellows are fitted to both ends of the slide unit are indicated.

Remark: Dimensions indicated by * mark for series of size 33 and Size 37 is higher than the H dimension of Linear Way F. For details, contact **IKO**.

Table 11 Dimension of slide unit with C-Lube plate (Supplemental code /Q)

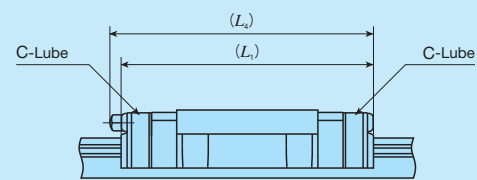

unit: mm

Size	L_1	L_4
33	64	66
37	73	75
40	78	—
42	86	98
60	98	—
69	121	132
90	131	—

Remark: The dimensions of the slide unit with C-Lube at both ends are indicated.

Table 12 H_1 dimension with under seal (Supplemental code /U)

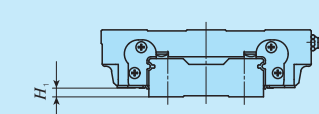

unit: mm

Size	H_1
40	3
60	4
90	5

Remark: H_1 dimensions of series of the Size 33, 37, 42, and 69 are the same as dimensions before mounting of under seal.

Table 13 Dimension of slide unit with double end seals (Supplemental code Single unit: /V Assembled set: /V /VV)

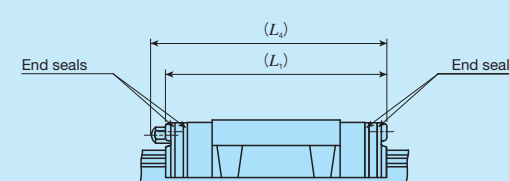

unit: mm

Size	L_1	L_4
33	61	64
37	70	74
42	82	96
69	117	130

Remark: The dimensions of the slide unit with double end seals at both ends are indicated.

Table 14 Dimension of slide unit with scrapers (Supplemental code Single unit: /Z Assembled set: /Z /ZZ)

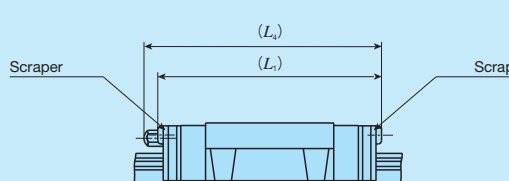

unit: mm

Size	L_1	L_4
33	62	64
37	71	75
40	80	—
42	84	97
60	100	—
69	119	131
90	130	—

Remark: The dimensions of the slide unit with scraper at both ends are indicated.

Lubrication

Lithium-soap base grease with extreme-pressure additive (Alvania EP grease 2 [SHOWA SHELL SEKIYU K. K.]) is pre-packed in LWF series.

LWF series has grease nipple as indicated in Table 15. Supply nozzles fit to each shapes of grease nipple are also available. For order of these parts for lubrication, see Table 14.1 on page III-23 and Table 15 on page III-24.

Table 15 Parts for lubrication

Size	Grease nipple type ⁽¹⁾	Applicable supply nozzle type	Bolt size of female threads for piping
33	A-M3	A-5120V A-5240V	—
37	A-M4	B-5120V B-5240V	M4
40	JIS type 1	Grease gun available on the market	M6
42	B-M6		
60	JIS type 1		
69	B-M6		
90	JIS type 1		

Note ⁽¹⁾ For grease nipple specification, see Table 14.1 and Table 14.2 on page III-23.

Remark: Stainless steel grease nipple is also available. If needed, please contact **IKO**.

Dust Protection

The slide units of LWF series are equipped with end seals as standard for dust protection. However, if large amount of contaminant or dust are floating, or if large particles of foreign substances such as chips or sand may adhere to the track rail, it is recommended to cover the whole unit with bellows or telescope type shield, etc.



LWF series is provided with specific bellows. The bellows are easy to mount and provide excellent dust protection. If needed, please refer to III-26 for ordering.

Precaution for Use

① Mounting surface, reference mounting surface and typical mounting structure

When mounting the LWF series, properly align the reference mounting surface B and D of the track rail and slide unit with the reference mounting surface of the table and bed and fix them. (See Fig. 3.)

The reference mounting surfaces B and D and mounting surfaces A and C are precisely ground. Machining the mounting surface of the table and bed, such as machine or device, to high accuracy and mounting them properly will ensure stable linear motion with high accuracy.

Reference mounting surface of the slide unit is the opposite side of the  mark. The track rail reference mounting surface is identified by locating the  mark on the top surface of the track rail. It is the side surface above the mark (in the direction of the arrow). (See Fig. 4)

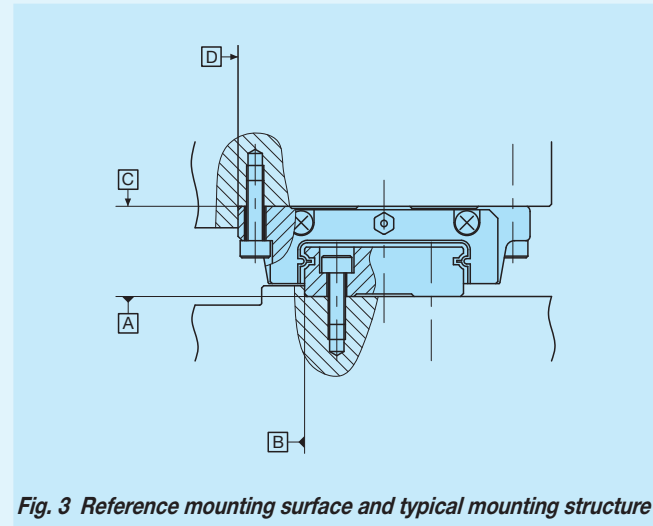

Fig. 3 Reference mounting surface and typical mounting structure

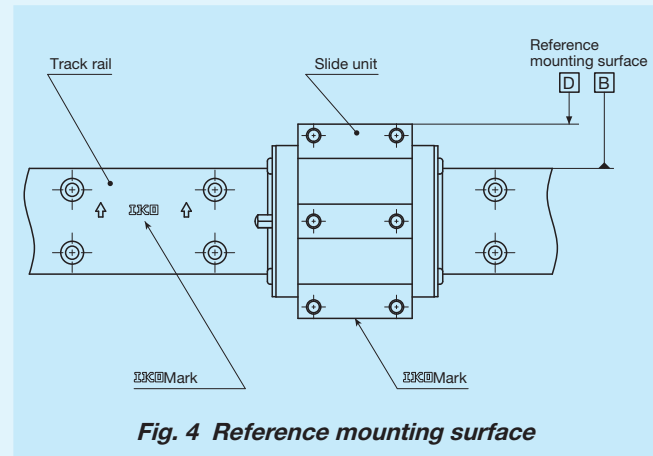

Fig. 4 Reference mounting surface

② Shoulder height and corner radius of the reference mounting surface

For the opposite corner of the mating reference mounting, it is recommended to have relieved fillet as indicated in Fig. 5. Recommended value for the shoulder height and corner radius on the mating side is indicated in Table 17.1 and Table 17.2.

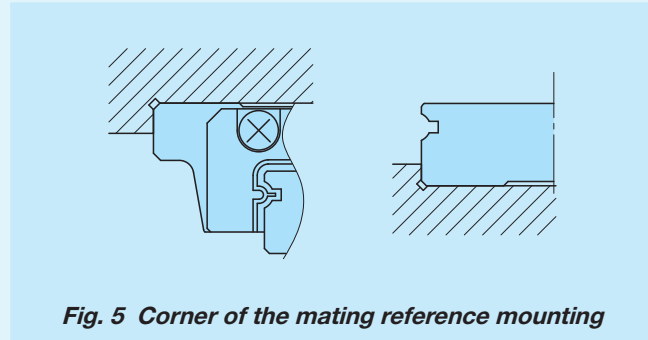

Fig. 5 Corner of the mating reference mounting

③ Tightening torque for fixing screw

Typical tightening torque for mounting of the LWF series to the steel mating member material is indicated in Table 16. When vibration and shock of the machine or device are large, fluctuating load is large, or moment load is applied, fix it by using the torque 1.2 to 1.5 times larger than the value indicated in the table as necessary. If the mating member material is cast iron or aluminum alloy, reduce the tightening torque depending on the strength characteristics of the mating member material.

Table 16 Tightening torque for fixing screw

Bolt size	Tightening torque N · m	
	High carbon steel-made screw	Stainless steel-made screw
M 4×0.7	4.1	2.5
M 5×0.8	8.0	5.0
M 6×1	13.6	8.5
M 8×1.25	32.7	—
M10×1.5	63.9	—

Remark: The tightening torque is calculated based on strength division 12.9 and property division A2-70.

Table 17.1 Shoulder height and corner radius of the reference mounting surface

Size	Mounting part of slide unit		Mounting part of track rail	
	Shoulder height h_1	Corner radius R (Maximum)	Shoulder height h_2	Corner radius R (Maximum)
33	4	0.4	2	0.4
37	5	0.4	2.5	0.4
42	5	0.4	2.5	0.4
69	5	0.8	3.5	0.8

unit: mm

Table 17.2 Shoulder height and corner radius of the reference mounting surface

Size	Mounting part of slide unit		Mounting part of track rail	Corner radius when supplemental code "/>
	Shoulder height h_1	Corner radius R (Maximum)	Shoulder height h_2	
40	4	0.3	3	1
60	6	0.5	4	1
90	8	0.5	6	1

unit: mm

Flange type mounting from top / bottom

Shape			
Size	40	60	90

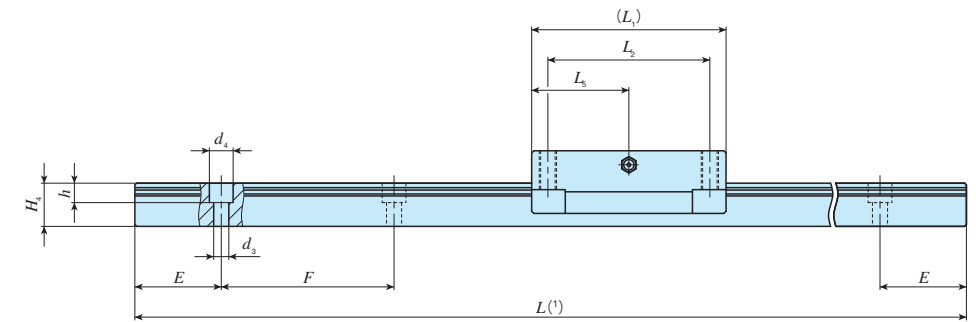
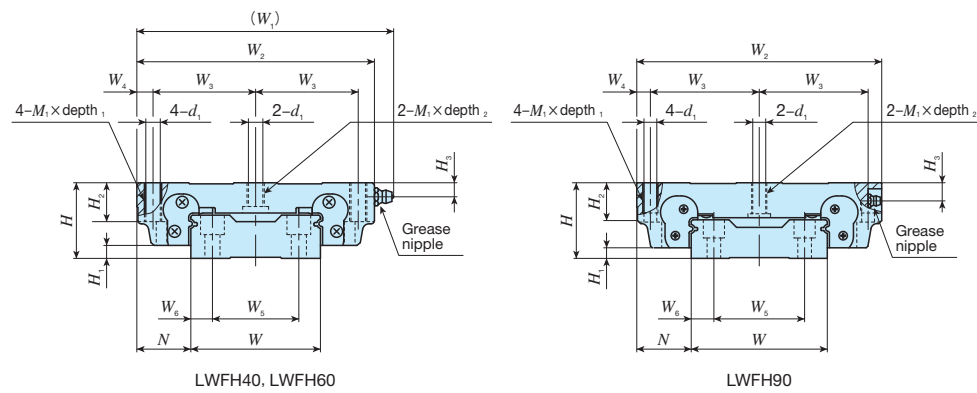

Identification number	Interchangeable	Mass(Ref.)		Dimensions of assembly			Dimensions of slide unit										Dimensions of track rail						Appended mounting bolt for track rail (2) mm	Basic dynamic load rating (3) C	Basic static load rating (3) C ₀	Static moment rating (3)							
		Slide unit kg	Track rail kg/m	H	H ₁	N	W ₁	W ₂	W ₃	W ₄	L ₁	L ₂	L ₃	d ₁	M ₁ ×depth ₁	depth ₂	H ₂	H ₃	W	H ₄	W ₅	W ₆				d ₃	d ₄	h	E	F	Bolt size×ℓ	N	N
LWFH 40	○	0.58	4.60	27	5	21	91	82	37	4	70	60	27.5	4.3	M 5×14	8	14	6.5	40	16	24	8	4.5	7.2	6	30	60	M4×16	12 600	16 600	280	108 612	99.3 563
LWFH 60	○	1.29	8.60	35	6	25	119	110	47.5	7.5	90	75	45	6.7	M 8×18	11	18	6.5	60	20	40	10	7	11	9	40	80	M6×22	16 100	23 500	600	210 1 090	193 998
LWFH 90	○	4.06	16.5	50	7	36	-	162	72	9	120	100	60	8.6	M10×20	20.5	26	12	90	25.5	60	15	9	14	12	40	80	M8×28	31 600	43 300	1 650	513 2 680	470 2 460

Notes (1) Track rail lengths L are shown in Table 2.1 on page II - 138.
 (2) The appended track rail mounting bolts are hexagon socket head bolts equivalent to JIS B 1176. For size 40, small-head bolts are appended.
 (3) The direction of basic dynamic load rating (C), basic static load rating (C_0), and static moment rating (T_0 , T_x , T_y) are shown in the sketches below. The upper values of T_x and T_y are for one slide unit and the lower values are for two slide units in close contact.
 Remark: The specifications of grease nipple are shown in Table 15 on page II - 146.

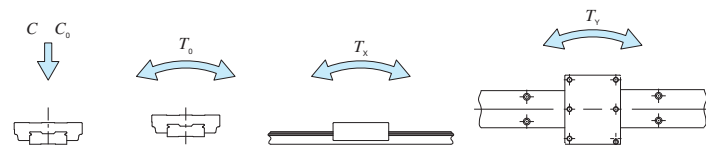

Example of identification number of assembled set

Model code Dimensions Part code Preload symbol Classification symbol Interchangeable code Supplemental code

LWFH **60** **C2** **R800** **T1** **P** **/U**

① ② ③ ④ ⑤ ⑥ ⑦ ⑧

① Model LWFH Flange type mounting from top / bottom	⑤ Preload amount No symbol Standard T1 Light preload T2 Medium preload	⑦ Interchangeable No symbol Non-interchangeable specification S1 S1 specification S2 S2 specification
② Size 40, 60, 90	⑥ Accuracy class H High P Precision SP Super precision	⑧ Special specification A, C, D, E, F, I, J, L, LF MN, N, Q, U, W, Y, Z
③ Number of slide unit (2)		
④ Length of track rail (800 mm)		

Flange type mounting from top / bottom

Shape				
Size	33	37	42	69

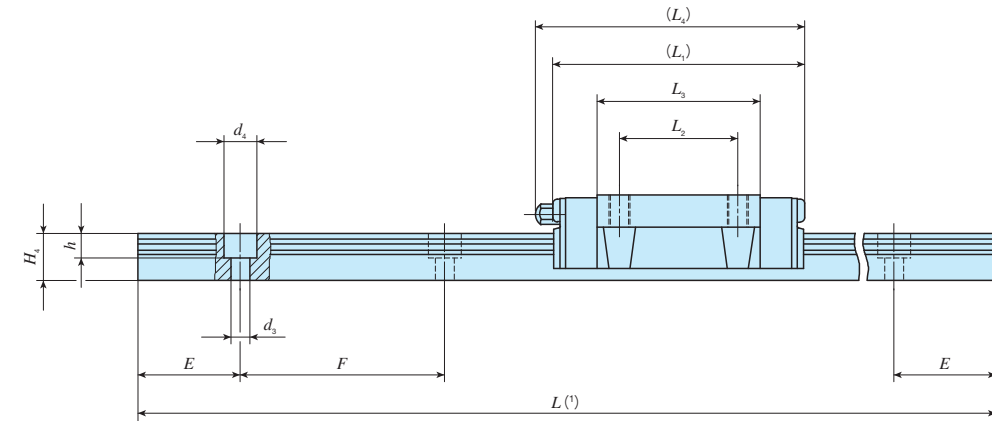
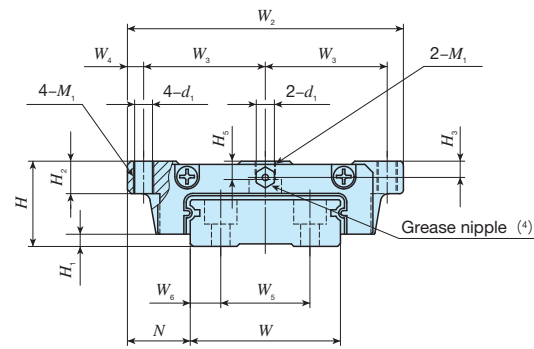

Identification number	Interchangeable	Mass(Ref.)		Dimensions of assembly			Dimensions of slide unit											Dimensions of track rail						Appended mounting bolt for track rail (2) mm	Basic dynamic load rating (3) N	Basic static load rating (3) N	Static moment rating (3)						
		Slide unit kg	Track rail kg/m	H	H ₁	N	W ₂	W ₃	W ₄	L ₁	L ₂	L ₃	L ₄	d ₁	M ₁	H ₂	H ₃	H ₅	W	H ₄	W ₅	W ₆	d ₃				d ₄	h	E	F	Bolt size × ℓ	C	C ₀
LWFF 33	○	0.14	2.41	17	2.5	13.5	60	26.5	3.5	54	26	35.3	56	3.3	M4	6	3.2	3.7	33	10	18	7.5	4.6	8	6	20	40	M4×10	6 530	8 610	146	49.0 292	49.0 292
LWFF 37	○	0.23	3.05	21	3	15.5	68	30	4	62	29	40	66	4.4	M5	8	4	4.5	37	11.5	22	7.5	4.6	8	6	25	50	M4×12	9 840	12 200	235	80.0 480	80.0 480
LWFF 42	○	0.49	4.30	27	3	19	80	35	5	75	40	52.2	86	5.3	M6	10	6	7	42	14	24	9	4.6	8	6	30	60	M4×16	15 500	19 400	424	165 904	165 904
LWFF 69	○	1.40	9.51	35	4	25.5	120	53.5	6.5	109	60	79.5	120	7	M8	14	8	8	69	19.5	40	14.5	7	11	9	40	80	M6×22	34 900	44 100	1 560	581 2 940	488 2 460

Notes (1) Track rail lengths L are shown in Table 2.1 on page II – 138.
 (2) The appended track rail mounting bolts are hexagon socket head bolts equivalent to JIS B 1176.
 (3) The direction of basic dynamic load rating (C), basic static load rating (C_0), and static moment rating (T_0 , T_x , T_y) are shown in the sketches below. The upper values of T_x and T_y are for one slide unit and the lower values are for two slide units in close contact.
 (4) The shapes of grease nipple vary by size. The specifications are shown in Table 15 on page II – 146.

LWFF

Example of identification number of assembled set

Model code Dimensions Part code Preload symbol Classification symbol Interchangeable code Supplemental code

LWFF **37** **C2** **R800** **T1** **P** **/U**

① ② ③ ④ ⑤ ⑥ ⑦ ⑧

① Model LWFF Flange type mounting from top / bottom	⑤ Preload amount No symbol Standard T1 Light preload T2 Medium preload	⑦ Interchangeable No symbol Non-interchangeable specification S1 S1 specification S2 S2 specification
② Size 33, 37, 42, 69	⑥ Accuracy class H High P Precision SP Super precision	⑧ Special specification A, D, E, F, I, J, L, LF MN, N, Q, U, V, W, Y, Z
③ Number of slide unit (2)		
④ Length of track rail (800 mm)		

Block type mounting from top

Shape			
Size	33	37	42

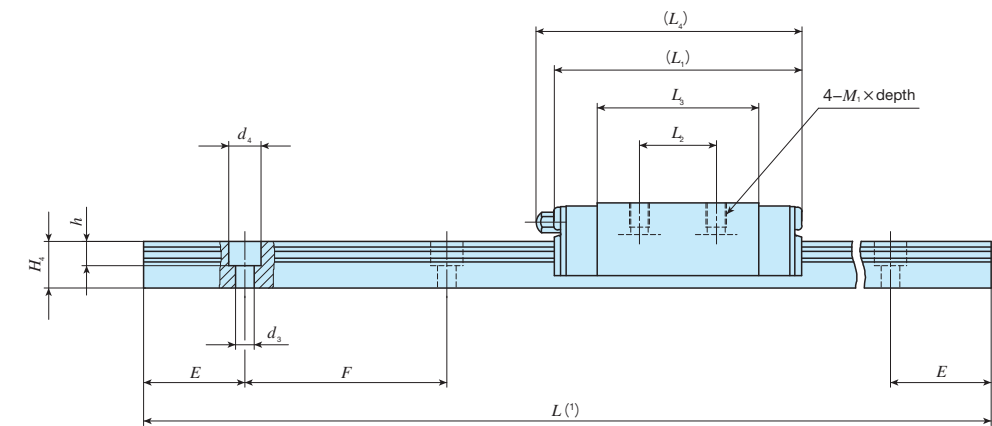
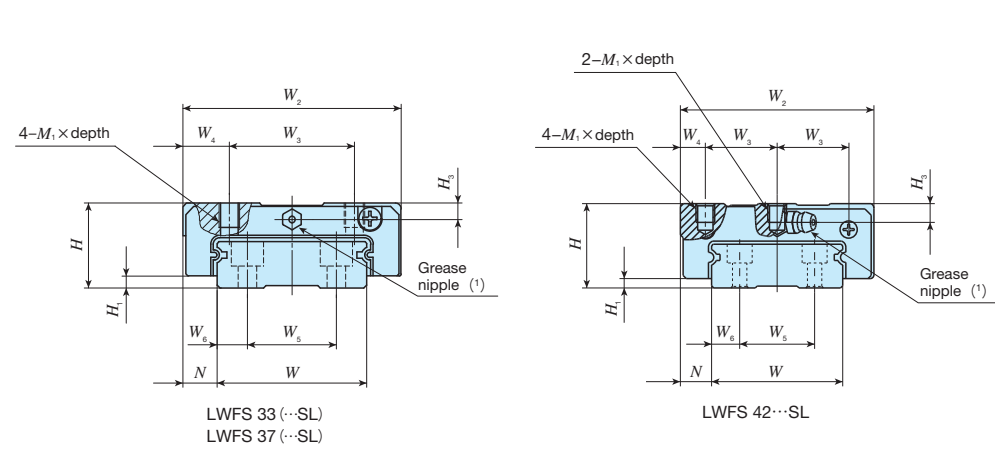

Identification number	Interchangeable	Mass(Ref.)		Dimensions of assembly			Dimensions of slide unit									Dimensions of track rail						Appended mounting bolt for track rail (2) mm	Basic dynamic load rating (3) N	Basic static load rating (3) N	Static moment rating (3)							
		Slide unit kg	Track rail kg/m	H	H ₁	N	W ₂	W ₃	W ₄	L ₁	L ₂	L ₃	L ₄	M ₁ × depth	H ₃	W	H ₄	W ₅	W ₆	d ₃	d ₄				h	E	F	T ₀	T _x	T _y		
LWFS 33	○	0.13	2.41	17	2.5	8.5	50	29	10.5	54	15	35.3	56	M4×5	3.2	33	10	18	7.5	4.6	8	6	20	40	M4×10	6 530	8 610	146	49.0 292 ⁰	49.0 292 ⁰		
LWFS 33...SL	○			LWFS 37	○	0.20	3.05	21	3	8.5	54	31	11.5	62	19	40	66	M5×6	4	37	11.5	22	7.5	4.6	8	6	25	50	M4×12	9 840	12 200	235
LWFS 37...SL	○	LWFS 42...SL	○	0.40	4.30			27	3	10	62	23	8	75	32	52.2	86	M6×6	6	42	14	24	9	4.6	8	6	30	60	M4×16	15 500	19 400	424

Notes (1) Track rail lengths L are shown in Tables 2.1 and 2.2 on page II - 138.
 (2) The appended track rail mounting bolts are hexagon socket head bolts equivalent to JIS B 1176. For stainless steel model, stainless steel bolts are appended.
 (3) The direction of basic dynamic load rating (C), basic static load rating (C_0), and static moment rating (T_0 , T_x , T_y) are shown in the sketches below. The upper values of T_x and T_y are for one slide unit and the lower values are for two slide units in close contact.
 (4) The shapes of grease nipple vary by size. The specifications are shown in Table 15 on page II - 146.

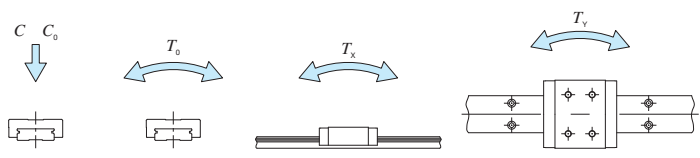

Example of identification number of assembled set

Model code: LWFS Dimensions: 37 Part code: C2 Material code: R800 Preload symbol: T1 Classification symbol: P Interchangeable code: /U

① Model: LWFS Block type mounting from top
 ② Size: 33, 37, 42
 ③ Number of slide unit (2)
 ④ Length of track rail (800 mm)
 ⑤ Material type: High carbon steel made, Stainless steel made
 ⑥ Preload amount: Standard, Light preload, Medium preload
 ⑦ Accuracy class: H, P, SP
 ⑧ Interchangeable: No symbol, Non-interchangeable specification
 ⑨ Special specification: A, D, E, F, I, J, L, LF, MN, N, Q, U, V, W, Y, Z