

## A-5-1.1 LH Series

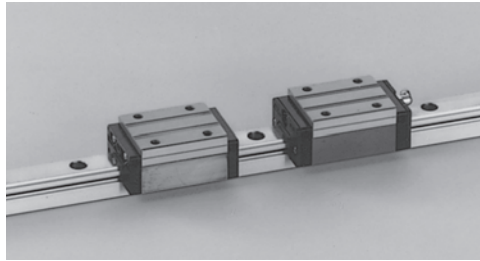

are also available in random matching. (Special high-carbon steel products for LH15 to LH45)

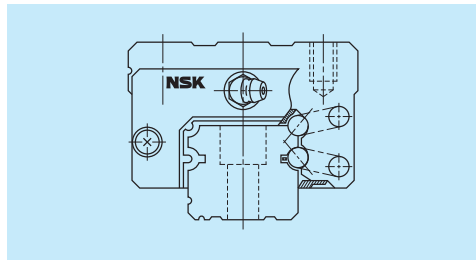

Fig. 1 LH Series

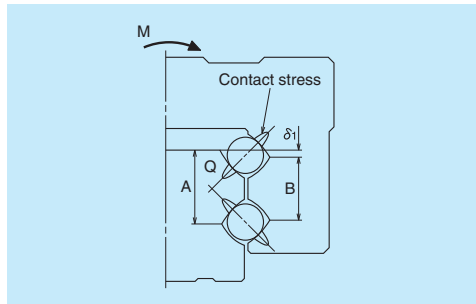

Fig. 2 Enlarged illustration of the offset Gothic arch groove

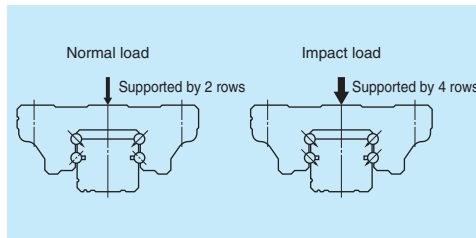

Fig. 3 When load is applied

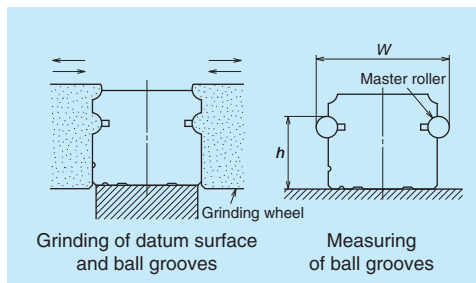

Fig. 4 Rail grinding and measuring

### 1. Features

#### (1) High self-aligning capability (rolling direction)

Same as the DF combination in angular contact bearings, self-aligning capability is high because the cross point of the contact lines of balls and grooves comes inside, and thus reducing moment rigidity.

This increases the capacity to absorb errors in installation.

#### (2) High load carrying capacity to vertical direction

The contact angle is set at 50 degrees, and thus increasing load carrying capacity as well as rigidity in vertical direction.

#### (3) High resistance against impact load

The bottom ball groove is formed in Gothic arch and the center of the top and bottom grooves are offset as shown in Fig. 2. The vertical load is generally carried by the top ball rows, where balls are contacting at two points. Because of this design, the bottom ball rows will carry load when a large impact load is applied vertically as shown in Fig. 3. This assures high resistance to the impact load.

#### (4) High accuracy

As showing in Fig. 4, fixing the master rollers to the ball grooves is easy thanks to the Gothic arch groove. This makes easy and accurate measuring of ball grooves.

#### (5) Easy to handle, and designed with safety in mind.

Balls are retained in the retainer, therefore they do not fall out when the ball slide is withdrawn from the rail. (LH10 to LH65)

#### (6) Abundant models and sizes

Each size of LH Series has various models of ball slides, rendering the linear guide available for numerous uses.

#### (7) Fast delivery

Lineup of random-matching rails and ball slides supports and facilitates fast delivery. (LH15 to LH65)

High precision grade and medium preload types

## 2. Ball slide shape

Ball slide Model	Shape/installation method	Type (Upper row, Rating: Lower row, Ball slide length)	
		High-load type Standard	Super-high-load type Long
AN BN		AN 	BN 
AL BL		AL 	BL 
EM GM		EM 	GM 
EL GL		EL 	GL 
FL HL		FL 	HL 

Note: High-precision grade and medium preload of random-matching type are not applicable to EL, GL, FL, and HL models.

3. Accuracy and preload

(1) Running parallelism of ball slide

Table 1

Unit:  $\mu\text{m}$

Rail length (mm) over or less	Preloaded assembly (not random matching)					Random-matching type	
	Ultra precision P3	Super precision P4	High precision P5	Precision grade P6	Normal grade PN	High precision PH	Normal grade PC
- 50	2	2	2	4.5	6	2	6
50 - 80	2	2	3	5	6	3	6
80 - 125	2	2	3.5	5.5	6.5	3.5	6.5
125 - 200	2	2	4	6	7	4	7
200 - 250	2	2.5	5	7	8	5	8
250 - 315	2	2.5	5	8	9	5	9
315 - 400	2	3	6	9	11	6	11
400 - 500	2	3	6	10	12	6	12
500 - 630	2	3.5	7	12	14	7	14
630 - 800	2	4.5	8	14	16	8	16
800 - 1 000	2.5	5	9	16	18	9	18
1 000 - 1 250	3	6	10	17	20	10	20
1 250 - 1 600	4	7	11	19	23	11	23
1 600 - 2 000	4.5	8	13	21	26	13	26
2 000 - 2 500	5	10	15	22	29	15	29
2 500 - 3 150	6	11	17	25	32	17	32
3 150 - 4 000	9	16	23	30	34	23	34

Notes: 1) High-precision grade of random-matching type is available in LH15 to LH45.  
2) LH08, 10, and 12 are not available in random-matching type. For LH08, 10, and 12, accuracy of P4, P5, P6, and PN grades are available.

(2) Accuracy standard

The preloaded assembly has five accuracy grades; Ultra precision P3, Super precision P4, High precision P5, Precision P6 and Normal PN grades, while the random-matching type has High precision PH and Normal PC grade.

• Tolerance of preloaded assembly

Table 2

Unit:  $\mu\text{m}$

Characteristics	Accuracy grade	Ultra precision P3	Super precision P4	High precision P5	Precision grade P6	Normal grade PN
Mounting height $H$ Variation of $H$ (All ball slides on a set of rails)		$\pm 10$ 3	LH08,10,12 LH15 - $\pm 10$ $\pm 10$ 3 5	LH08,10,12 LH15 - $\pm 20$ $\pm 20$ 5 7	LH08,10,12 LH15 - $\pm 40$ $\pm 40$ 7 15	LH08,10,12 LH15 - $\pm 80$ $\pm 80$ 15 25
Mounting width $W_2$ or $W_3$ Variation of $W_2$ or $W_3$ (All ball slides on reference rail)		$\pm 15$ 3	LH08,10,12 LH15 - $\pm 10$ $\pm 15$ 5 7	LH08,10,12 LH15 - $\pm 15$ $\pm 25$ 7 10	LH08,10,12 LH15 - $\pm 25$ $\pm 50$ 10 20	LH08,10,12 LH15 - $\pm 50$ $\pm 100$ 20 30
Running parallelism of surface C to surface A Running parallelism of surface D to surface B		Shown in Table 1, Fig. 5, and Fig. 6				

Note: For LH08, 10, and 12, accuracy of P4, P5, P6, and PN grades are available.

• Tolerance of random-matching type

Table 3

Unit:  $\mu\text{m}$

Accuracy grade	High precision grade PH		Normal grade PC		
Characteristics	Model No.	LH15, 20, 25, 30, 35	LH45	LH15, 20, 25, 30, 35	LH45, 55, 65
Mounting height $H$		$\pm 20$	$\pm 30$	$\pm 20$	$\pm 30$
Variation of mounting height $H$		15① 30②	20① 35②	15① 30②	20① 35②
Mounting width $W_2$ or $W_3$		$\pm 30$	$\pm 35$	$\pm 30$	$\pm 35$
Variation of mounting width $W_2$ or $W_3$		20	30	25	30
Running parallelism of surface C to surface A Running parallelism of surface D to surface B		See Table 1, Fig. 5 and Fig. 6			

Notes: 1) LH08, 10 and 12 are not available in the random-matching type.  
2) ① Variation on the same rail ② Variation on multiple rails

(3) Combinations of accuracy and preload

Table 4

	Accuracy grade							
	Ultra precision	Super precision	High precision	Precision grade	Normal grade	High precision	Normal grade	
Without NSK K1 lubrication unit	P3	P4	P5	P6	PN	PH	PC	
With NSK K1 lubrication unit	K3	K4	K5	K6	KN	KH	KC	
With NSK K1 for food and medical equipment	F3	F4	F5	F6	FN	FH	FC	
Preload	Fine clearance Z0	○	○	○	○	○	—	—
	Slight preload Z1	○	○	○	○	○	—	—
	Medium preload Z3	○	○	○	○	—	—	—
	Random-matching type with fine clearance ZT	—	—	—	—	—	—	○
	Random-matching type with slight preload ZZ	—	—	—	—	—	○	○
	Random-matching type with medium preload ZH	—	—	—	—	—	○	○

Notes: 1) Medium preload of random-matching type is available in LH15 to LH45.  
2) LH08, 10, and 12 are not available in random-matching type.

(4) Assembled accuracy

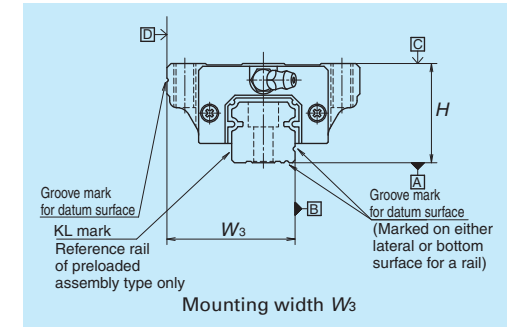
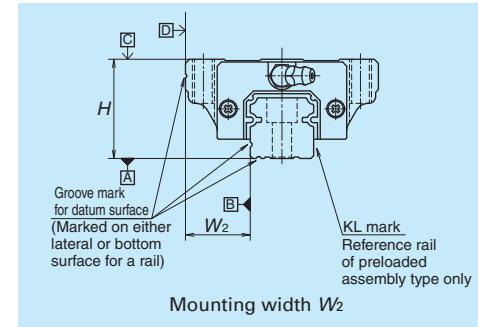

Fig. 5 Special high carbon steel

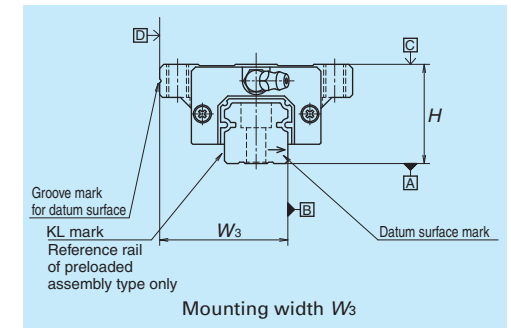
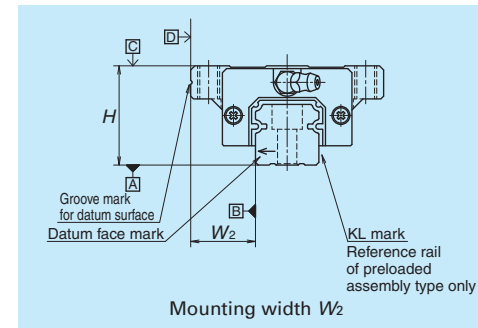

Fig. 6 Stainless steel

**(5) Preload and rigidity**

We offer six levels of preload: Slight preload Z1, Medium preload Z3 and Fine clearance Z0, along with random-matching type of Medium preload ZH, Slight preload ZZ and Fine clearance ZT.

• **Preload and rigidity of preloaded assembly**

**Table 5**

Model No.	Preload (N)		Rigidity (N/ $\mu$ m)			
			Vertical direction		Lateral direction	
	Slight preload Z1	Medium preload Z3	Slight preload Z1	Medium preload Z3	Slight preload Z1	Medium preload Z3
LH08 AN	5	—	33	—	23	—
LH10 AN	9	—	44	—	31	—
LH12 AN	22	—	68	—	47	—
LH15 AN, EM, EL, FL	78	490	137	226	98	186
LH20 AN, EM, EL, FL	147	835	186	335	137	245
LH25 AL, AN, EM, EL, FL	196	1 270	206	380	147	284
LH30 AL, AN	245	1 570	216	400	157	294
LH30 EM, EL, FL	294	1 770	265	480	186	355
LH35 AL, AN, EM, EL, FL	390	2 350	305	560	216	390
LH45 AN, AL, EM, EL, FL	635	3 900	400	745	284	540
LH55 AN, EM, EL, FL	980	5 900	490	910	345	645
LH65 AN, EM, EL, FL	1 470	8 900	580	1 070	400	755
LH15 BN, GM, GL, HL	98	685	196	345	137	284
LH20 BN, GM, GL, HL	196	1 080	265	480	196	355
LH25 BL, BN, GM, GL, HL	245	1 570	294	560	216	400
LH30 BL, BN, GM, GL, HL	390	2 260	360	665	265	480
LH35 BL, BN, GM, GL, HL	490	2 940	430	795	305	570
LH45 BL, BN, GM, GL, HL	785	4 800	520	960	370	695
LH55 BL, BN, GM, GL, HL	1 180	7 050	635	1 170	440	835
LH65 BL, BN, GM, GL, HL	1 860	11 300	805	1 480	550	1 040

Note: Clearance for Fine clearance Z0 is 0 to 3 $\mu$ m. Therefore, preload is zero. However, Z0 of PN grade is 0 to 15 $\mu$ m.

• **Clearance and preload of random-matching type**

**Table 6**

Unit:  $\mu$ m

Model No.	Fine clearance ZT	Slight preload ZZ	Medium preload ZH
LH15	-4 — 15	-4 — 0	-8 — -3.5
LH20	-5 — 15	-5 — 0	-9 — -3.5
LH25		-5 — 0	-11 — -5.5
LH30		-7 — 0	-13 — -6
LH35		-7 — 0	-14 — -7
LH45		-7 — 0	-17 — -9
LH55		-9 — 0	
LH65		-9 — 0	

Notes: 1) Minus sign denotes that a value is an amount of preload (elastic deformation of balls).  
2) LH08, 10, and 12 are not available in random-matching type.

**4. Maximum rail length**

**Table 7** shows the limitations of rail length (maximum length). However, the limitations vary by accuracy grades.

**Table 7 Length limitations of rails**

Unit: mm

Series	Material	Size										
		08	10	12	15	20	25	30	35	45	55	65
LH	Special high carbon steel				2 000	3 960	3 960	4 000	4 000	3 990	3 960	3 900
	Stainless steel	375	600	800	1 800	3 500	3 500	3 500				

Note: Rails can be butted if user requirement exceeds the rail length shown in the table. Please consult NSK.

**5. Installation**

**(1) Permissible values of mounting error**

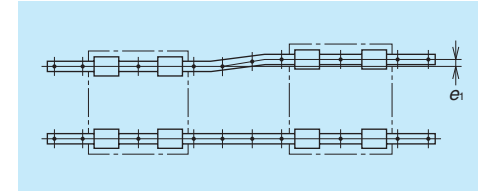

**Fig. 7**

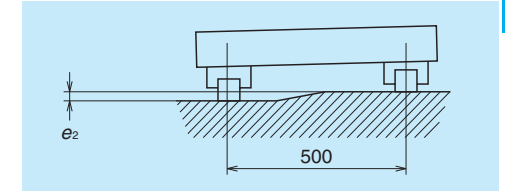

**Fig. 8**

**Table 8**

Unit:  $\mu$ m

Value	Preload	Model No.										
		LH08	LH10	LH12	LH15	LH20	LH25	LH30	LH35	LH45	LH55	LH65
Permissible values of parallelism in two rails $e_1$	Z0, ZT	9	12	19	22	30	40	45	55	65	80	110
	Z1, ZZ	8	11	18	18	20	25	30	35	45	55	70
	Z3, ZH	—	—	—	13	15	20	25	30	40	45	60
Permissible values of parallelism (height) in two rails $e_2$	Z0, ZT	375 $\mu$ m/500 mm										
	Z1, ZZ, Z3, ZH	330 $\mu$ m/500 mm										

**(2) Shoulder height of the mounting surface and corner radius  $r$**

**Table 9**

Unit: mm

Model No.	Corner radius (maximum)		Shoulder height	
	$r_a$	$r_b$	$H'$	$H''$
LH08	0.3	0.5	1.8	3
LH10	0.3	0.5	2.1	4
LH12	0.5	0.5	2.7	4
LH15	0.5	0.5	4	4
LH20	0.5	0.5	4.5	5
LH25	0.5	0.5	5	5
LH30	0.5	0.5	6	6
LH35	0.5	0.5	6	6
LH45	0.7	0.7	8	8
LH55	0.7	0.7	10	10
LH65	1	1	11	11

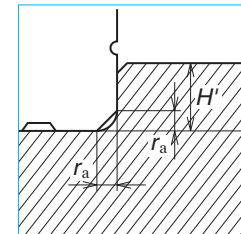

**Fig. 9 Shoulder for the rail datum surface**

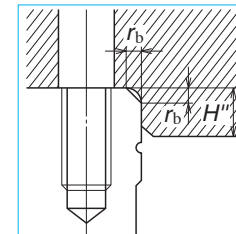

**Fig. 10 Shoulder for the ball slide datum surface**

## 6. Lubrication components

Refer to pages A38 and D13 for the lubrication of linear guides.

### (1) Types of lubrication accessories

Fig. 11 and Table 10 show grease fittings and tube fittings.

We provide lubrication accessories with extended thread body length (L) for the addition of dust-proof accessories such as NSK K1 lubrication unit, double seal and protector.

We provide a suitable lubrication accessory for the special requirement on dust-proof accessories.

Consult NSK for a lubrication accessory with extended length of thread body for your convenience of replenishing lubricant.

When you require stainless lubrication accessories, please ask NSK.

### (2) Mounting position of lubrication accessories

The standard position of grease fittings is the end face of ball slide. We mount them on a side of end cap for an option. (Fig. 12)

Please consult NSK for installation of grease or tube fittings to the ball slide body or side of end cap.

When using a piping unit with thread of M6 × 1, you require a connector to connect to a grease fitting mounting hole with M6 × 0.75. The connector is available from NSK.

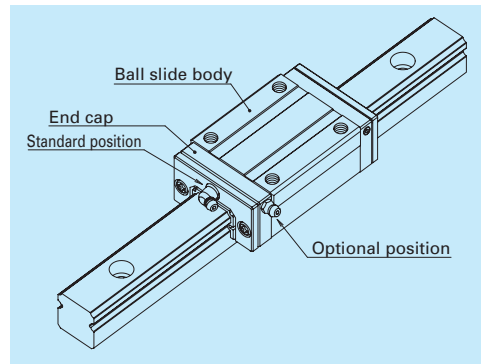

Fig. 12 Mounting position of lubrication accessories

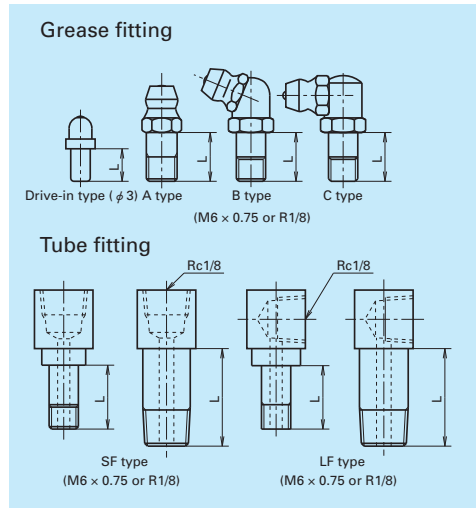

Fig. 11 Grease fitting and tube fitting

Model No.	Dust-proof specification	Grease fitting		Tube fitting	
		Thread body length L	Thread body length L	Thread body length L	Thread body length L
LH12	Standard	5	-	-	-
	With NSK K1	10	-	-	-
	Double seal	*	-	-	-
	Protector	*	-	-	-
LH15	Standard	5	-	-	-
	With NSK K1	10	-	-	-
	Double seal	*	-	-	-
	Protector	*	-	-	-
LH20	Standard	5	-	-	-
	With NSK K1	12	-	-	-
	Double seal	10	-	-	-
	Protector	10	-	-	-
LH25	Standard	5	5	5	5
	With NSK K1	12	12	12	12
	Double seal	10	9	9	9
	Protector	10	9	9	9
LH30	Standard	5	6	6	6
	With NSK K1	14	13	13	13
	Double seal	12	11	11	11
	Protector	12	11	11	11
LH35	Standard	5	6	6	6
	With NSK K1	14	13	13	13
	Double seal	12	11	11	11
	Protector	12	11	11	11
LH45	Standard	8	17	17	17
	With NSK K1	18	21.5	21.5	21.5
	Double seal	14	17	17	17
	Protector	14	17	17	17
LH55	Standard	8	17	17	17
	With NSK K1	18	21.5	21.5	21.5
	Double seal	14	17	17	17
	Protector	14	17	17	17
LH65	Standard	8	17	17	17
	With NSK K1	20	25.5	25.5	25.5
	Double seal	16	19	19	19
	Protector	16	19	19	19

\*) A connector is required for this model. Please contact NSK for grease fittings.

## 7. Dust-proof components

### (1) Standard specification

The LH Series can be readily used as they have a dust protection means for normal conditions. As the standard equipment, the ball slides have an end seal on both ends, and bottom seals at the bottom. However, the bottom seals are not used to LH08 and 10.

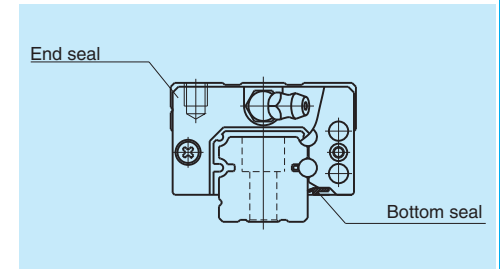

Fig. 13

Table 11 Seal friction per ball slide (maximum value)

Series	Size	Unit: N										
		08	10	12	15	20	25	30	35	45	55	65
LH		0.5	1	1.5	8	9	10	10	12	17	22	29

### (2) NSK K1™ lubrication unit

Table 12 shows the dimension of linear guides equipped with the NSK K1 lubrication unit.

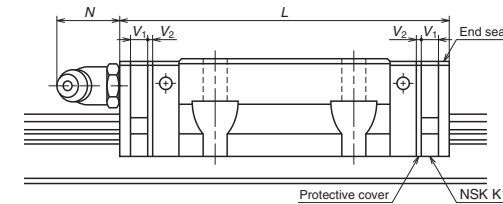

Table 12

Model No.	Ball slide length	Ball slide model	Standard ball slide length	Ball slide length installed with two NSK K1 L	Per NSK K1 thickness V <sub>1</sub>	Protective cover thickness V <sub>2</sub>	Protruding area of the grease fitting N
LH08	Standard	AN	24	31	3	0.5	—
LH10	Standard	AN	31	40	4	0.5	—
LH12	Standard	AN	45	54	4	0.5	(4)
LH15	Standard	AN, EM, EL, FL	55	65.6	4.5	0.8	(5)
	Long	BN, GM, GL, HL	74	84.6			
LH20	Standard	AN, EM, EL, FL	69.8	80.4	4.5	0.8	(14)
	Long	BN, GM, GL, HL	91.8	102.4			
LH25	Standard	AL, AN, EM, EL, FL	79.0	90.6	5.0	0.8	(14)
	Long	BL, BN, GM, GL, HL	107	118.6			
LH30	Standard	AL, AN	85.6	97.6	5.0	1.0	(14)
	Flange type	EM, EL, FL	98.6	110.6			
LH35	Standard	AL, AN, EM, EL, FL	109	122	5.5	1.0	(14)
	Long	BL, BN, GM, GL, HL	143	156			
LH45	Standard	AL, AN, EM, EL, FL	139	154	6.5	1.0	(15)
	Long	BL, BN, GM, GL, HL	171	186			
LH55	Standard	AL, AN, EM, EL, FL	163	178	6.5	1.0	(15)
	Long	BL, BN, GM, GL, HL	201	216			
LH65	Standard	AN, EM, EL, FL	193	211	8.0	1.0	(16)
	Long	BN, GM, GL, HL	253	271			

Notes: 1) NSK K1 for food and medical equipments are available for LH12 to LH35.

2) Ball slide length equipped with NSK K1 = (Standard ball slide length) + (Thickness of NSK K1, V<sub>1</sub> × Number of NSK K1) + (Thickness of the protective cover, V<sub>2</sub> × 2)

**(3) Double seal**

Use a double seal set as showing in **Table 13**, when installing an extra seal to completed standard products. **(Fig. 14)**

When installing a grease fitting after the installation of double seals, a connector as showing in **Fig.14** is required.

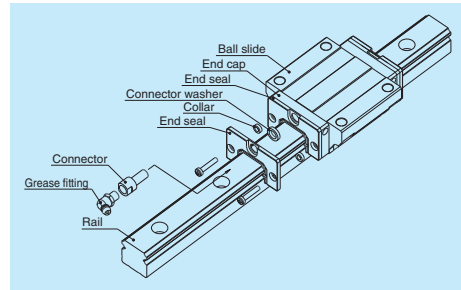
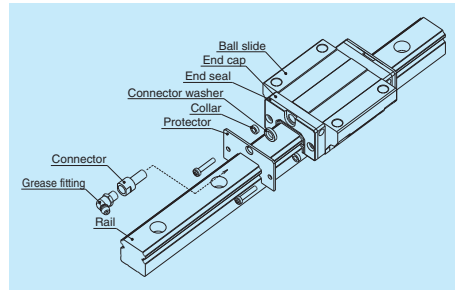

**Fig. 14 Double seal**

**(4) Protector**

Use a protector set as showing **Table 14**, when installing a protector to completed standard products. **(Fig.15)**

When installing a grease fitting after the installation of protectors, a connector as showing in **Fig.15** is required.



**Fig. 15 Protector**

**Table 13 Double-seal set**

Model No.	Reference No.		Increased thickness $V_3$ (mm)
	Without connector	With connector	
LH15	LH15WS-01	*	2.5
LH20	LH20WS-01	LH20WSC-01	2.5
LH25	LH25WS-01	LH25WSC-01	2.8
LH30	LH30WS-01	LH30WSC-01	3.6
LH35	LH35WS-01	LH35WSC-01	3.6
LH45	LH45WS-01	LH45WSC-01	4.3
LH55	LH55WS-01	LH55WSC-01	4.3
LH65	LH65WS-01	LH65WSC-01	4.9

**Table 14 Protector set**

Model No.	Reference No.		Increased thickness $V_4$ (mm)
	Without connector	With connector	
LH15	LH15PT-01	*	2.7
LH20	LH20PT-01	LH20PTC-01	2.9
LH25	LH25PT-01	LH25PTC-01	3.2
LH30	LH30PT-01	LH30PTC-01	4.2
LH35	LH35PT-01	LH35PTC-01	4.2
LH45	LH45PT-01	LH45PTC-01	4.9
LH55	LH55PT-01	LH55PTC-01	4.9
LH65	LH65PT-01	LH65PTC-01	5.5

\*) For installation of a connector to a drive-in type grease fitting, contact NSK.

Note: Double seal and protector for LH08, 10, and 12, please consult NSK.

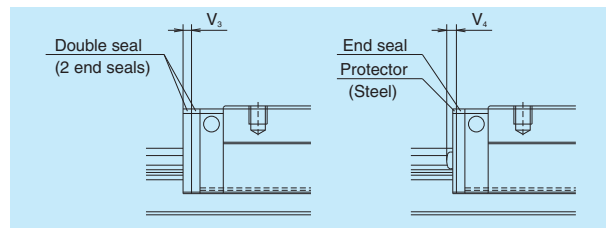

**Fig. 16**

**(5) Cap to plug the rail mounting bolt hole**

**Table 15 Caps to plug rail bolt hole**

Model No.	Bolt to secure rail	Cap reference No.	Quantity /case
LH12	M3	LG-CAP/M3	20
LH15	M4	LG-CAP/M4	20
LH20	M5	LG-CAP/M5	20
LH25	M6	LG-CAP/M6	20
LH30, LH35	M8	LG-CAP/M8	20
LH45	M12	LG-CAP/M12	20
LH55	M14	LG-CAP/M14	20
LH65	M16	LG-CAP/M16	20

**(7) Bellows**

- A bellows fastener kit, which includes one of bellows faster, two of  $M_1$  set screws, two of  $M_2$  set screws, and two collars for  $M_2$  set screws as showing Fig. 7.7 on page A55, is supplied with ellows for the ends.

- Middle bellows are supplied with four set screws and four collars.

- Use a bellows fastener kit as showing **Table 17**, when installing bellows to completed standard products.

- When NSK K1, double seals or protectors are used, the set screws of bellows fastener kit are unable to use.

Please contact NSK for details.

- Bellows fastener is available only for the horizontal mounting positions. For other mounting positions, sliding plate is required (see **Fig. 7.10** on page A56).

For fixing to the rail, make tap holes to the rail end surface. Fix the bellows mounting plate to the rail end surface through these tap holes by using a machine screw. NSK processes a tap hole to the rail end face when ordered with a linear guide.

- Please consult NSK for the bellows of LH08, 10, 12, and 15.

**(6) Inner seal**

Inner seal is only available for models shown in the table below.

**Table 16**

Series	Model No.
LH	LH20, LH25, LH30, LH35, LH45, LH55, LH65

**Table 17 Bellows fastner kit reference No.**

Model No.	Kit reference No.
LH20	LH20FS-01
LH25	LH25FS-01
LH30	LH30FS-01
LH35	LH35FS-01
LH45	LH45FS-01
LH55	LH55FS-01
LH65	LH65FS-01

**Dimension tables of bellows**  
**LH Series**

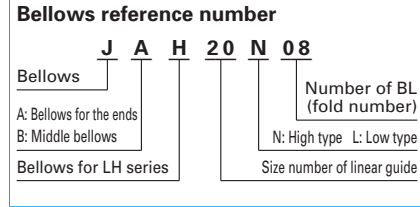
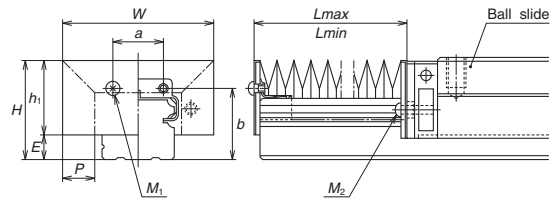

**Fig. 17 Dimensions of bellows**

**Table 18 Dimensions of bellows**

Unit: mm

Model No.	H	h <sub>1</sub>	E	W	P	a	b	BL minimum length	M <sub>1</sub> Tap x depth	M <sub>2</sub> Tap x depth
JAH20N	29.5	24.5	5	48	10	13	22	17	M3 × 5	M2.5 × 16
JAH25L	35	28	7	51	10	16	26	17	M3 × 5	M3 × 18
JAH25N	39	32		61	15					
JAH30L	41	32	9	60	12	18	31	17	M4 × 6	M4 × 22
JAH30N	44	35		66	15					
JAH35L	47	37.5	9.5	72	15	24	34	17	M4 × 6	M4 × 23
JAH35N	54	44.5		82	20					
JAH45L	59	45	14	83	15	32	44.5	17	M5 × 8	M5 × 28
JAH45N	69	55		103	25					
JAH55L	69	54	15	101	20	40	50.5	17	M5 × 8	M5 × 30
JAH55N	79	64		121	30					
JAH65N	89	73	16	131	30	48	61	17	M6 × 8	M6 × 35

**Table 19 Numbers of folds (BL) and lengths of bellows**

Unit: mm

Model No.	Number of BL	2	4	6	8	10	12	14	16	18	20
		L <sub>min</sub>	34	68	102	136	170	204	238	272	306
JAH20N	Stroke	106	212	318	424	530	636	742	848	954	1 060
	L <sub>max</sub>	140	280	420	560	700	840	980	1 120	1 260	1 400
JAH25L	Stroke	106	212	318	424	530	636	742	848	954	1 060
	L <sub>max</sub>	140	280	420	560	700	840	980	1 120	1 260	1 400
JAH25N	Stroke	176	352	528	704	880	1 056	1 232	1 408	1 584	1 760
	L <sub>max</sub>	210	420	630	840	1 050	1 260	1 470	1 680	1 890	2 100
JAH30L	Stroke	134	268	402	536	670	804	938	1 072	1 206	1 340
	L <sub>max</sub>	168	336	504	672	840	1 008	1 176	1 344	1 512	1 680
JAH30N	Stroke	176	352	528	704	880	1 056	1 232	1 408	1 584	1 760
	L <sub>max</sub>	210	420	630	840	1 050	1 260	1 470	1 680	1 890	2 100
JAH35L	Stroke	176	352	528	704	880	1 056	1 232	1 408	1 584	1 760
	L <sub>max</sub>	210	420	630	840	1 050	1 260	1 470	1 680	1 890	2 100
JAH35N	Stroke	246	492	738	984	1 230	1 476	1 722	1 968	2 214	2 460
	L <sub>max</sub>	280	560	840	1 120	1 400	1 680	1 960	2 240	2 520	2 800
JAH45L	Stroke	176	352	528	704	880	1 058	1 232	1 408	1 584	1 760
	L <sub>max</sub>	210	420	630	840	1 050	1 260	1 470	1 680	1 890	2 100
JAH45N	Stroke	316	632	948	1 264	1 580	1 896	2 212	2 528	2 844	3 160
	L <sub>max</sub>	350	700	1 050	1 400	1 750	2 100	2 450	2 800	3 150	3 500
JAH55L	Stroke	246	492	738	984	1 230	1 476	1 722	1 968	2 214	2 460
	L <sub>max</sub>	280	560	840	1 120	1 400	1 680	1 960	2 240	2 520	2 800
JAH55N	Stroke	386	772	1 158	1 544	1 930	2 316	2 702	3 088	3 474	3 860
	L <sub>max</sub>	420	840	1 260	1 680	2 100	2 520	2 940	3 360	3 780	4 200
JAH65N	Stroke	386	772	1 158	1 544	1 930	2 316	2 702	3 088	3 474	3 860
	L <sub>max</sub>	420	840	1 260	1 680	2 100	2 520	2 940	3 360	3 780	4 200

**Note:** The values of an odd number BL quantity (3, 5, 7, ...) can be obtained by adding two values of even number BL on the both sides, then by dividing the sum by 2.



**LH Series**

**8. Reference number**

Reference numbers shall be set to individual NSK linear guide when its specifications are finalized, and it is indicated on its specification drawing.  
Please specify the reference number, except design serial number, to identify the product when ordering, requiring estimates, or inquiring about specifications from NSK.

**(1) Reference number for preloaded assembly**

**LH 30 1200 ANC 2 -\*\* P5 3**

Series name	Preload code (See page A118.) 0: Z0, 1: Z1, 3: Z3
Size	Accuracy code (See Table 21.)
Rail length (mm)	Design serial number Added to the reference number.
Ball slide shape code (See page A116.)	Number of ball slides per rail
Material/surface treatment code (See Table 20.) C: Special high carbon steel (NSK standard), K: Stainless steel	

**(2) Reference number for random-matching type**

**LAH 30 ANSZ -K**

Ball slide	Option code -K: Equipped with NSK K1
Random-matching ball slide series code LAH: LH Series random-matching ball slide	-F: Fluoride low temperature chrome plating+AS2 grease -F50: Fluoride low temperature chrome plating+LG2 grease
Size	Preload code No code: Fine clearance, Z: Slight preload, H: Medium preload
Ball slide shape code (See page A116.)	Material code No code: Special high carbon steel (NSK standard), S: Stainless steel

**Rail L1H30 1200 LCN -\*\* PC Z**

Rail	Preload code (See page A118.) T: Fine clearance Z: Slight preload (common rail for slight or medium preload)
Random-matching rail series code L1H: LH Series random-matching rail	Accuracy code PH: High precision grade random-matching type PC: Normal grade random-matching type
Size	Design serial number Added to the reference number.
Rail length (mm)	*Butting rail specification N: Non-butting, L: Butting specification
Rail shape code: L L: Standard	
Material/surface treatment code (See Table 20.)	*Please consult with NSK for butting rail specification.

The reference number coding for the assembly of random-matching type is the same as that of the preloaded assembly. However, only preload codes of "fine clearance T", "slight preload Z" and "medium preload H" are available (refer to page A118).

**Table 20 Material/surface treatment code**

Code	Description
C	Special high carbon steel (NSK standard)
K	Stainless steel (LH08 to LH30 only)
D	Special high carbon steel with surface treatment
H	Stainless steel with surface treatment
Z	Other, special

Note: High-precision grade and medium preload of random-matching type are not available in stainless steel.

**Table 21 Accuracy code**

Accuracy	Standard (Without NSK K1)	With NSK K1	With NSK K1 for food and medical equipment
Ultra precision grade	P3	K3	F3
Super precision grade	P4	K4	F4
High precision grade	P5	K5	F5
Precision grade	P6	K6	F6
Normal grade	PN	KN	FN
High precision grade (random-matching type)	PH	KH	FH
Normal grade (random-matching type)	PC	KC	FC

Note: Refer to pages A38 and A61 for NSK K1 lubrication unit.

**9. Dimensions**  
**LH-AN (High-load type / Standard)**  
**LH-BN (Super-high-load type / Long)**

**LH 30 1200 ANC 2 -\*\* PC Z**

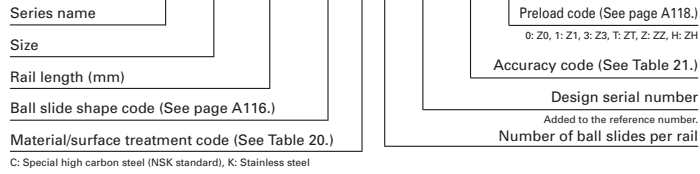

Front view of AN and BN types

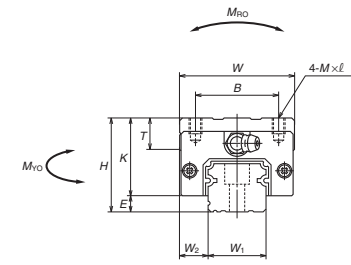

Side view of AN type

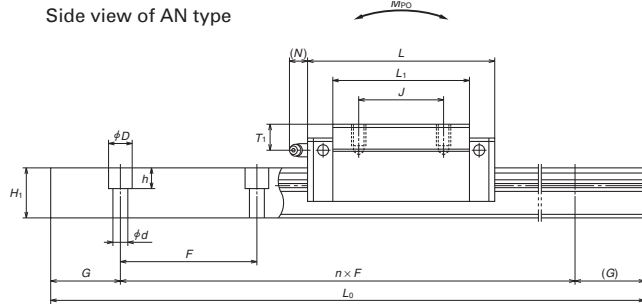

Side view of BN type

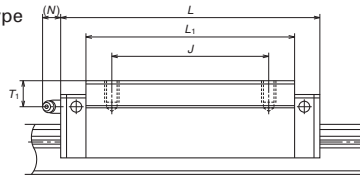

Model No.	Assembly			Ball slide											Width	Height	
	Height	E	W <sub>2</sub>	Width	Length	Mounting hole					Grease fitting			W <sub>1</sub>			H <sub>1</sub>
						B	J	M × pitch × l	L <sub>1</sub>	K	T	Hole size	T <sub>1</sub>				
LH08AN	11	2.1	4	16	24	10	10	M2×0.4×2.5	15	8.9	—	—	—	—	8	5.5	
LH10AN	13	2.4	5	20	31	13	12	M2.6×0.45×3	20.2	10.6	6	—	—	10	6.5		
LH12AN	20	3.2	7.5	27	45	15	15	M4×0.7×5	31	16.8	6	φ 3	5	4	12	10.5	
LH15AN	28	4.6	9.5	34	55	26	26	M4×0.7×6	39	23.4	8	φ 3	8.5	3.3	15	15	
LH15BN					74				58								
LH20AN	30	5	12	44	69.8	32	36	M5×0.8×6	50	25	12	M6×0.75	5	11	20	18	
LH20BN					91.8				72								
LH25AN	40	7	12.5	48	79	35	35	M6×1×9	58	33	12	M6×0.75	10	11	23	22	
LH25BN					107				86								
LH30AN	45	9	16	60	85.6	40	40	M8×1.25×10	59	36	14	M6×0.75	10	11	28	26	
LH30BN					124.6				98								
LH35AN	55	9.5	18	70	109	50	50	M8×1.25×12	80	45.5	15	M6×0.75	15	11	34	29	
LH35BN					143				114								
LH45AN	70	14	20.5	86	139	60	60	M10×1.5×17	105	56	17	Rc1/8	20	13	45	38	
LH45BN					171				137								
LH55AN	80	15	23.5	100	163	75	75	M12×1.75×18	126	65	18	Rc1/8	21	13	53	44	
LH55BN					201				164								
LH65AN	90	16	31.5	126	193	76	70	M16×2×20	147	74	23	Rc1/8	19	13	63	53	
LH65BN					253				207								

Notes: 1) LH08 does not have a ball retainer. Be aware that balls fall out when the ball slide is withdrawn from the rail.  
 2) External appearance of stainless steel ball slides differs from those of carbon steel ball slides.  
 3) Only stainless steel models are available for LH08 to LH12.

**Reference number for ball slide of random-matching type**

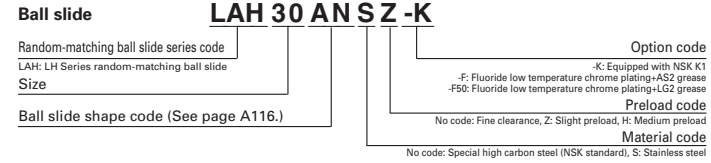

AN and BN types

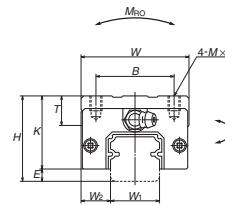

AN type

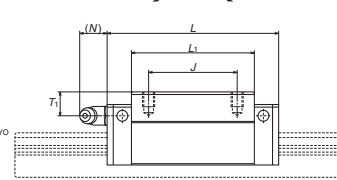

BN type

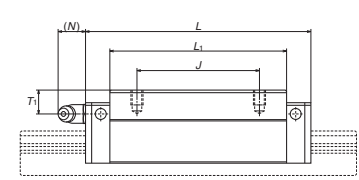

**Reference number for rail of random-matching type**

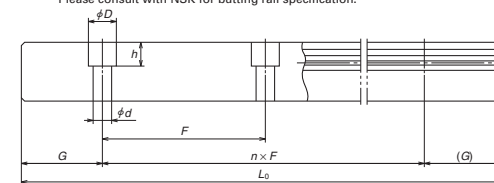
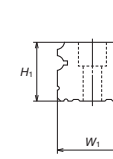
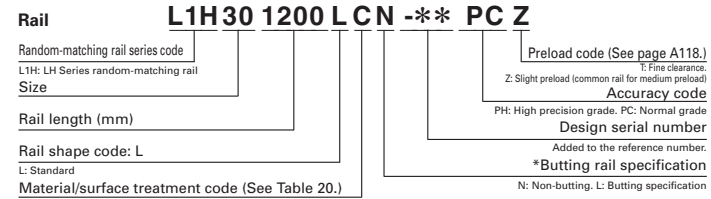

Unit: mm

Rail	Pitch	Mounting bolt hole d × D × h	G	Max. length L <sub>max</sub> ( ) for stainless	Basic load rating						Weight		
					Dynamic		Static	Static moment (N-m)				Ball slide (kg)	Rail (kg/m)
					[50km] C <sub>50</sub> (N)	[100km] C <sub>100</sub> (N)		C <sub>0</sub>	M <sub>RO</sub>	M <sub>PO</sub>			
20	2.4×4.2×2.3	7.5	(375)	1 240	985	2 630	7.25	4.55	32.5	3.8	27.2	0.013	0.31
25	3.5×6×3.5	10	(600)	2 250	1 790	4 500	16.2	10.5	73.0	8.8	61.0	0.026	0.44
40	3.5×6×4.5	15	(800)	5 650	4 500	11 300	47.5	41.5	254	35	214	0.082	0.88
60	4.5×7.5×5.3	20	2 000 (1 800)	10 800 14 600	8 550 11 600	20 700 32 000	108 166	94.5 216	575 1 150	79.5 181	480 965	0.18 0.26	1.6
60	6×9.5×8.5	20	3 960 (3 500)	17 400 23 500	13 800 18 700	32 500 50 500	219 340	185 420	1 140 2 230	155 355	955 1 870	0.33 0.48	2.6
60	7×11×9	20	3 960 (3 500)	25 600 34 500	20 300 27 500	46 000 71 000	360 555	320 725	1 840 3 700	267 610	1 540 3 100	0.55 0.82	3.6
80	9×14×12	20	4 000 (3 500)	31 000 46 000	24 600 36 500	51 500 91 500	490 870	350 1 030	2 290 5 600	292 865	1 920 4 700	0.77 1.3	5.2
80	9×14×12	20	4 000	47 500 61 500	37 500 49 000	80 500 117 000	950 1 380	755 1 530	4 500 8 350	630 1 280	3 800 7 000	1.5 2.1	7.2
105	14×20×17	22.5	3 990	81 000 99 000	64 000 78 500	140 000 187 000	2 140 2 860	1 740 3 000	9 750 15 600	1 460 2 520	8 150 13 100	3.0 3.9	12.3
120	16×23×20	30	3 960	119 000 146 000	94 500 116 000	198 000 264 000	3 600 4 850	3 000 5 150	16 300 26 300	2 510 4 350	13 700 22 100	4.7 6.1	16.9
150	18×26×22	35	3 900	181 000 235 000	144 000 186 000	281 000 410 000	6 150 8 950	4 950 10 100	27 900 51 500	4 150 8 450	23 400 43 500	7.7 10.8	24.3

4) The basic load rating comply with the ISO standard. (ISO 14728-1, 14728-2)  
 C<sub>50</sub>: the basic dynamic load rating for 50 km rated fatigue life C<sub>100</sub>: the basic dynamic load rating for 100 km rated fatigue life  
 5) Random matching is available for LH15 to LH65.  
 6) High-precision grade and medium preload of random-matching type are available for LH15 to LH45 of high-carbon steel products.



LH-AL (High-load type / Standard)  
LH-BL (Super-high-load type / Long)

**LH 30 1200 AL C 2 -\*\* PC Z**

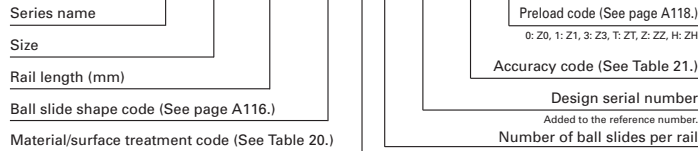

C: Special high carbon steel (NSK standard), K: Stainless steel

Front view of AL and BL types

Side view of AL type

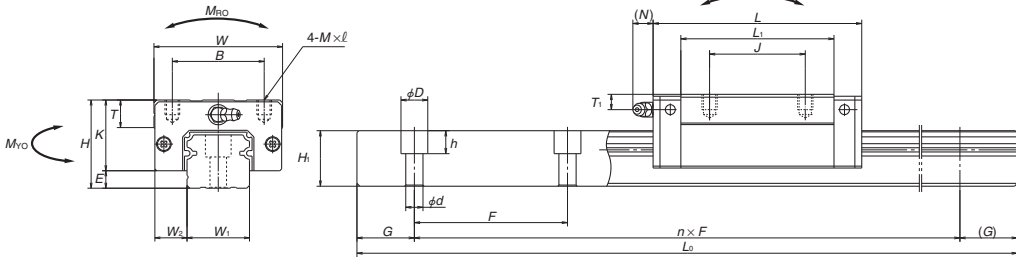

Side view of BL type

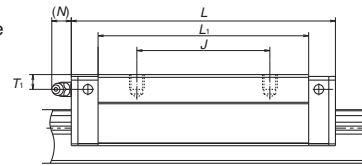

Model No.	Assembly			Ball slide											Width	Height	
	Height	E	W <sub>2</sub>	Width	Length	Mounting hole					Grease fitting			Width			Height
						B	J	M × pitch × l	L <sub>1</sub>	K	T	Hole size	T <sub>1</sub>				
<b>LH25AL</b> <b>LH25BL</b>	36	7	12.5	48	79 107	35 50	M6×1×6	58 86	29	12	M6×0.75	6	11	23	22		
<b>LH30AL</b> <b>LH30BL</b>	42	9	16	60	85.6 124.6	40 60	M8×1.25×8	59 98	33	14	M6×0.75	7	11	28	26		
<b>LH35AL</b> <b>LH35BL</b>	48	9.5	18	70	109 143	50 72	M8×1.25×8	80 114	38.5	15	M6×0.75	8	11	34	29		
<b>LH45AL</b> <b>LH45BL</b>	60	14	20.5	86	139 171	60 80	M10×1.5×10	105 137	46	17	Rc1/8	10	13	45	38		
<b>LH55AL</b> <b>LH55BL</b>	70	15	23.5	100	163 201	75 95	M12×1.75×13	126 164	55	15	Rc1/8	11	13	53	44		

Notes: 1) External appearance of stainless steel ball slides differs from those of carbon steel ball slides.

Reference number for ball slide of random-matching type

Ball slide **LAH 30 AL SZ -K**

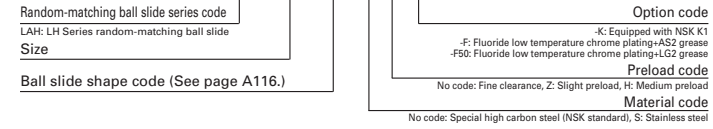

AL and BL types

AL type

BL type

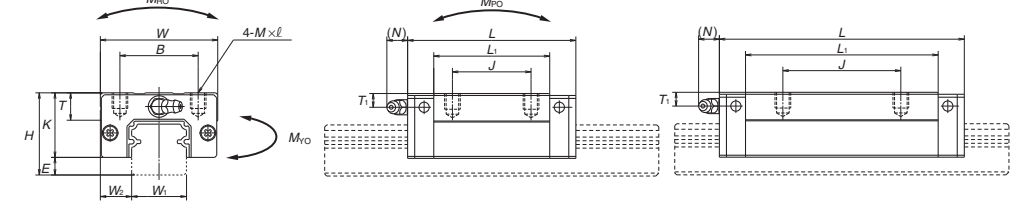

Reference number for rail of random-matching type

Rail **L1H30 1200 LCN -\*\* PC Z**

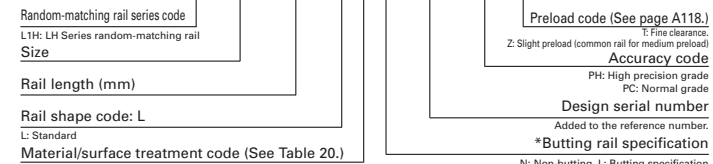

\*Please consult with NSK for butting rail specification.

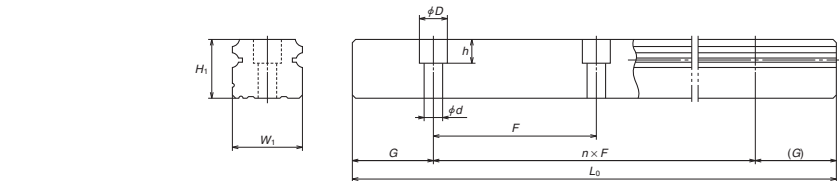

Unit: mm

Rail		Basic load rating								Weight			
Pitch	Mounting bolt hole	G	Max. length L <sub>max</sub> ( ) for stainless	<sup>2)</sup> Dynamic		Static C <sub>0</sub> (N)	Static moment (N-m)				Ball slide (kg)	Rail (kg/m)	
				C <sub>50</sub> (N)	C <sub>100</sub> (N)		M <sub>PC</sub>		M <sub>VO</sub>				
							One slide	Two slides	One slide	Two slides			
60	7×11×9	20	3 960 (3 500)	25 600	20 300	46 000	360	320	1 840	267	1 540	0.46	3.6
				34 500	27 500	71 000	555	725	3 700	610	3 100	0.69	
80	9×14×12	20	4 000 (3 500)	31 000	24 600	51 500	490	350	2 290	292	1 920	0.69	5.2
				46 000	36 500	91 500	870	1 030	5 600	865	4 700	1.16	
80	9×14×12	20	4 000	47 500	37 500	80 500	950	755	4 500	630	3 800	1.2	7.2
				61 500	49 000	117 000	1 380	1 530	8 350	1 280	7 000	1.7	
105	14×20×17	22.5	3 990	81 000	64 000	140 000	2 140	1 740	9 750	1 460	8 150	2.2	12.3
				99 000	78 500	187 000	2 860	3 000	15 600	2 520	13 100	2.9	
120	16×23×20	30	3 960	119 000	94 500	198 000	3 600	3 000	16 300	2 510	13 700	3.7	16.9
				146 000	116 000	264 000	4 850	5 150	26 300	4 350	22 100	4.7	

2) The basic load rating comply with the ISO standard. (ISO 14728-1, 14728-2)

C<sub>50</sub>: the basic dynamic load rating for 50 km rated fatigue life C<sub>100</sub>: the basic dynamic load rating for 100 km rated fatigue life

3) High-precision grade and medium preload of random-matching type are available for LH15 to LH45 of high-carbon steel products.

LH-EM (High-load type / Standard)  
LH-GM (Super-high-load type / Long)

LH 30 1200 EMC 2 -\*\* PC Z

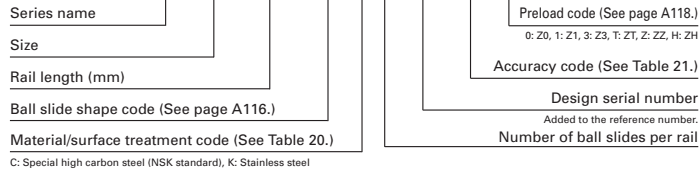

Front view of EM and GM types

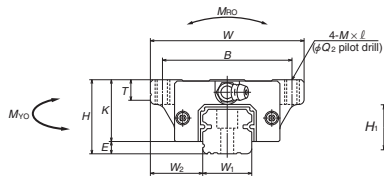

Side view of EM type

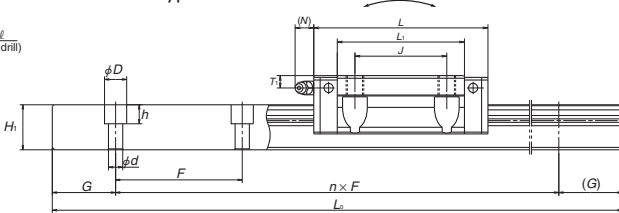

Side view of GM type

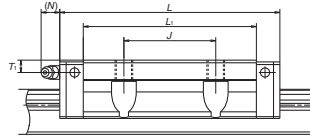

Reference number for ball slide of random-matching type

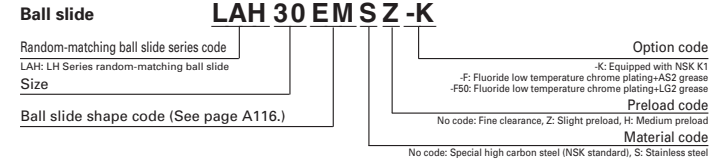

EM and GM types

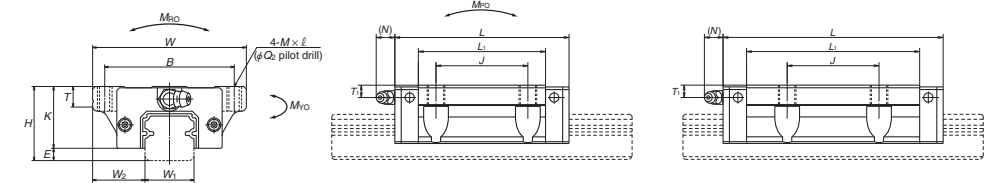

Reference number for rail of random-matching type

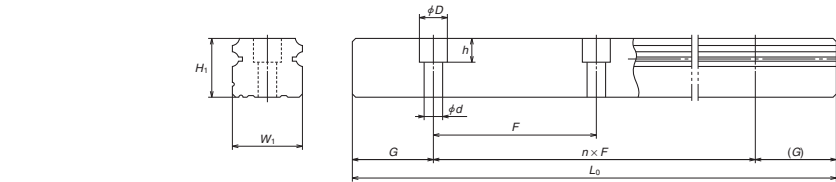
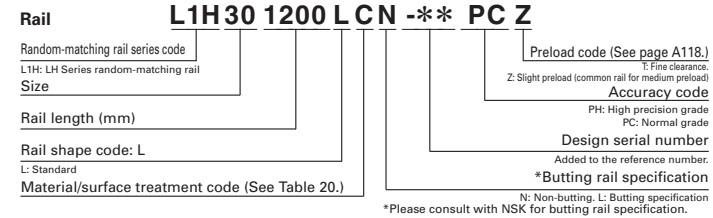

Unit: mm

Model No.	Assembly			Ball slide													Width	Height	
	Height	E	W <sub>2</sub>	W	L	Mounting hole				L <sub>1</sub>	K	T	Grease fitting			W <sub>1</sub>			H <sub>1</sub>
						B	J	M × pitch × ℓ	Q <sub>2</sub>				Hole size	T <sub>1</sub>	N				
LH15EM	24	4.6	16	47	55	38	30	M5×0.8×7	4.4	39	19.4	8	φ 3	4.5	3.3	15	15		
LH15GM					74					58									
LH20EM	30	5	21.5	63	69.8	53	40	M6×1×9.5	5.3	50	25	10	M6×0.75	5	11	20	18		
LH20GM					91.8					72									
LH25EM	36	7	23.5	70	79	57	45	M8×1.25×10	6.8	58	29	11	M6×0.75	6	11	23	22		
LH25GM					107			(M8×1.25×11.5)		86		(12)							
LH30EM	42	9	31	90	98.6	72	52	M10×1.5×12	8.6	72	33	11	M6×0.75	7	11	28	26		
LH30GM					124.6			(M10×1.5×14.5)		98		(15)							
LH35EM	48	9.5	33	100	109	82	62	M10×1.5×13	8.6	80	38.5	12	M6×0.75	8	11	34	29		
LH35GM					143					114									
LH45EM	60	14	37.5	120	139	100	80	M12×1.75×15	10.5	105	46	13	Rc1/8	10	13	45	38		
LH45GM					171					137									
LH55EM	70	15	43.5	140	163	116	95	M14×2×18	12.5	126	55	15	Rc1/8	11	13	53	44		
LH55GM					201					164									
LH65EM	90	16	53.5	170	193	142	110	M16×2×24	14.6	147	74	23	Rc1/8	19	13	63	53		
LH65GM					253					207									

Notes: 1) Parenthesized dimensions are for items made of stainless steel.

2) External appearance of stainless steel ball slides differs from those of carbon steel ball slides.

Rail		Basic load rating										Weight	
Pitch	Mounting bolt hole	G	Max. length L <sub>dimax</sub> ( ) for stainless	Dynamic		C <sub>0</sub>	M <sub>Bo</sub>	Static moment (N·m)				Ball slide	Rail
				[50km]	[100km]			M <sub>Bo</sub>		M <sub>Vo</sub>			
				C <sub>50</sub> (N)	C <sub>100</sub> (N)	(N)	One slide	Two slides	One slide	Two slides	(kg)	(kg/m)	
F	d × D × h	(reference)											
60	4.5×7.5×5.3	20	2 000 (1 800)	10 800	8 550	20 700	108	94.5	575	79.5	480	0.17	1.6
60	6×9.5×8.5	20	3 960 (3 500)	17 400	13 800	32 500	219	185	1 140	155	955	0.45	2.6
60	7×11×9	20	3 960 (3 500)	25 600	20 300	46 000	360	320	1 840	267	1 540	0.63	3.6
80	9×14×12	20	4 000 (3 500)	34 500	27 500	71 000	555	725	3 700	610	3 100	0.93	
80	9×14×12	20	4 000	47 500	37 500	80 500	950	755	4 500	630	3 800	1.7	7.2
105	14×20×17	22.5	3 990	61 500	49 000	117 000	1 380	1 530	8 350	1 280	7 000	2.4	
120	16×23×20	30	3 960	81 000	64 000	140 000	2 140	1 740	9 750	1 460	8 150	3	12.3
150	18×26×22	35	3 900	99 000	78 500	187 000	2 860	3 000	15 600	2 520	13 100	3.9	
				119 000	94 500	198 000	3 600	3 000	16 300	2 510	13 700	5	16.9
				146 000	116 000	264 000	4 850	5 150	26 300	4 350	22 100	6.5	
				181 000	144 000	281 000	6 150	4 950	27 900	4 150	23 400	10	24.3
				235 000	186 000	410 000	8 950	10 100	51 500	8 450	43 500	14.1	

3) The basic load rating comply with the ISO standard. (ISO 14728-1, 14728-2)

C<sub>50</sub>: the basic dynamic load rating for 50 km rated fatigue life C<sub>100</sub>: the basic dynamic load rating for 100 km rated fatigue life

4) High-precision grade and medium preload of random-matching type are available for LH15 to LH45 of high-carbon steel products.

LH-EL (High-load type / Standard)  
LH-GL (Super-high-load type / Long)

LH 30 1200 EL C 2 -\*\* PC Z

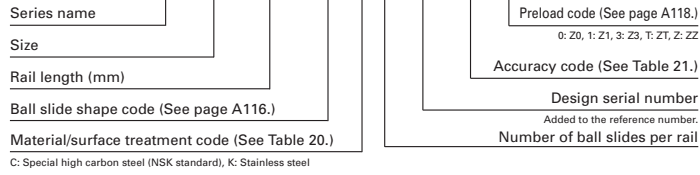

Front view of EL and GL types

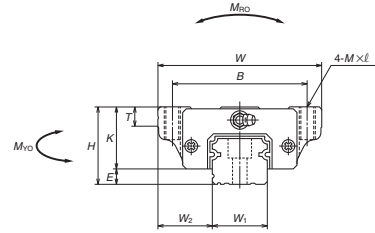

Side view of EL type

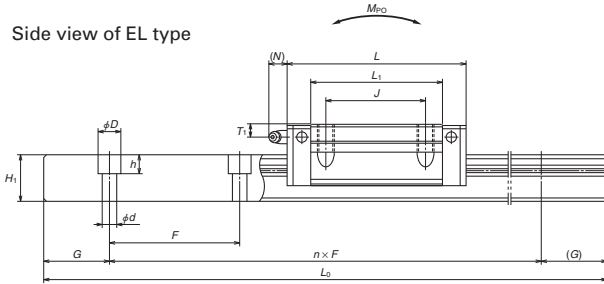

Side view of GL type

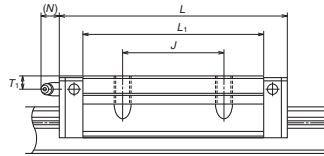

Reference number for ball slide of random-matching type

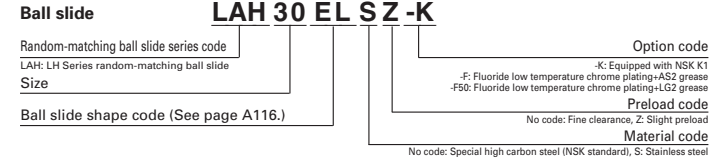

EL and GL types

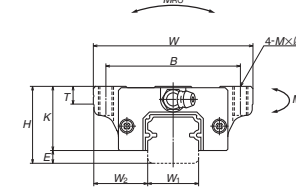

EL type

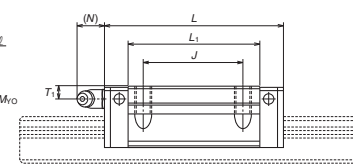

GL type

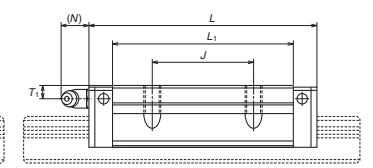

Reference number for rail of random-matching type

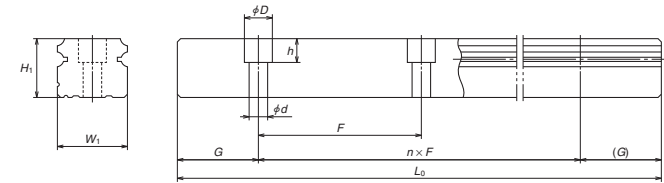
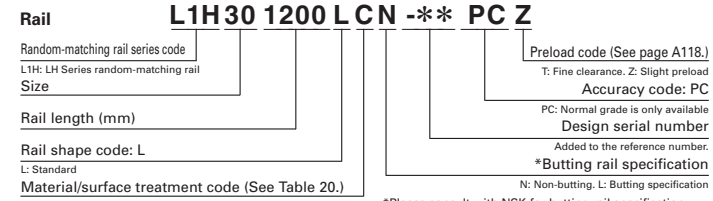

Unit: mm

Model No.	Assembly			Ball slide											Width	Height
	Height	Width	Length	Mounting hole						Grease fitting			Width	Height		
				B	J	M x pitch x l	L1	K	T	Hole size	T1	N				
LH15EL LH15GL	24	4.6	16	47	55 74	38	30	M5x0.8x8	39 58	19.4	8	phi 3	4.5	3.3	15	15
LH20EL LH20GL	30	5	21.5	63	69.8 91.8	53	40	M6x1x10	50 72	25	10	M6x0.75	5	11	20	18
LH25EL LH25GL	36	7	23.5	70	79 107	57	45	M8x1.25x16 (M8x1.25x12)	58 86	29	11 (12)	M6x0.75	6	11	23	22
LH30EL LH30GL	42	9	31	90	98.6 124.6	72	52	M10x1.5x18 (M10x1.5x15)	72 98	33	11 (15)	M6x0.75	7	11	28	26
LH35EL LH35GL	48	9.5	33	100	109 143	82	62	M10x1.5x20	80 114	38.5	12	M6x0.75	8	11	34	29
LH45EL LH45GL	60	14	37.5	120	139 171	100	80	M12x1.75x24	105 137	46	13	Rc1/8	10	13	45	38
LH55EL LH55GL	70	15	43.5	140	163 201	116	95	M14x2x28	126 164	55	15	Rc1/8	11	13	53	44
LH65EL LH65GL	90	16	53.5	170	193 253	142	110	M16x2x24	147 207	74	23	Rc1/8	19	13	63	53

Notes: 1) Parenthesized dimensions are for items made of stainless steel.

2) External appearance of stainless steel ball slides differs from those of carbon steel ball slides.

Rail		Basic load rating										Weight	
Pitch	Mounting bolt hole	G	Max. length L <sub>max</sub> (reference) for stainless	Dynamic		Static	Static moment (N-m)				Ball slide	Rail	
				[50km]	[100km]		M <sub>PO</sub>		M <sub>VO</sub>				
				C <sub>50</sub> (N)	C <sub>100</sub> (N)	C <sub>0</sub>	M <sub>RO</sub>	One slide	Two slides	One slide	Two slides	(kg)	(kg/m)
60	4.5x7.5x5.3	20	2 000 (1 800)	10 800 8 550	14 600 11 600	20 700 32 000	108 166	94.5 216	575 1 150	79.5 181	480 965	0.17 0.25	1.6
60	6x9.5x8.5	20	3 960 (3 500)	17 400 23 500	13 800 18 700	32 500 50 500	219 340	185 420	1 140 2 230	155 355	955 1 870	0.45 0.65	2.6
60	7x11x9	20	3 960 (3 500)	25 600 34 500	20 300 27 500	46 000 71 000	360 555	320 725	1 840 3 700	267 610	1 540 3 100	0.63 0.93	3.6
80	9x14x12	20	4 000 (3 500)	35 500 46 000	28 300 36 500	63 000 91 500	600 870	505 1 030	3 150 5 600	425 865	2 650 4 700	1.2 1.6	5.2
80	9x14x12	20	4 000	47 500 61 500	37 500 49 000	80 500 117 000	950 1 380	755 1 530	4 500 8 350	630 1 280	3 800 7 000	1.7 2.4	7.2
105	14x20x17	22.5	3 990	81 000 99 000	64 000 78 500	140 000 187 000	2 140 2 860	1 740 3 000	9 750 15 600	1 460 2 520	8 150 13 100	3.0 3.9	12.3
120	16x23x20	30	3 960	119 000 146 000	94 500 116 000	198 000 264 000	3 600 4 850	3 000 5 150	16 300 26 300	2 510 4 350	13 700 22 100	5.0 6.5	16.9
150	18x26x22	35	3 900	181 000 235 000	144 000 186 000	281 000 410 000	6 150 8 950	4 950 10 100	27 900 51 500	4 150 8 450	23 400 43 500	10.0 14.1	24.3

3) The basic load rating comply with the ISO standard. (ISO 14728-1, 14728-2)

C<sub>50</sub>: the basic dynamic load rating for 50 km rated fatigue life C<sub>100</sub>: the basic dynamic load rating for 100 km rated fatigue life

4) High-precision grade and medium preload of random-matching type are not available for EL and GL models.

LH-FL (High-load type / Standard)  
LH-HL (Super-high-load type / Long)

LH 30 1200 FL C 2 -\*\* PC Z

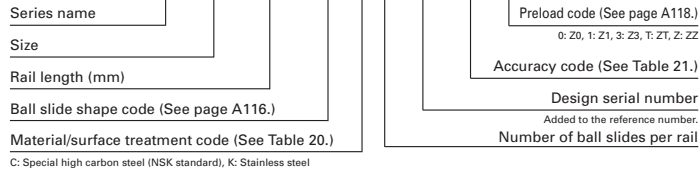

Front view of FL and HL types

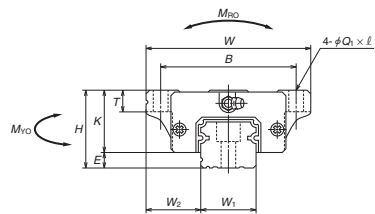

Side view of FL type

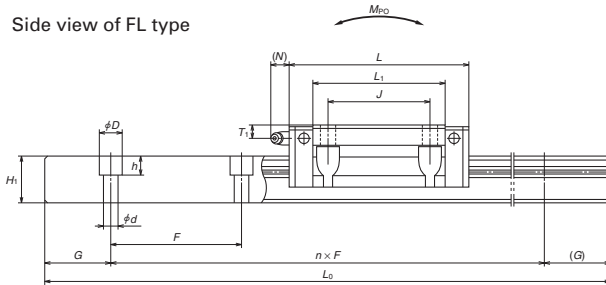

Side view of HL type

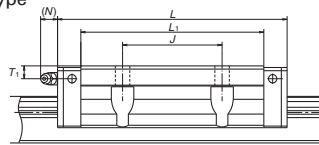

Model No.	Assembly			Ball slide										Width	Height	
	Height	E	W <sub>2</sub>	Width	Length	Mounting hole				Grease fitting		Width	Height			
						B	J	Q <sub>1</sub> × ℓ	L <sub>1</sub>	K	T					Hole size
LH15FL LH15HL	24	4.6	16	47	55 74	38	30	4.5×7	39 58	19.4	8	φ 3	4.5	3.3	15	15
LH20FL LH20HL	30	5	21.5	63	69.8 91.8	53	40	6×9.5	50 72	25	10	M6×0.75	5	11	20	18
LH25FL LH25HL	36	7	23.5	70	79 107	57	45	7×10 (7×11.5)	58 86	29	11 (12)	M6×0.75	6	11	23	22
LH30FL LH30HL	42	9	31	90	98.6 124.6	72	52	9×12 (9×14.5)	72 98	33	11 (15)	M6×0.75	7	11	28	26
LH35FL LH35HL	48	9.5	33	100	109 143	82	62	9×13	80 114	38.5	12	M6×0.75	8	11	34	29
LH45FL LH45HL	60	14	37.5	120	139 171	100	80	11×15	105 137	46	13	Rc1/8	10	13	45	38
LH55FL LH55HL	70	15	43.5	140	163 201	116	95	14×18	126 164	55	15	Rc1/8	11	13	53	44
LH65FL LH65HL	90	16	53.5	170	193 253	142	110	16×24	147 207	74	23	Rc1/8	19	13	63	53

Notes: 1) Parenthesized dimensions are for items made of stainless steel.

2) External appearance of stainless steel ball slides differs from those of carbon steel ball slides.

Reference number for ball slide of random-matching type

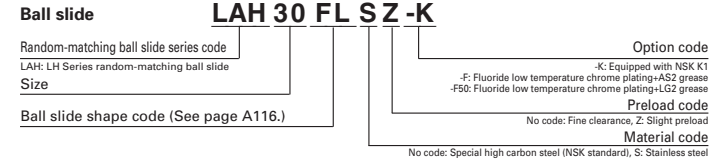

FL and HL types

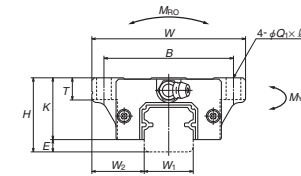

FL type

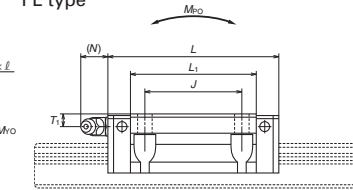

HL type

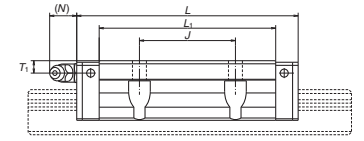

Reference number for rail of random-matching type

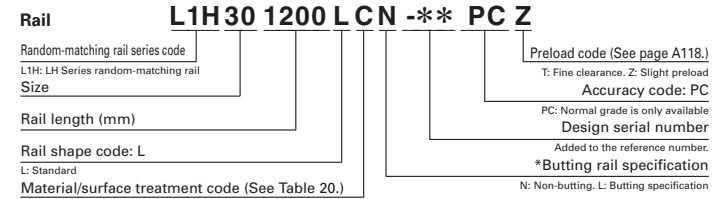

\*Please consult with NSK for butting rail specification.

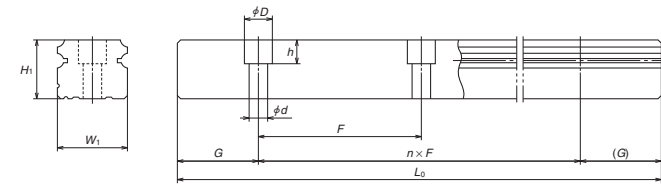

Unit: mm

Rail				Basic load rating						Weight			
Pitch	Mounting bolt hole	G	Max. length L <sub>max</sub> ( ) for stainless	Dynamic		Static C <sub>0</sub> (N)	M <sub>BO</sub>	Static moment (N-m)				Ball slide (kg)	Rail (kg/m)
				[50km] C <sub>50</sub> (N)	[100km] C <sub>100</sub> (N)			M <sub>BO</sub>		M <sub>VO</sub>			
				F	d × D × h	(reference)				One slide	Two slides	One slide	Two slides
60	4.5×7.5×5.3	20	2 000 (1 800)	10 800 14 600	8 550 11 600	20 700 32 000	108 166	94.5 216	575 1 150	79.5 181	480 965	0.17 0.25	1.6
60	6×9.5×8.5	20	3 960 (3 500)	17 400 23 500	13 800 18 700	32 500 50 500	219 340	185 420	1 140 2 230	155 355	955 1 870	0.45 0.65	2.6
60	7×11×9	20	3 960 (3 500)	25 600 34 500	20 300 27 500	46 000 71 000	360 555	320 725	1 840 3 700	267 610	1 540 3 100	0.63 0.93	3.6
80	9×14×12	20	4 000 (3 500)	35 500 46 000	28 300 36 500	63 000 91 500	600 870	505 1 030	3 150 5 600	425 865	2 650 4 700	1.2 1.6	5.2
80	9×14×12	20	4 000	47 500 61 500	37 500 49 000	80 500 117 000	950 1 380	765 1 530	4 500 8 350	630 1 280	3 800 7 000	1.7 2.4	7.2
105	14×20×17	22.5	3 990	81 000 99 000	64 000 78 500	140 000 187 000	2 140 2 860	1 740 3 000	9 750 15 600	1 460 2 520	8 150 13 100	3 3.9	12.3
120	16×23×20	30	3 960	119 000 146 000	94 500 116 000	98 000 264 000	3 600 4 850	3 000 5 150	16 300 26 300	2 510 4 350	13 700 22 100	5 6.5	16.9
150	18×26×22	35	3 900	181 000 235 000	144 000 186 000	281 000 410 000	6 150 8 950	4 950 10 100	27 900 51 500	4 150 8 450	23 400 43 500	10 14.1	24.3

3) The basic load rating comply with the ISO standard. (ISO 14728-1, 14728-2)

C<sub>50</sub>: the basic dynamic load rating for 50 km rated fatigue life C<sub>100</sub>: the basic dynamic load rating for 100 km rated fatigue life

4) High-precision grade and medium preload of random-matching type are not available for FL and HL models.

## A-5-1.5 LS Series

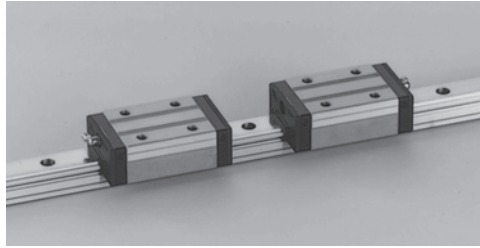

### 1. Features

#### (1) High self aligning capability (rolling direction)

Same as the DF combination in angular contact bearings, self-aligning capability is high because the cross point of the contact lines of balls and grooves comes inside, and thus reducing moment rigidity. This increases the capacity to absorb errors in installation.

#### (2) High load carrying capacity to vertical direction

The contact angle is set at 50 degrees, and thus increasing load carrying capacity as well as rigidity against the load in vertical direction.

#### (3) High resistance against impact load

The bottom ball groove is formed in Gothic arch and the center of the top and bottom grooves are offset as shown in Fig. 2. The vertical load is usually carried by top 2 rows, where balls are contacting at two points. Because of this design, the bottom rows will carry the load when a large impact load is applied as shown in Fig. 3. This assures high resistance to the impact load.

#### (4) High accuracy

As showing in Fig. 4, fixing the measuring rollers to the ball grooves is simple thanks to the Gothic arch groove. This makes easy and accurate measuring of ball grooves.

#### (5) Easy to handle, and designed with safety in mind.

Balls are retained in the retainer and do not fall out when the ball slide is withdrawn from the rail.

#### (6) Abundant models and sizes come in series.

Each size of LS Series has several ball slide models, rendering the linear guide available for numerous uses. The LS Series also has standardized long stainless-steel rail (maximum 3 500 mm).

#### (7) Fast delivery

Lineup of random-matching rails and ball slides supports and facilitates fast delivery.

High precision grade and medium preload types are also available in random matching. (Special high-carbon steel products)

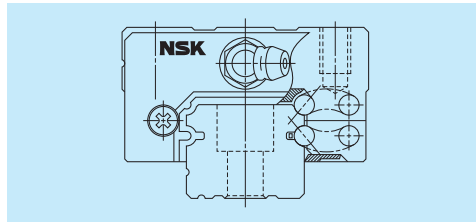

Fig. 1 LS Series

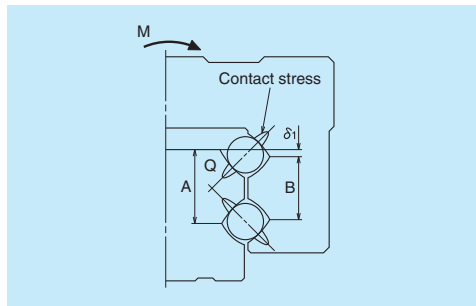

Fig. 2 Enlarged illustration of the offset Gothic arch groove

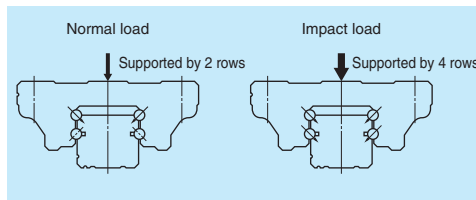

Fig. 3 When load is applied

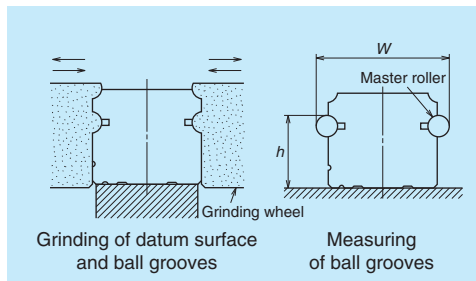

Fig. 4 Rail-grinding and measuring

## 2. Ball slide shape

Ball slide Model	Shape/installation method	Type (Upper row, Rating: Lower row, Ball slide length)	
		Medium-load type	High-load type
		Standard	Long
AL CL		CL 	AL 
EM JM		JM 	EM 
EL JL		JL 	EL 
FL KL		KL 	FL 

Note: High-precision grade and medium preload of random-matching type are not applicable to EL, JL, FL and KL models.

3. Accuracy and preload

(1) Running parallelism of ball slide

Table 1

Unit:  $\mu\text{m}$

Rail length (mm) over   or less	Preloaded assembly (not random matching)					Random-matching type	
	Ultra precision P3	Super precision P4	High precision P5	Precision grade P6	Normal grade PN	High precision PH	Normal grade PC
- 50	2	2	2	4.5	6	2	6
50 - 80	2	2	3	5	6	3	6
80 - 125	2	2	3.5	5.5	6.5	3.5	6.5
125 - 200	2	2	4	6	7	4	7
200 - 250	2	2.5	5	7	8	5	8
250 - 315	2	2.5	5	8	9	5	9
315 - 400	2	3	6	9	11	6	11
400 - 500	2	3	6	10	12	6	12
500 - 630	2	3.5	7	12	14	7	14
630 - 800	2	4.5	8	14	16	8	16
800 - 1 000	2.5	5	9	16	18	9	18
1 000 - 1 250	3	6	10	17	20	10	20
1 250 - 1 600	4	7	11	19	23	11	23
1 600 - 2 000	4.5	8	13	21	26	13	26
2 000 - 2 500	5	10	15	22	29	15	29
2 500 - 3 150	6	11	17	25	32	17	32
3 150 - 4 000	9	16	23	30	34	23	34

(2) Accuracy standard

The preloaded assembly has five accuracy grades; Ultra precision P3, Super precision P4, High precision P5, Precision P6 and Normal PN grades, while the random-matching type has High-precision PH and Normal PC grade.

• Tolerance of preloaded assembly

Table 2

Unit:  $\mu\text{m}$

Characteristics	Accuracy grade	Ultra precision P3	Super precision P4	High precision P5	Precision grade P6	Normal grade PN
Mounting height $H$ Variation of $H$ (All ball slides on a set of rails)		$\pm 10$ 3	$\pm 10$ 5	$\pm 20$ 7	$\pm 40$ 15	$\pm 80$ 25
Mounting width $W_2$ or $W_3$ Variation of $W_2$ or $W_3$ (All ball slides on reference rail)		$\pm 15$ 3	$\pm 15$ 7	$\pm 25$ 10	$\pm 50$ 20	$\pm 100$ 30
Running parallelism of surface C to surface A Running parallelism of surface D to surface B		See Table 1, Fig. 5 and Fig. 6				

• Tolerance of random-matching type

Table 3

Unit:  $\mu\text{m}$

Characteristics	Model No.	High precision grade PH	Normal grade PC
Mounting height $H$		$\pm 20$	$\pm 20$
Variation of mounting height $H$		15① 30②	15① 30②
Mounting width $W_2$ or $W_3$		$\pm 30$	$\pm 30$
Variation of mounting width $W_2$ or $W_3$		20	25
Running parallelism of surface C to surface A Running parallelism of surface D to surface B		See Table 1, Fig. 5 and Fig. 6	

Notes: ① Variation on the same rail  
② Variation on multiple rails

(3) Combinations of accuracy and preload

Table 4

	Accuracy grade							
	Ultra precision	Super precision	High precision	Precision grade	Normal grade	High precision	Normal grade	
Without NSK K1 lubrication unit	P3	P4	P5	P6	PN	PH	PC	
With NSK K1 lubrication unit	K3	K4	K5	K6	KN	KH	KC	
With NSK K1 for food and medical equipment	F3	F4	F5	F6	FN	FH	FC	
Preload	Fine clearance Z0	○	○	○	○	○	—	—
	Slight preload Z1	○	○	○	○	○	—	—
	Medium preload Z3	○	○	○	○	—	—	—
	Random-matching type with fine clearance ZT	—	—	—	—	—	—	○
	Random-matching type with slight preload ZZ	—	—	—	—	—	○	○
	Random-matching type with medium preload ZH	—	—	—	—	—	○	○

(4) Assembled accuracy

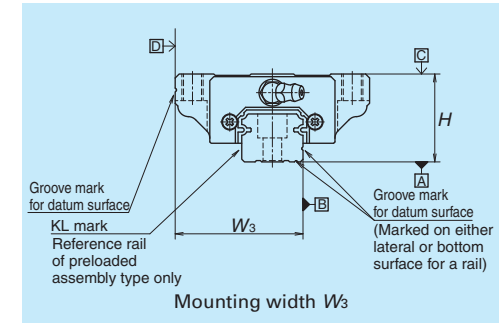
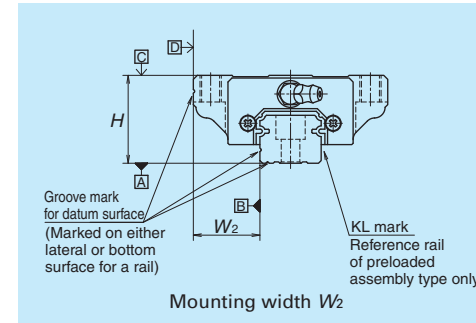

Fig. 5 Special high carbon steel

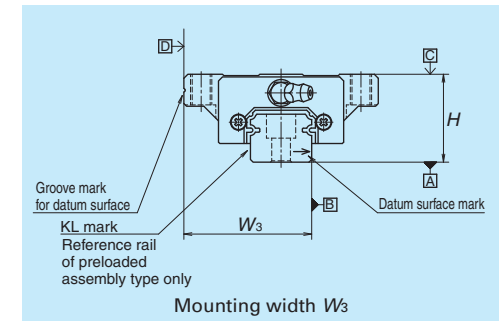
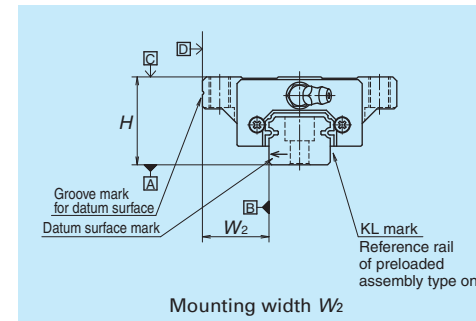

Fig. 6 Stainless steel



**(5) Preload and rigidity**

We offer six levels of preload: Slight preload Z1, Medium preload Z3 and Fine clearance Z0, along with random-matching type of Medium preload ZH, Fine clearance ZT and Slight preload ZZ.

• **Preload and rigidity of preloaded assembly**

**Table 5**

Model No.	Preload (N)		Rigidity (N/μm)			
	Slight preload Z1	Medium preload Z3	Vertical direction		Lateral direction	
			Slight preload Z1	Medium preload Z3	Slight preload Z1	Medium preload Z3
High-load type LS15 AL, EM, EL, FL LS20 AL, EM, EL, FL LS25 AL, EM, EL, FL LS30 AL, EM, EL, FL LS35 AL, EM, EL, FL	69	390	127	226	88	167
	88	540	147	284	108	206
	147	880	206	370	147	275
	245	1 370	255	460	186	345
	345	1 960	305	550	216	400
Medium-load type LS15 CL, JM, JL, KL LS20 CL, JM, JL, KL LS25 CL, JM, JL, KL LS30 CL, JM, JL, KL LS35 CL, JM, JL, KL	49	294	78	147	59	108
	69	390	108	186	78	137
	98	635	127	235	88	177
	147	980	147	275	108	206
	245	1 370	186	335	137	245

Note: Clearance for Fine clearance Z0 is 0 to 3μm. Therefore, preload is zero. However, Z0 of PN grade is 0 to 15μm.

• **Clearance and preload of random-matching type**

**Table 6**

Model No.	Unit: μm		
	Fine clearance ZT	Slight preload ZZ	Medium preload ZH
LS15	-4 — 15	-4 — 0	-6.5 — -2
LS20	-4 — 15	-4 — 0	-7.5 — -3
LS25	-5 — 15	-5 — 0	-9 — -3.5
LS30	-5 — 15	-5 — 0	-10 — -4.5
LS35	-5 — 15	-6 — 0	-12 — -5

Note: Minus sign denotes that a value is an amount of preload (elastic deformation of balls).

**4. Maximum rail length**

**Table 7** shows the limitations of rail length (maximum length). However, the limitations vary by accuracy grade.

**Table 7 Length limitations of rails**

Unit: mm

Series	Material	Size				
		15	20	25	30	35
LS	Special high carbon steel	2 000	3 960	3 960	4 000	4 000
	Stainless steel	1 700	3 500	3 500	3 500	3 500

Note: Rails can be butted if user requirement exceeds the rail length shown in the table. Please consult NSK.

**5. Installation**

**(1) Permissible values of mounting error**

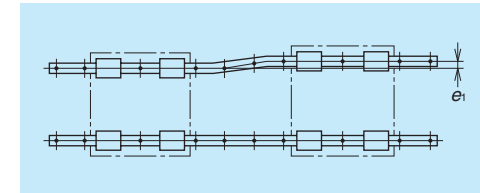

**Fig. 7**

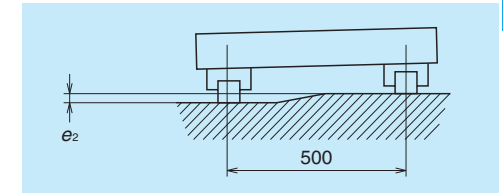

**Fig. 8**

**Table 8**

Unit: μm

Value	Preload	Model No.				
		LS15	LS20	LS25	LS30	LS35
Permissible values of parallelism in two rails e <sub>1</sub>	Z0, ZT	20	22	30	35	40
	Z1, ZZ	15	17	20	25	30
	Z3, ZH	12	15	15	20	25
Permissible values of parallelism (height) in two rails e <sub>2</sub>	Z0, ZT	375 μm/500 mm				
	Z1, ZZ, Z3, ZH	330 μm/500 mm				

**(2) Shoulder height of the mounting surface and corner radius r**

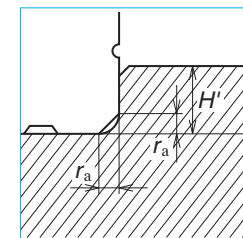

**Fig. 9 Shoulder for the rail datum surface**

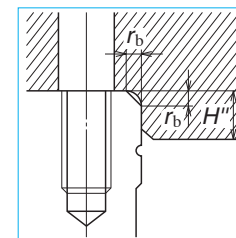

**Fig. 10 Shoulder for the ball slide datum surface**

**Table 9**

Unit: mm

Model No.	Corner radius (maximum)		Shoulder height	
	r <sub>a</sub>	r <sub>b</sub>	H'	H''
LS15	0.5	0.5	4	4
LS20	0.5	0.5	4.5	5
LS25	0.5	0.5	5	5
LS30	0.5	0.5	6	6
LS35	0.5	0.5	6	6

## 6. Lubrication components

Refer to pages A38 and D13 for the lubrication of linear guides.

### (1) Types of lubrication accessories

Fig. 11 and Table 10 show grease fittings and tube fittings.

We provide lubrication accessories with extended thread body length (L) for the addition of dust-proof accessories such as NSK K1 lubrication unit, double seal and protector.

We provide a suitable lubrication accessory for the special requirement on dust-proof accessories.

Consult NSK for a lubrication accessory with extended length of thread body for your convenience of replenishing lubricant.

When you require stainless lubrication accessories, please ask NSK.

### (2) Mounting position of lubrication accessories

The standard position of grease fittings is the end face of ball slide. We mount them on a side of end cap for an option. (Fig. 12)

Please consult NSK for installation of grease or tube fittings to the ball slide body or side of end cap.

When using a piping unit with thread of M6 × 1, you require a connector to connect to a grease fitting mounting hole with M6 × 0.75. The connector is available from NSK.

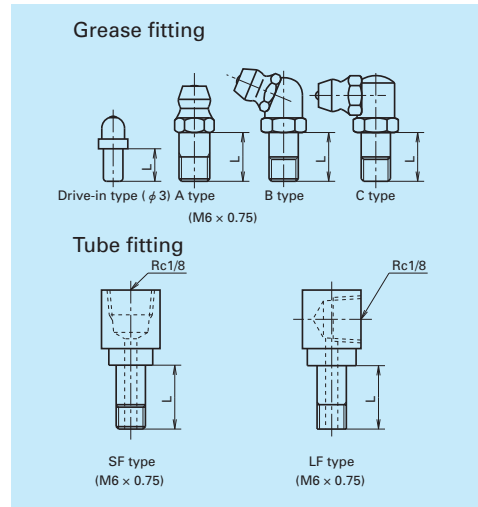

Fig. 11 Grease fitting and tube fitting

Model No.	Dust-proof specification	Grease fitting	Tube fitting
		Thread body length L	Thread body length L
LS15	Standard	5	-
	With NSK K1	10	-
	Double seal	*	-
	Protector	*	-
LS20	Standard	5	-
	With NSK K1	10	-
	Double seal	8	-
	Protector	8	-
LS25	Standard	5	6
	With NSK K1	12	11
	Double seal	10	9
	Protector	10	9
LS30	Standard	5	6
	With NSK K1	14	13
	Double seal	12	11
	Protector	12	11
LS35	Standard	5	6
	With NSK K1	14	13
	Double seal	12	11
	Protector	12	11

\*) A connector is required for this model. Please contact NSK for grease fittings.

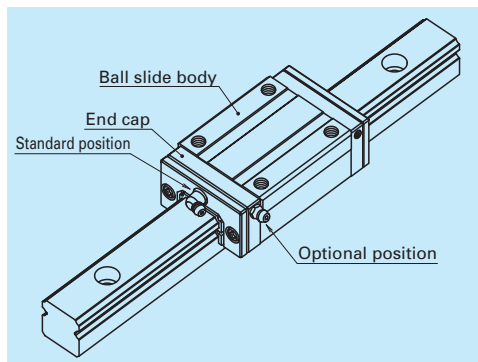

Fig. 12 Mounting position of lubrication accessories

## 7. Dust-proof components

### (1) Standard specification

The LS Series can be readily used as they have a dust protection means for normal conditions. As the standard equipment, the ball slides have an end seal on both ends, and bottom seals at the bottom.

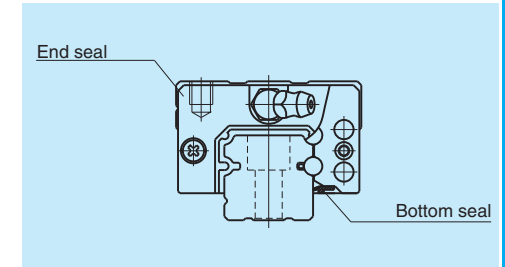

Fig. 13

Table 11 Seal friction per ball slide (maximum value)

Series	Size	Unit: N				
		15	20	25	30	35
LS		8	9	9	9	10

### (2) NSK K1™ lubrication unit

Table 12 shows the dimension of linear guides equipped with the NSK K1 lubrication unit.

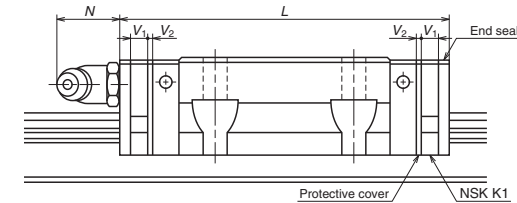

Table 12

Model No.	Ball slide length	Ball slide model	Standard ball slide length	Ball slide length installed with two NSK K1 L	Per NSK K1 thickness V <sub>1</sub>	Protective cover thickness V <sub>2</sub>	Protruding area of the grease fitting N
LS15	Standard	AL, EM, EL, FL	56.8	66.4	4.0	0.8	(5)
	Short	CL, JM, JL, KL	40.4	50			
LS20	Standard	AL, EM, EL, FL	65.2	75.8	4.5	0.8	(14)
	Short	CL, JM, JL, KL	47.2	57.8			
LS25	Standard	AL, EM, EL, FL	81.6	92.2	4.5	0.8	(14)
	Short	CL, JM, JL, KL	59.6	70.2			
LS30	Standard	AL, EM, EL, FL	96.4	108.4	5.0	1.0	(14)
	Short	CL, JM, JL, KL	67.4	79.4			
LS35	Standard	AL, EM, EL, FL	108	121	5.5	1.0	(14)
	Short	CL, JM, JL, KL	77	90			

Note: Ball slide length equipped with NSK K1 = (Standard ball slide length) + (Thickness of NSK K1, V<sub>1</sub> × Number of NSK K1) + (Thickness of the protective cover, V<sub>2</sub> × 2)

**(3) Double seal**

Use a double seal set as showing in **Table 13**, when installing an extra seal to completed standard products. (**Fig. 14**)

When installing a grease fitting after the installation of double seals, a connector as showing **Fig.14** is required.

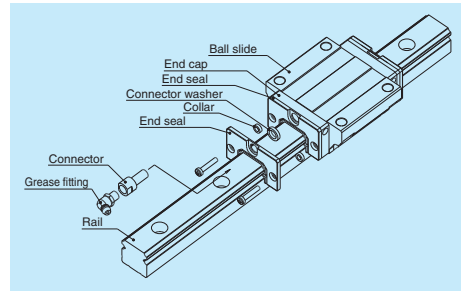
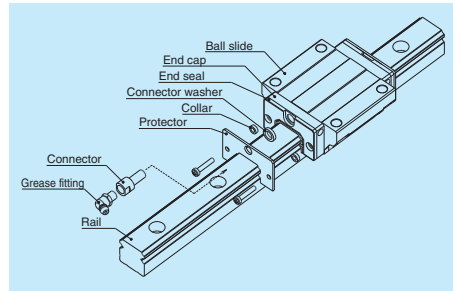

**Fig. 14 Double seal**

**(4) Protector**

Use a protector set as showing **Table 14**, when installing a protector to completed standard products. (**Fig.15**)

When installing a grease fitting after the installation of protectors, a connector as showing **Fig.15** is required.



**Fig. 15 Protector**

**Table 13 Double-seal set**

Model No.	Reference No.		Increased thickness $V_3$ (mm)
	Without connector	With connector	
LS15	LS15WS-01	*	2.8
LS20	LS20WS-01	LS20WSC-01	2.5
LS25	LS25WS-01	LS25WSC-01	2.8
LS30	LS30WS-01	LS30WSC-01	3.6
LS35	LS35WS-01	LS35WSC-01	3.6

**Table 14 Protector set**

Model No.	Reference No.		Increased thickness $V_4$ (mm)
	Without connector	With connector	
LS15	LS15PT-01	*	3
LS20	LS20PT-01	LS20PTC-01	2.7
LS25	LS25PT-01	LS25PTC-01	3.2
LS30	LS30PT-01	LS30PTC-01	4.2
LS35	LS35PT-01	LS35PTC-01	4.2

\*) For installation of a connector to a drive-in type grease fitting, contact NSK.

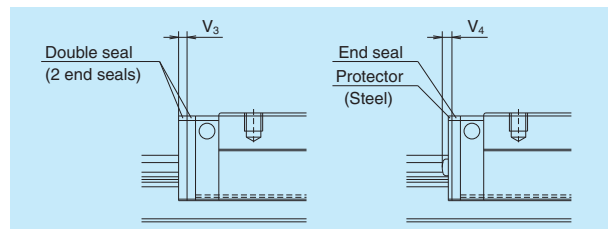

**Fig. 16**

**(5) Cap to plug the rail mounting bolt hole**

**Table 15 Caps to plug rail bolt hole**

Model No.	Bolt to secure rail	Cap reference No.	Quantity /case
LS15	M3	LG-CAP/M3	20
LS15	M4	LG-CAP/M4	20
LS20	M5	LG-CAP/M5	20
LS25, LS30	M6	LG-CAP/M6	20
LS35	M8	LG-CAP/M8	20

**(7) Bellows**

• A bellows fastener kit, which includes one of bellows faster, two of  $M_1$  set screws, two of  $M_2$  set screws, and two collars for  $M_2$  set screws as showing Fig. 7.7 on page A55, is supplied with bellows for the ends.

• Middle bellows are supplied with four set screws and four collars.

Use a bellows fastener kit as showing **Table 17**, when installing bellows to completed standard products.

• When NSK K1, double seals or protectors are used, the set screws of bellows fastener kit are unable to use.

Please contact NSK for details.

• Bellows fastener is available only for the horizontal mounting positions. For other mounting positions, sliding plate is required (see **Fig. 7.10** on page A56).

For fixing to the rail, make tap holes to the rail end surface. Fix the bellows mounting plate to the rail end surface through these tap holes by using a machine screw. NSK processes a tap hole to the rail end face when ordered with a linear guide.

**(6) Inner seal**

Inner seal is only available for the models shown below.

**Table 16**

Series	Model No.
LS	LS20, LS25, LS30, LS35

**Table 17 Bellows fastener kit reference No.**

Model No.	Kit reference No.
LS15	LS15FS-01
LS20	LS20FS-01
LS25	LS25FS-01
LS30	LS30FS-01
LS35	LS35FS-01

Dimension tables of bellows  
LS Series

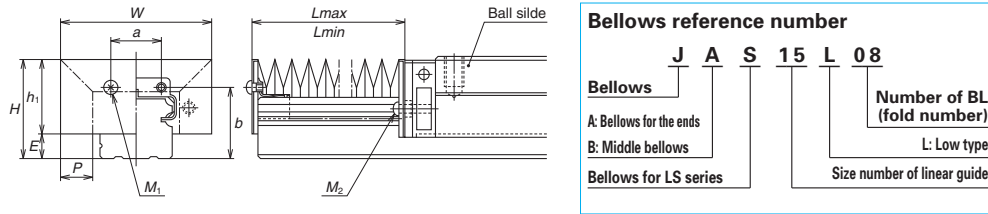

Fig. 17 Dimensions of bellows

Table 18 Dimensions of bellows

Unit: mm

Model No.	H	h <sub>1</sub>	E	W	P	a	b	BL minimum length	M <sub>1</sub> Tap x depth	M <sub>2</sub> Tap x depth
JAS15L	23.5	18.9	4.6	43	10	8	16.5	17	M3 × 5	M3 × 14
JAS20L	27	21	6	48	10	13	19.7	17	M3 × 5	M2.5 × 14
JAS25L	32	25	7	51	10	15	23.2	17	M3 × 5	M3 × 18
JAS30L	41	32	9	66	15	16	29	17	M4 × 6	M4 × 19
JAS35L	47	36.5	10.5	72	15	22	33.5	17	M4 × 6	M4 × 22

Table 19 Numbers of folds (BL) and lengths of bellows

Unit: mm

Model No.	Number of BL	2	4	6	8	10	12	14	16	18	20
		L <sub>min</sub>	34	68	102	136	170	204	238	272	306
JAS15L	Stroke	106	212	318	424	530	636	742	848	954	1 060
	L <sub>max</sub>	140	280	420	560	700	840	980	1 120	1 260	1 400
JAS20L	Stroke	106	212	318	424	530	636	742	848	954	1 060
	L <sub>max</sub>	140	280	420	560	700	840	980	1 120	1 260	1 400
JAS25L	Stroke	106	212	318	424	530	636	742	848	954	1 060
	L <sub>max</sub>	140	280	420	560	700	840	980	1 120	1 260	1 400
JAS30L	Stroke	176	352	528	704	880	1 056	1 232	1 408	1 584	1 760
	L <sub>max</sub>	210	420	630	840	1 050	1 260	1 470	1 680	1 890	2 100
JAS35L	Stroke	176	352	528	704	880	1 056	1 232	1 408	1 584	1 760
	L <sub>max</sub>	210	420	630	840	1 050	1 260	1 470	1 680	1 890	2 100

Note: The values of an odd number BL quantity (3, 5, 7, ...) can be obtained by adding two values of even number BL on the both side, then by dividing the sum by 2.

### 8. Reference number

Reference numbers shall be set to individual NSK linear guide when its specifications are finalized, and it is indicated on its specification drawing.

Please specify the reference number, except design serial number, to identify the product when ordering, requiring estimates, or inquiring about specifications from NSK.

#### (1) Reference number for preloaded assembly

LS 30 1200 AL C 2 -\*\* P5 3

Series name	Size	Rail length (mm)	Ball slide shape code (See page A192.)	Material/surface treatment code (See Table 20.) <small>C: Special high carbon steel (NSK standard), K: Stainless steel</small>	Preload code (See page A194.) <small>0: Z0, 1: Z1, 3: Z3</small>	Accuracy code (See Table 21.)	Design serial number <small>Added to the reference number.</small>	Number of ball slides per rail
-------------	------	------------------	--	---	---	-------------------------------	---	--------------------------------

#### (2) Reference number for random-matching type

LAS 30 ALSZ -K

Random-matching ball slide series code <small>LAS: LS Series random-matching ball slide</small>	Size	Ball slide shape code (See page A192.)	Option code <small>-K: Equipped with NSK K1 -F: Fluoride low temperature chrome plating + AS2 grease -F50: Fluoride low temperature chrome plating + LG2 grease</small>	Preload code <small>No code: Fine clearance, Z: Slight preload, H: Medium preload</small>	Material code <small>No code: Special high carbon steel (NSK standard), S: Stainless steel</small>
--	------	--	--	--	---

L1S30 1200 LCN -\*\* PC Z

Random-matching rail series code <small>L1S: LS Series random-matching rail</small>	Size	Rail length (mm)	Rail shape code <small>L: Standard T: LS15 with mounting holes for M4</small>	Material/surface treatment code (See Table 20.)	Preload code (See page A194.) <small>T: Fine clearance, Z: Slight preload (common rail for slight or medium preload)</small>	Accuracy code <small>PH: High precision grade random-matching type PC: Normal grade random-matching type</small>	Design serial number <small>Added to the reference number.</small>	*Butting rail specification <small>N: Non-butting, L: Butting specification</small>
--	------	------------------	--	---	---	---	---	--

\*Please consult with NSK for butting rail specification.

The reference number coding for the assembly of random-matching type is the same as that of the preloaded assembly. However, only preload codes of "fine clearance T" and "slight preload Z" are available (refer to page A194).

**Table 20 Material/surface treatment code**

Code	Description
C	Special high carbon steel (NSK standard)
K	Stainless steel
D	Special high carbon steel with surface treatment
H	Stainless steel with surface treatment
Z	Other, special

Note: High-precision grade and medium preload of random-matching type are not available in stainless steel.

**Table 21 Accuracy code**

Accuracy	Standard (Without NSK K1)	With NSK K1	With NSK K1 for food and medical equipment
Ultra precision grade	P3	K3	F3
Super precision grade	P4	K4	F4
High precision grade	P5	K5	F5
Precision grade	P6	K6	F6
Normal grade	PN	KN	FN
High precision grade (random-matching type)	PH	KH	FH
Normal grade (random-matching type)	PC	KC	FC

Note: Refer to pages A38 and A61 for NSK K1 lubrication unit.

**9. Dimensions**  
**LS-CL (Medium-load type / Short)**  
**LS-AL (High-load type / Standard)**

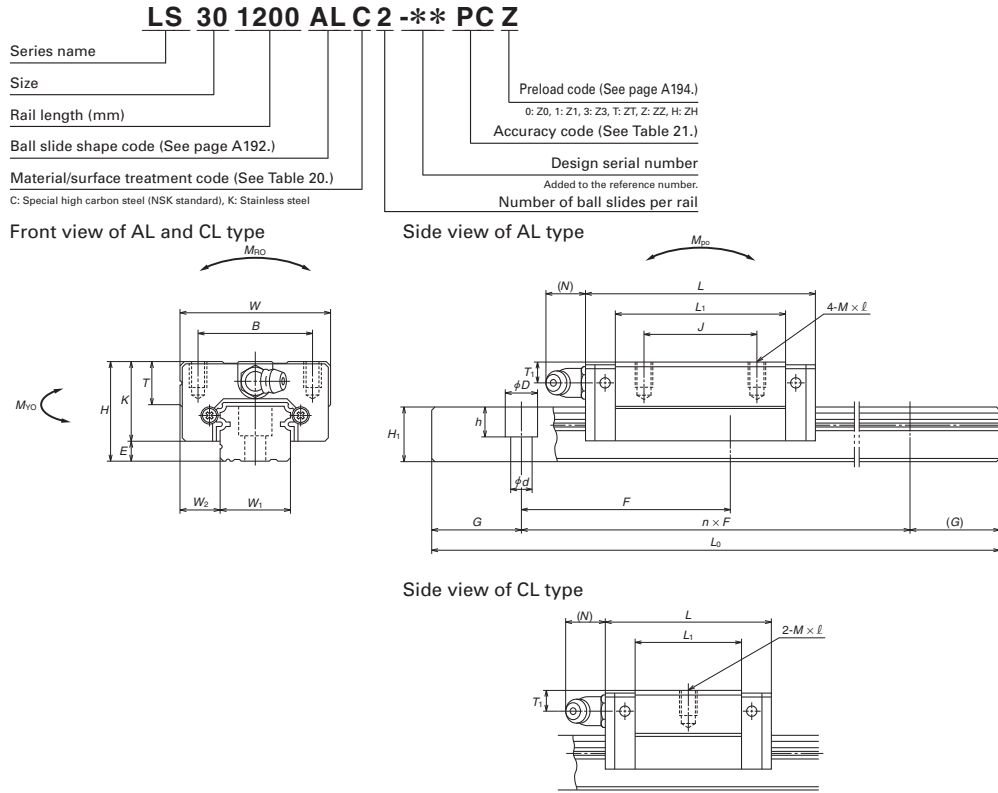

Model No.	Assembly			Ball slide											Width	Height		
	Height	Width	Length	Mounting hole						Grease fitting								
				H	E	W <sub>2</sub>	W	L	B	J	M × pitch × l	L <sub>1</sub>	K	T			Hole size	T <sub>1</sub>
LS15CL	24	4.6	9.5	34	40.4	26	—	M4×0.7×6	23.6	19.4	10	φ 3	6	3	15	12.5		
LS15AL	24	4.6	9.5	34	56.8	26	—	M4×0.7×6	40	19.4	10	φ 3	6	3	15	12.5		
LS20CL	28	6	11	42	47.2	32	—	M5×0.8×7	30	22	12	M6×0.75	5.5	11	20	15.5		
LS20AL	28	6	11	42	65.2	32	—	M5×0.8×7	48	22	12	M6×0.75	5.5	11	20	15.5		
LS25CL	33	7	12.5	48	59.6	35	—	M6×1×9	38	26	12	M6×0.75	7	11	23	18		
LS25AL	33	7	12.5	48	81.6	35	—	M6×1×9	60	26	12	M6×0.75	7	11	23	18		
LS30CL	42	9	16	60	67.4	40	—	M8×1.25×12	42	33	13	M6×0.75	8	11	28	23		
LS30AL	42	9	16	60	96.4	40	—	M8×1.25×12	71	33	13	M6×0.75	8	11	28	23		
LS35CL	48	10.5	18	70	77	50	—	M8×1.25×12	49	37.5	14	M6×0.75	8.5	11	34	27.5		
LS35AL	48	10.5	18	70	108	50	—	M8×1.25×12	80	37.5	14	M6×0.75	8.5	11	34	27.5		

Notes: 1) External appearance of stainless steel ball slides differs from those of carbon steel ball slides.

**Reference number for ball slide of random-matching type**

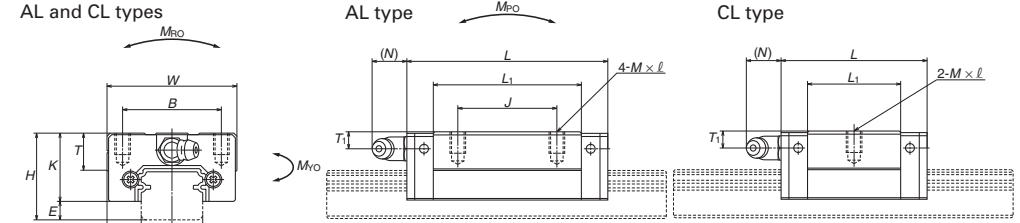
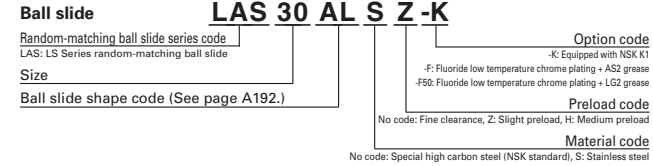

**Reference number for rail of random-matching type**

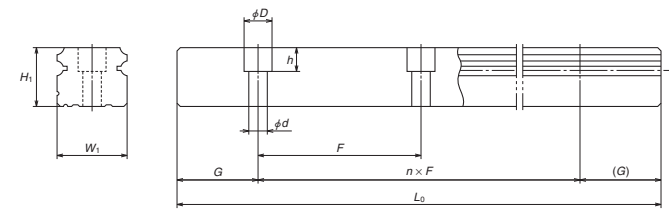
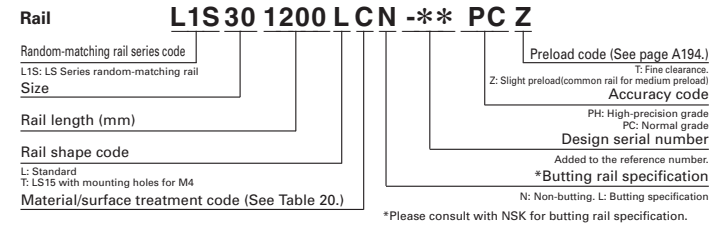

Rail	Basic load rating											Weight	
	Pitch	Mounting bolt hole	G	Max. length L <sub>0max</sub> ( ) for stainless	Dynamic		Static	Static moment (N-m)				Ball slide	Rail
					[50km]	[100km]		C <sub>0</sub>	M <sub>PO</sub>	M <sub>VO</sub>			
60	*3.5×6×4.5 4.5×7.5×5.3	20	2 000 (1 700)	5 400 8 350	4 300 6 600	9 100 16 900	45.5 84.5	24.5 77	196 470	20.5 64.5	165 395	0.14 0.20	1.4
60	6×9.5×8.5	20	3 960 (3 500)	7 900 11 700	6 250 9 250	13 400 23 500	91.5 160	46.5 133	330 755	39 111	279 630	0.19 0.28	2.3
60	7×11×9	20	3 960 (3 500)	12 700 18 800	10 100 14 900	20 800 36 500	164 286	91 258	655 1 470	76 217	550 1 230	0.34 0.51	3.1
80	7×11×9	20	4 000 (3 500)	18 700 28 800	14 800 22 900	29 600 55 000	282 520	139 435	1 080 2 650	116 365	905 2 220	0.58 0.85	4.8
80	9×14×12	20	4 000 (3 500)	26 000 40 000	20 600 31 500	40 000 74 500	465 865	220 695	1 670 4 000	185 580	1 400 3 350	0.86 1.3	7.0

2) The basic load rating comply with the ISO standard. (ISO 14728-1, 14728-2)  
 C<sub>50</sub>: the basic dynamic load rating for 50 km rated fatigue life C<sub>100</sub>: the basic dynamic load rating for 100 km rated fatigue life  
 3) High-precision grade and medium preload of random-matching type are available for special high carbon steel products.  
 \* Standard mounting hole of LS15 rail is for M3 bolts (Hole size: 3.5 × 6 × 4.5).  
 If you require mounting hole for M4 bolts (Hole size: 4.5 × 7.5 × 5.3), please specify when ordering.



LS-JM (Medium-load type / Short)  
LS-EM (High-load type / Standard)

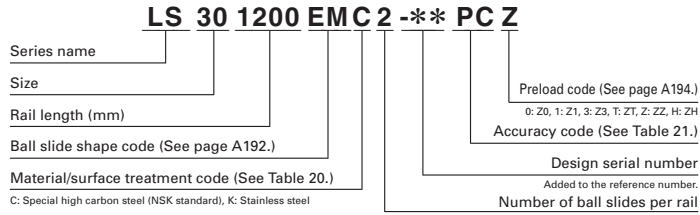

Front view of EM and JM type

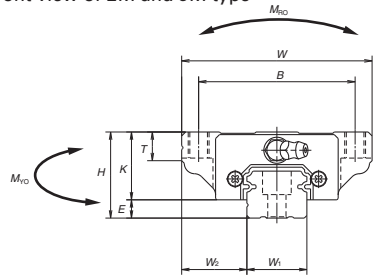

Side view of EM type

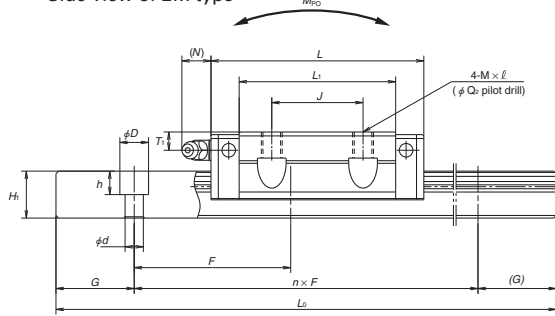

Side view of JM type

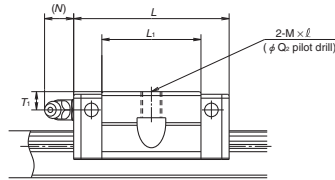

Reference number for ball slide of random-matching type

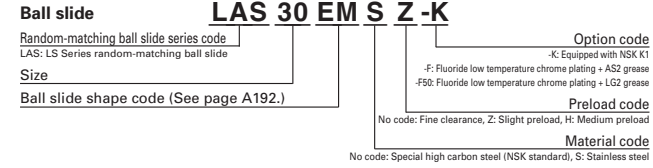

EM and JM types

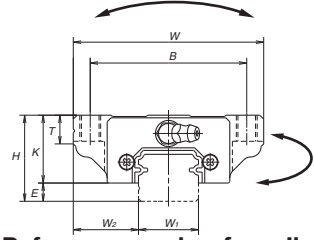

EM type

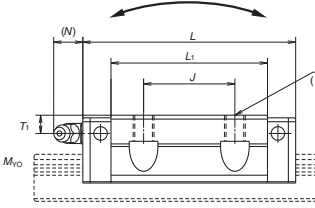

JM type

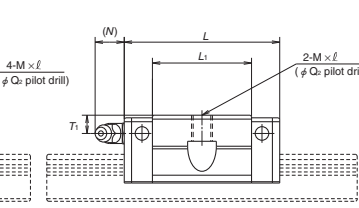

Reference number for rail of random-matching type

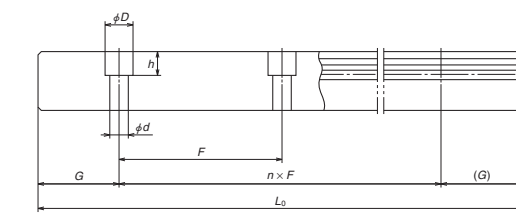
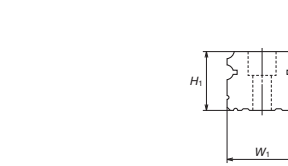
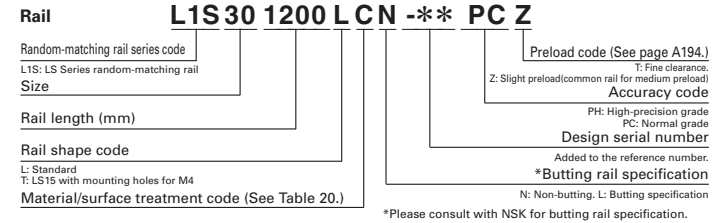

Model No.	Assembly			Ball slide											Width	Height	
	Height	E	W <sub>2</sub>	Width	Length	Mounting hole					Grease fitting			Width			Height
						B	J	M × pitch × l	Q <sub>2</sub>	L <sub>1</sub>	K	T	Hole size				
LS15JM LS15EM	24	4.6	18.5	52	40.4 56.8	41	— 26	M5×0.8×7	4.4	23.6 40	19.4	8	φ3	6	3	15	12.5
LS20JM LS20EM	28	6	19.5	59	47.2 65.2	49	— 32	M6×1×9 (M6×1×9.5)	5.3	30 48	22	10	M6×0.75	5.5	11	20	15.5
LS25JM LS25EM	33	7	25	73	59.6 81.6	60	— 35	M8×1.25×10 (M8×1.25×11.5)	6.8	38 60	26	11 (12)	M6×0.75	7	11	23	18
LS30JM LS30EM	42	9	31	90	67.4 96.4	72	— 40	M10×1.5×12 (M10×1.5×14.5)	8.6	42 71	33	11 (15)	M6×0.75	8	11	28	23
LS35JM LS35EM	48	10.5	33	100	77 108	82	— 50	M10×1.5×13 (M10×1.5×14.5)	8.6	49 80	37.5	12 (15)	M6×0.75	8.5	11	34	27.5

Notes: 1) External appearance of stainless steel ball slides differs from those of carbon steel ball slides.  
 2) Parenthesized dimensions are for items made of stainless steel.

Unit: mm

Rail	Pitch	Mounting bolt hole	G	Max. length L <sub>dimax</sub> ( ) for stainless	Basic load rating				Ball slide	Rail			
					Dynamic		Static	Static moment (N·m)			Ball slide (kg)	Rail (kg/m)	
					[50km]	[100km]		C <sub>0</sub>					M <sub>PO</sub>
60	*3.5×6×4.5 4.5×7.5×5.3	20	2 000 (1 700)	5 400 8 350	4 300 6 600	9 100 16 900	45.5 84.5	24.5 77	196 470	20.5 64.5	165 395	0.17 0.26	1.4
60	6×9.5×8.5	20	3 960 (3 500)	7 900 11 700	6 250 9 250	13 400 23 500	91.5 160	46.5 75.5	330 755	39 111	279 630	0.24 0.35	2.3
60	7×11×9	20	3 960 (3 500)	12 700 18 800	10 100 14 900	20 800 36 500	164 286	91 258	655 1 470	76 217	550 1 230	0.44 0.66	3.1
80	7×11×9	20	4 000 (3 500)	18 700 28 800	14 800 22 900	29 600 55 000	282 520	139 435	1 080 2 650	116 365	905 2 220	0.76 1.2	4.8
80	9×14×12	20	4 000 (3 500)	26 000 40 000	20 600 31 500	40 000 74 500	465 865	220 695	1 670 4 000	185 580	1 400 3 350	1.2 1.7	7

3) The basic load rating comply with the ISO standard. (ISO 14728-1, 14728-2)  
 C<sub>50</sub>: the basic dynamic load rating for 50 km rated fatigue life C<sub>100</sub>: the basic dynamic load rating for 100 km rated fatigue life  
 4) High-precision grade and medium preload of random-matching type are available for special high carbon steel products.  
 \* Standard mounting hole of LS15 rail is for M3 bolts (Hole size: 3.5 × 6 × 4.5).  
 If you require mounting hole for M4 bolts (Hole size: 4.5 × 7.5 × 5.3), please specify when ordering.

LS-JL (Medium-load type / Short)  
LS-EL (High-load type / Standard)

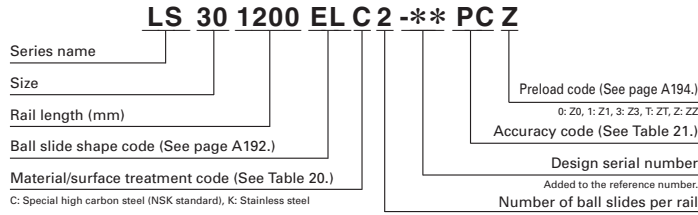

Front view of EL and JL type

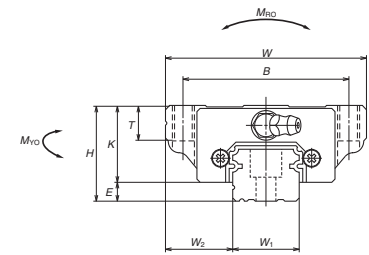

Side view of EL type

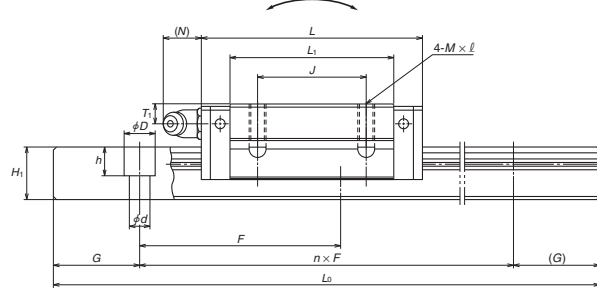

Side view of JL type

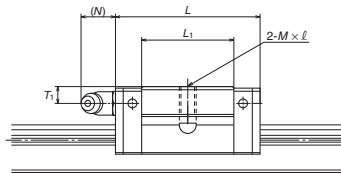

Reference number for ball slide of random-matching type

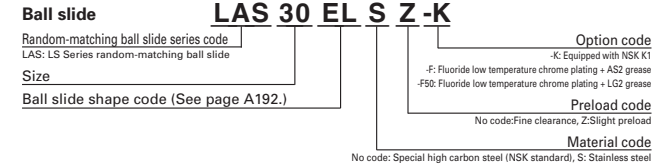

EL and JL types

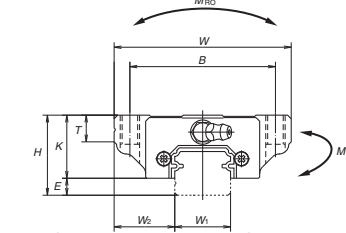

EL type

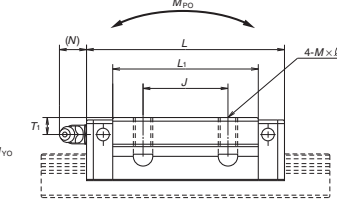

JL type

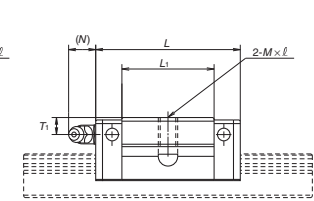

Reference number for rail of random-matching type

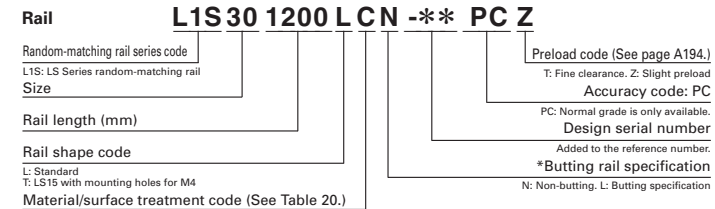

\*Please consult with NSK for butting rail specification.

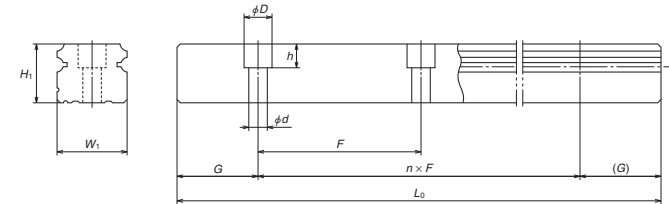

Model No.	Assembly			Ball slide											Width	Height
	Height	Width	Length	Mounting hole						Grease fitting						
				B	J	M × pitch × l	L <sub>1</sub>	K	T	Hole size	T <sub>1</sub>	N	W <sub>1</sub>	H <sub>1</sub>		
LS15JL LS15EL	24	4.6	18.5	52	40.4 56.8	41	— 26	M5×0.8×8	23.6 40	19.4	8	φ 3	6	3	15	12.5
LS20JL LS20EL	28	6	19.5	59	47.2 65.2	49	— 32	M6×1×10	30 48	22	10	M6×0.75	5.5	11	20	15.5
LS25JL LS25EL	33	7	25	73	59.6 81.6	60	— 35	M8×1.25×12	38 60	26	11 (12)	M6×0.75	7	11	23	18
LS30JL LS30EL	42	9	31	90	67.4 96.4	72	— 40	M10×1.5×18 (M10×1.5×15)	42 71	33	11 (15)	M6×0.75	8	11	28	23
LS35JL LS35EL	48	10.5	33	100	77 108	82	— 50	M10×1.5×20 (M10×1.5×15)	49 80	37.5	12 (15)	M6×0.75	8.5	11	34	27.5

Notes: 1) External appearance of stainless steel ball slides differs from those of carbon steel ball slides.  
 2) Parenthesized dimensions are for items made of stainless steel.

Unit: mm

Rail	Basic load rating											Weight	
	Pitch	Mounting bolt hole	G	Max. length L <sub>dimax</sub> ( ) for stainless	Dynamic		Static C <sub>0</sub> (N)	Static moment (N-m)				Ball slide (kg)	Rail (kg/m)
					[50km]	[100km]		M <sub>ro</sub>		M <sub>yo</sub>			
60	*3.5×6×4.5 4.5×7.5×5.3	20	2 000 (1 700)	5 400 8 350	4 300 6 600	9 100 16 900	45.5 84.5	24.5 77	196 470	20.5 64.5	165 395	0.17 0.26	1.4
60	6×9.5×8.5	20	3 960 (3 500)	7 900 11 700	6 250 9 250	13 400 23 500	91.5 160	46.5 133	330 755	39 111	279 630	0.24 0.35	2.3
60	7×11×9	20	3 960 (3 500)	12 700 18 800	10 100 14 900	20 800 36 500	164 286	91 258	655 1 470	76 217	550 1 230	0.44 0.66	3.1
80	7×11×9	20	4 000 (3 500)	18 700 28 800	14 800 22 900	29 600 55 000	282 520	139 435	1 080 2 650	116 365	905 2 220	0.76 1.2	4.8
80	9×14×12	20	4 000 (3 500)	26 000 40 000	20 600 31 500	40 000 74 500	465 865	220 695	1 670 4 000	185 580	1 400 3 350	1.2 1.7	7.0

3) The basic load rating comply with the ISO standard. (ISO 14728-1, 14728-2)  
 C<sub>50</sub>: the basic dynamic load rating for 50 km rated fatigue life C<sub>100</sub>: the basic dynamic load rating for 100 km rated fatigue life  
 4) High-precision grade and medium preload random-matching type are not available for JL and EL models.  
 \* Standard mounting hole of LS15 rail is for M3 bolts (Hole size: 3.5 × 6 × 4.5).  
 If you require mounting hole for M4 bolts (Hole size: 4.5 × 7.5 × 5.3), please specify when ordering.

LS-KL (Medium-load type / Short)  
LS-FL (High-load type / Standard)

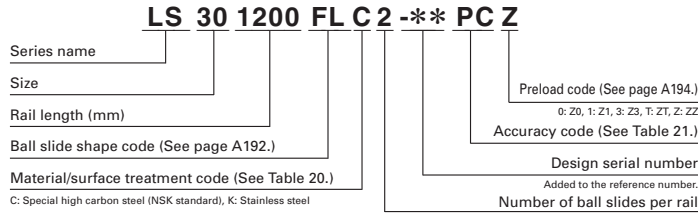

Front view of FL and KL type

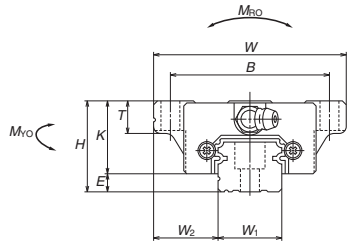

Side view of FL type

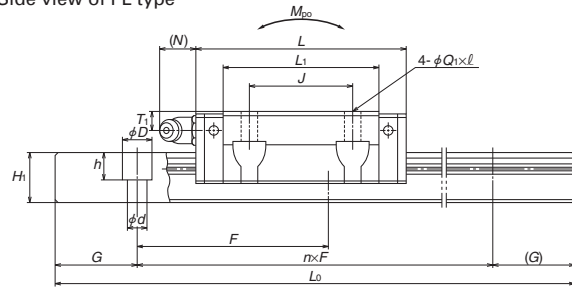

Side view of KL type

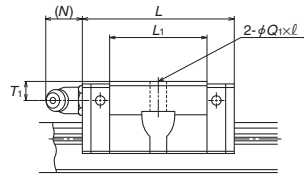

Reference number for ball slide of random-matching type

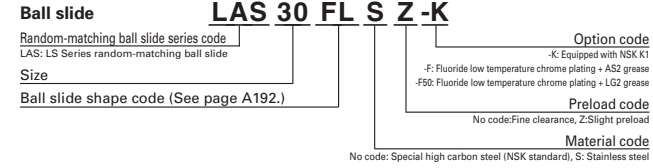

FL and KL types

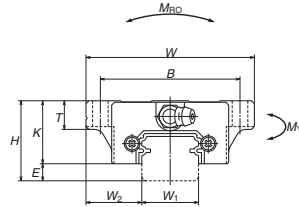

FL type

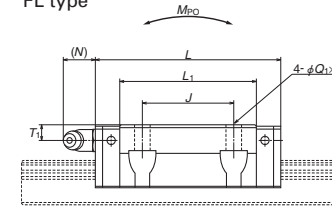

KL type

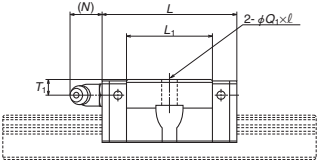

Reference number for rail of random-matching type

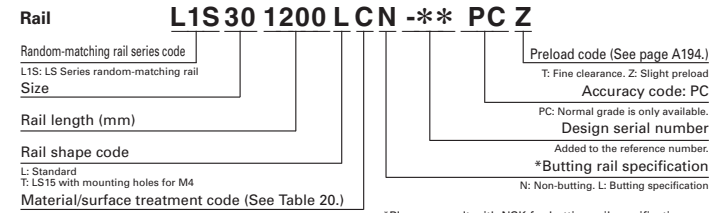

\*Please consult with NSK for butting rail specification.

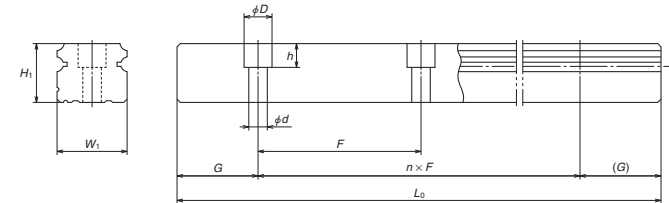

Model No.	Assembly			Ball slide											Width	Height		
	Height	E	W <sub>2</sub>	W	L	Mounting hole			L <sub>1</sub>	K	T	Grease fitting					W <sub>1</sub>	H <sub>1</sub>
						B	J	Q <sub>1</sub> × ℓ				Hole size	T <sub>1</sub>	N				
LS15KL LS15FL	24	4.6	18.5	52	40.4 56.8	41	— 26	4.5×7	23.6 40	19.4	8	φ3	6	3	15	12.5		
LS20KL LS20FL	28	6	19.5	59	47.2 65.2	49	— 32	5.5×9 (5.5×9.5)	30 48	22	10	M6×0.75	5.5	11	20	15.5		
LS25KL LS25FL	33	7	25	73	59.6 81.6	60	— 35	7×10 (7×11.5)	38 60	26	11 (12)	M6×0.75	7	11	23	18		
LS30KL LS30FL	42	9	31	90	67.4 96.4	72	— 40	9×12 (9×14.5)	42 71	33	11 (15)	M6×0.75	8	11	28	23		
LS35KL LS35FL	48	10.5	33	100	77 108	82	— 50	9×13 (9×14.5)	49 80	37.5	12 (15)	M6×0.75	8.5	11	34	27.5		

Notes: 1) The external appearance of stainless steel ball slides differs from those of carbon steel ball slides.  
 2) Parenthesized dimensions are for items made of stainless steel.

Rail		Basic load rating										Weight	
Pitch	Mounting bolt hole	G	Max. length L <sub>max</sub> (mm) for stainless	<sup>3</sup> Dynamic		Static C <sub>0</sub>	Static M <sub>RO</sub>	Static moment (N-m)				Ball slide (kg)	Rail (kg/m)
				[50km]	[100km]			M <sub>PO</sub>		M <sub>YO</sub>			
				F	d × D × h	(reference)	C <sub>50</sub> (N)	C <sub>100</sub> (N)	(N)	M <sub>RO</sub>	One slide	Two slides	One slide
60	*3.5×6×4.5 4.5×7.5×5.3	20	2 000 8 350 (1 700)	5 400 3 400 (3 500)	4 300 6 600 (3 500)	9 100 16 900 (8 450)	45.5 84.5 (91.5)	24.5 77 (47.5)	196 470 (330)	20.5 64.5 (39)	165 395 (279)	0.17 0.26 (0.24)	1.4
60	6×9.5×8.5	20	3 960 (3 500)	7 900 11 700 (3 500)	6 250 9 250 (3 500)	13 400 23 500 (160)	91.5 133 (75.5)	46.5 75.5 (111)	330 755 (630)	39 111 (63)	279 630 (330)	0.24 0.35 (0.24)	2.3
60	7×11×9	20	3 960 (3 500)	12 700 18 800 (3 500)	10 100 14 900 (3 500)	20 800 36 500 (286)	164 258 (164)	91 258 (164)	655 1 470 (1 080)	76 217 (156)	550 1 230 (905)	0.44 0.66 (0.76)	3.1
80	7×11×9	20	4 000 (3 500)	18 700 28 800 (3 500)	14 800 22 900 (3 500)	29 600 55 000 (435)	282 520 (365)	139 435 (365)	1 080 2 220 (1 670)	116 365 (220)	905 2 220 (1 400)	0.76 1.2 (1.2)	4.8
80	9×14×12	20	4 000 (3 500)	26 000 40 000 (3 500)	20 600 31 500 (3 500)	40 000 74 500 (865)	465 865 (695)	220 695 (400)	1 670 4 000 (580)	185 580 (335)	1 400 3 350 (1 700)	1.2 1.7 (1.7)	7

3) The basic load rating comply with the ISO standard. (ISO 14728-1, 14728-2)  
 C<sub>50</sub>: the basic dynamic load rating for 50 km rated fatigue life C<sub>100</sub>: the basic dynamic load rating for 100 km rated fatigue life  
 4) High-precision grade and medium preload random-matching type are not available for KL and FL models.  
 \* Standard mounting hole of LS15 rail is for M3 bolts (Hole size: 3.5 × 6 × 4.5).  
 If you require mounting hole for M4 bolts (Hole size: 4.5 × 7.5 × 5.3), please specify when ordering.